



Contents

Section	Title	Page
	Introduction	1
	Contact	2
Wiring plans	System wiring notes	3
	Sundial S Plan	4 - 5
	Sundial S Plan Plus	6 - 7
	Sundial Y Plan	8 - 9
	Sundial C Plan	10 - 11
	Sundial C Plan Plus	12
	Sundial W Plan	13
	Sundial U Plan	14
	Training	15
	Boiler wiring	16
	Programmer wiring	17
	Valve wiring	18
	Sundial RF ² wiring	19
	Smartfit	20 - 21
	Frost thermostats	22
	Wiring centre	23
Fault finding	Wired Sundial Y Plan	24 - 25
	Wired Sundial S Plan and S Plan Plus	26 - 27
	Wired Sundial C Plan	28 - 29
	Wired Sundial W Plan	30 - 31
Product selection	Energy saving	32 - 33
	Product selection	34 - 37
Further information	Website	38
	Training	39

Introduction

Domestic energy consumption

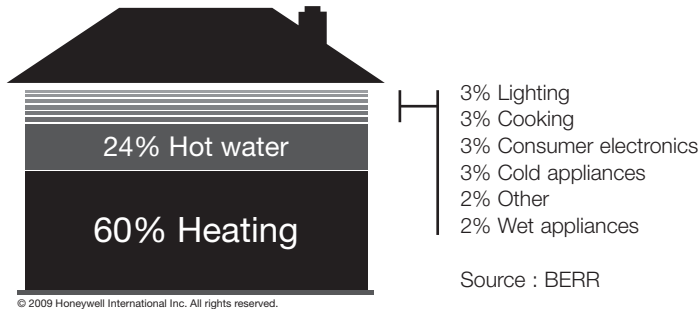

A huge amount of energy is used to heat homes. Much of it is either wasted or used inefficiently. Heating controls help to reduce waste reduce demand and use fuel more sparingly.

Honeywell has been manufacturing heating controls for over 100 years and is the UK leader for quality, efficiency and reliability.

This book contains wiring advice to assist with installing Honeywell heating controls in a variety of systems. Always try to upgrade a system to the best efficiency. This would normally be a fully pumped system with a high efficiency boiler using S, Y or S Plan Plus controls.

All wiring should be carried out by a competent installer or electrician.

These wiring diagrams are for guidance only and at the time of printing represent the latest information available to us from other manufacturers. Honeywell reserve the right at any time and without notice to change any product, specification or any other information contained in this publication and cannot accept any responsibility for loss or damage arising out of any errors that may inadvertently be contained herein.

Whilst Honeywell takes all reasonably practical steps to design and manufacture its products to comply with the requirements of the Health and Safety at Work Act 1974, all products must be properly used and purchasers are reminded that their obligations under the Act are to ensure that the installation and operation of such products at a place of work should be safe and without risk to them.

Contact

Sales Enquiries

Tel: 01344 656172

Email: insidesales@honeywell.com

Installer Training

Tel: 01344 656352

Email: installer.training@honeywell.com

Web: www.honeywelluk.com (see Training page under Support Services menu)

Product Literature

Tel: 0800 521121

Email: literature@honeywell.com

Web: www.honeywelluk.com (see Downloads menu)

Technical Support

Tel: 08457 678999

Email: technical.support@honeywell.com

Web: www.honeywelluk.com (see FAQ section)

To help in dealing with your technical support enquiry efficiently (whether via phone or email) please supply the **part code, product name and date code**. Please only call our technical support number if you are an installer. End user support literature such as user guides and brochures is available for download on our website.

All phone lines are open Monday to Thursday 9am to 5pm and Friday 9am to 4pm. Closed all bank holidays.

System wiring notes

The Sundial Plan diagrams in this guide are designed for ease of wiring to a 10 way junction box (Honeywell part number 42002116-001). Where three plans are illustrated there is one for wired, wireless and wireless enabled controls.

Connect the controls, pump, boiler and 230 Volt fused supply to the junction box terminals indicated by the arrows in the diagrams next to each control, other electrical device or circuit. These diagrams should be read in conjunction with product installation instructions.

A list of boilers can be found on page 16. Boilers with built in programmers must be wired in accordance with the manufacturers instructions.



10 way junction box
42002116-001

ALL WIRING MUST BE IN ACCORDANCE WITH IEE & BUILDING REGULATIONS AND IN SOME CASES, NOTIFIABLE TO BUILDING CONTROL.

A list of programmers can be found on page 17. The room thermostat and programmer are for use with fixed wiring only; the cylinder thermostat may be used with fixed wiring or flexible cable; the motorised valves are supplied fitted with a one metre length of heat resistant cable.

A switch (having contact separation of at least 3mm in all poles) must be incorporated in the fixed wiring as a means of disconnecting the mains supply.

The heating system must be appropriately fused for gas appliances. The diagrams refer only to 3 amp fuses for gas appliances throughout. Use a 5 amp fuse for oil where appropriate. The T6360B room thermostat, L641A cylinder thermostat and Honeywell range of programmers are Class II (double insulated) devices. Earth terminals, where provided, are for earth parking purposes only. All earth conductors inside the programmer and room thermostat must be appropriately sleeved. The zone valves are Class I devices and must be connected to a suitable earth.

Sundial S Plan

If using a 6 wire 28mm or 1" BSP V4043H on either circuit, the white wire is not needed and must be made electrically safe.

Fully Pumped System only

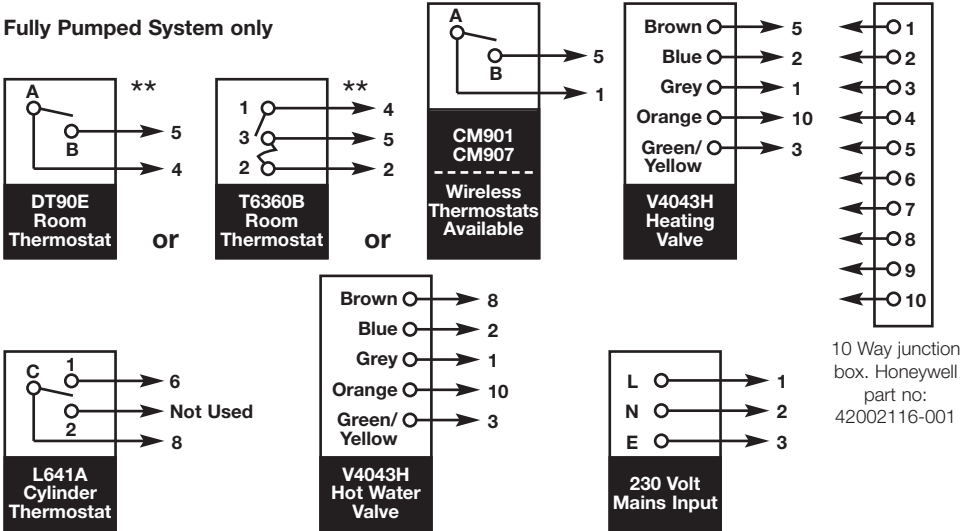

For list of central heating boilers to attach to this circuit - see page 16.

For list of programmers to attach to this circuit - see page 17.

When circuit is wired as above: Completed wiring will be as line drawing below.

Wired

NOTE:

- It is recommended that either the 10 way junction box or Sundial Wiring Centre should be used to ensure first time, fault free wiring.
- If using the V4043H1080 (1" BSP) or V4043H1106 (28mm), the white wire must be electrically isolated.
- For wiring other room thermostats see above**.

Pump overrun

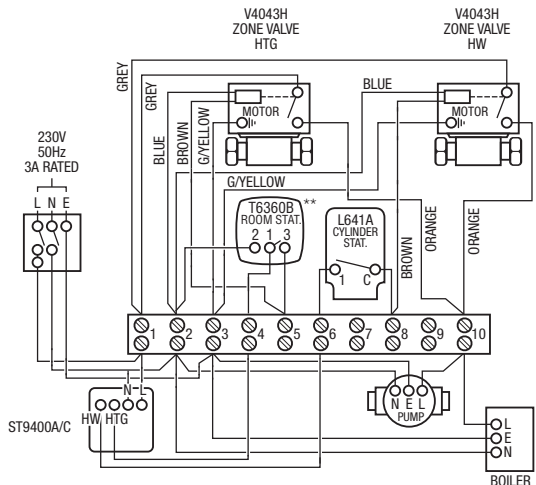
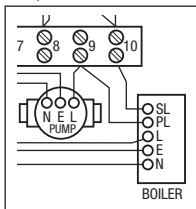

For Frost Protection information - see page 22

Sundial S Plan

Wireless room thermostat

NOTE:

1. It is recommended that either the 10 way junction box or Sundial Wiring Centre should be used to ensure first time, fault free wiring.
2. If using the V4043H1080 (1" BSP) or V4043H1106 (28mm), the white wire must be electrically isolated.
3. The same terminal numbers are used on the receiver for both the DT92E and Y6630D Wireless Room Thermostats.

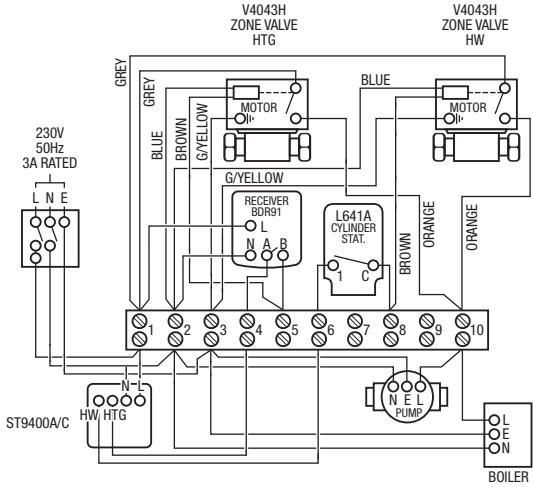
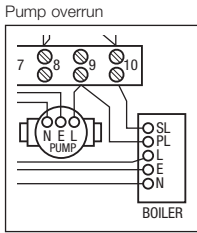

For Frost Protection information - see page 22

Wireless enabled room thermostat (Sundial RF² Pack 2)

NOTE:

1. It is recommended that the 10 way junction box should be used to ensure first time, fault free wiring.
2. If using the V4043H1080 (1" BSP) or V4043H1106 (28mm), the white wire must be electrically isolated.
3. If replacing an old wired thermostat remove cabling and add a link between terminals 4 and 5 as shown.

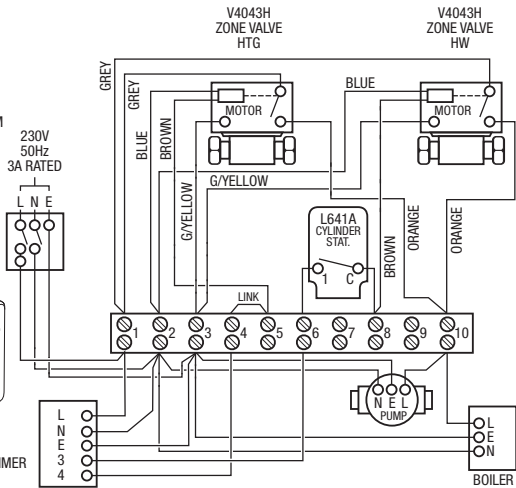
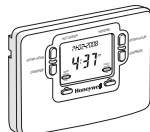
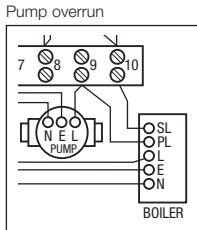

For Frost Protection information - see page 22

Sundial S Plan Plus

If using a 6 wire 28mm or 1" BSP V4043H on either circuit, the white wire is not needed and must be made electrically safe.

Fully Pumped System only

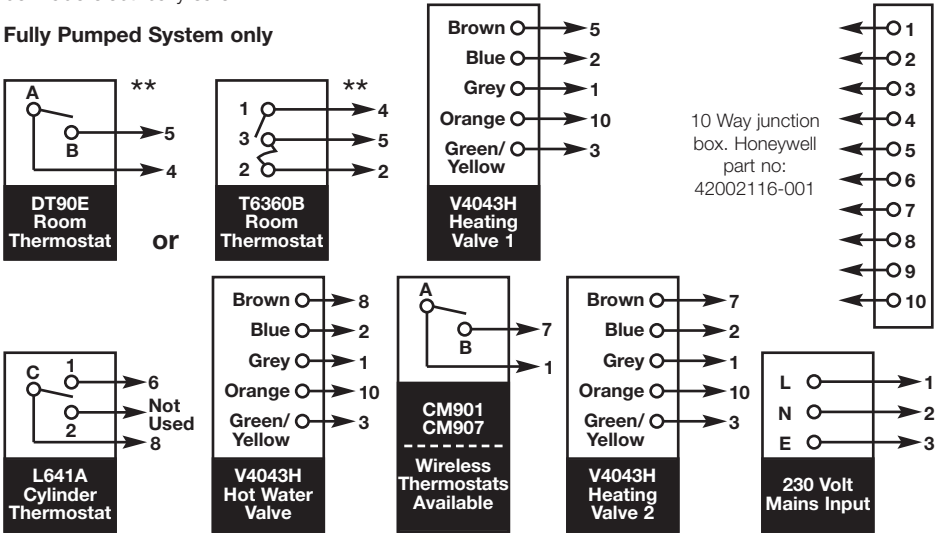

For list of central heating boilers to attach to this circuit - see page 16.

For list of programmers to attach to this circuit - see page 17.

When circuit is wired as above: Completed wiring will be as line drawing below.

Wired

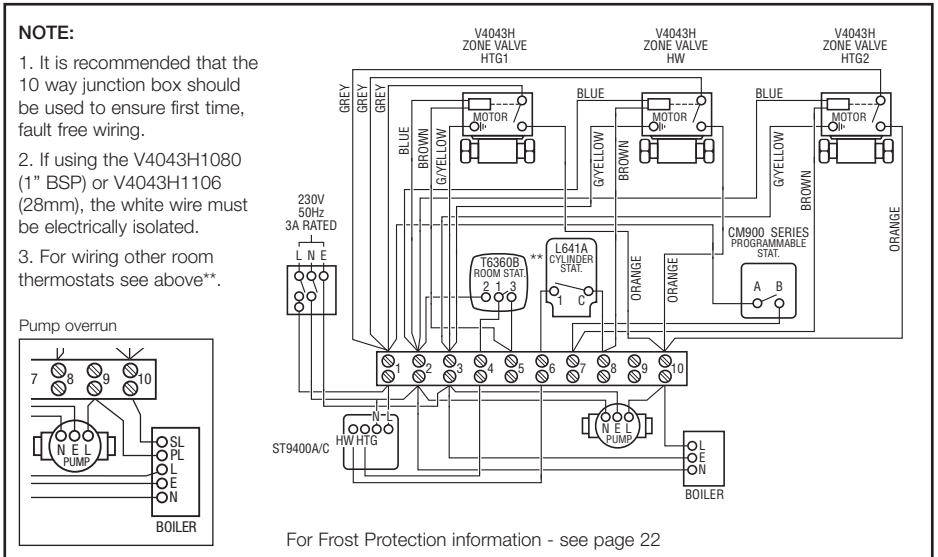

Sundial S Plan Plus

Wireless room thermostat

NOTE:

1. It is recommended that the 10 way junction box should be used to ensure first time, fault free wiring.
2. If using the V4043H1080 (1" BSP) or V4043H1106 (28mm), the white wire must be electrically isolated.
3. The same terminal numbers are used on the receiver for both the DT92E and Y6630D Wireless Room Thermostats.



DT92E
WIRELESS ROOM
THERMOSTAT

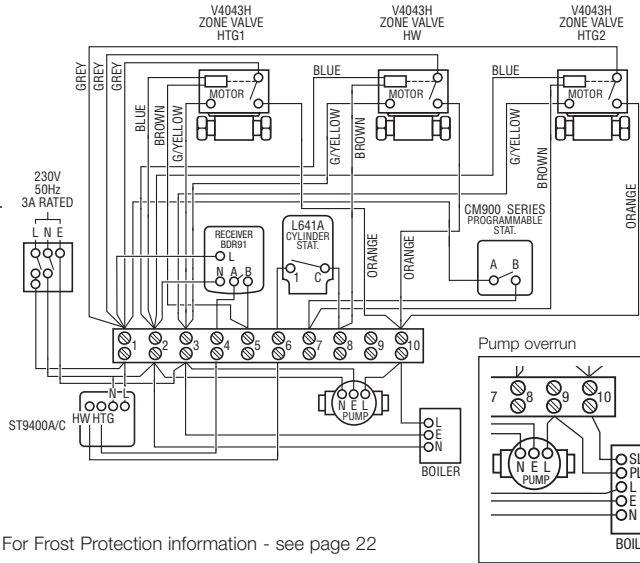

Sundial Y Plan

Fully Pumped System only

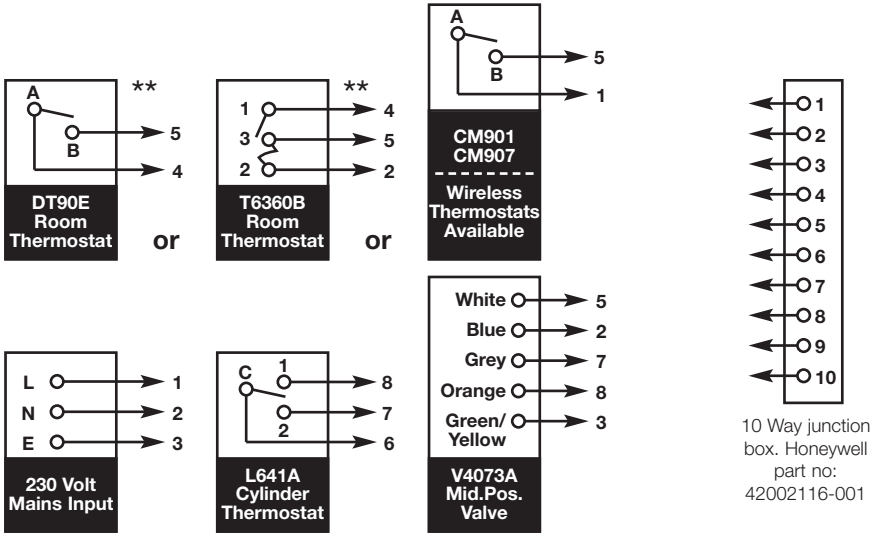

For list of central heating boilers to attach to this circuit - see page 16.
 For list of programmers to attach to this circuit - see page 17.

When circuit is wired as above: Completed wiring will be as line drawing below.

Wired

NOTE:

1. It is recommended that the 10 way junction box should be used to ensure first time, fault free wiring.
2. For wiring other room thermostats see above**.

Pump overrun

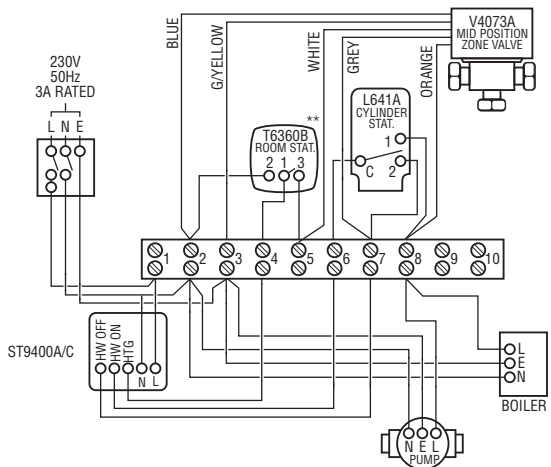
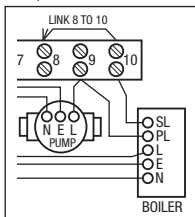

For Frost Protection information - see page 22

Sundial Y Plan

Wireless room thermostat

NOTE:

1. It is recommended that the 10 way junction box should be used to ensure first time, fault free wiring.
2. The same terminal numbers are used on the receiver for both the DT92E and Y6630D Wireless Room Thermostats.

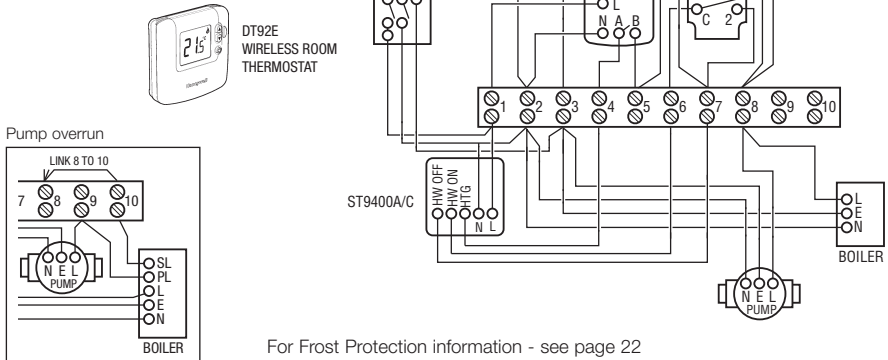

For Frost Protection information - see page 22

Wireless enabled room thermostat (Sundial RF² Pack 2)

NOTE:

- It is recommended that the 10 way junction box should be used to ensure first time, fault free wiring.

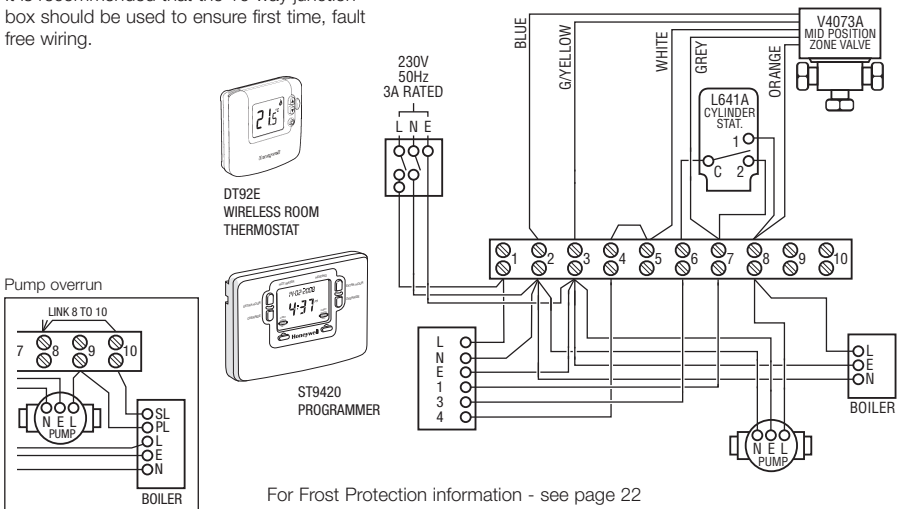

For Frost Protection information - see page 22

Sundial C Plan

Gravity Hot Water, Pumped Central Heating

Link terminals 5 - 9 in the 10 way junction box.

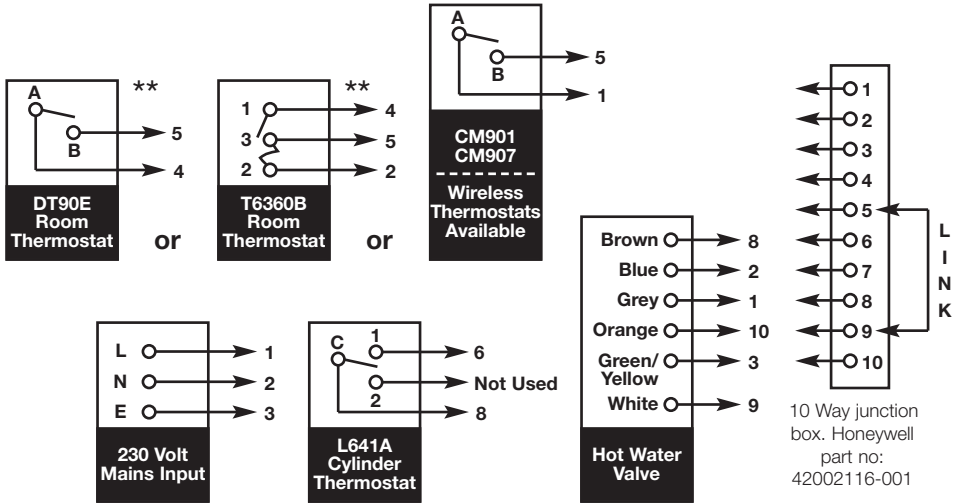

For list of central heating boilers to attach to this circuit - see page 16.

For list of programmers to attach to this circuit - see page 17.

When circuit is wired as above: Completed wiring will be as line drawing below.

Wired

NOTE:

1. It is recommended that the 10 way junction box should be used to ensure first time, fault free wiring.
2. For wiring other room thermostats see above**.

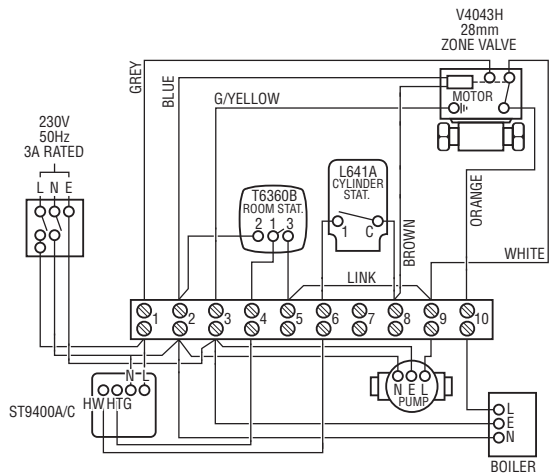

For Frost Protection information - see page 22

Sundial C Plan

Wireless room thermostat

NOTE:

1. It is recommended that the 10 way junction box should be used to ensure first time, fault free wiring.
2. The same terminal numbers are used on the receiver for both the DT92E and Y6630D wireless room thermostats.

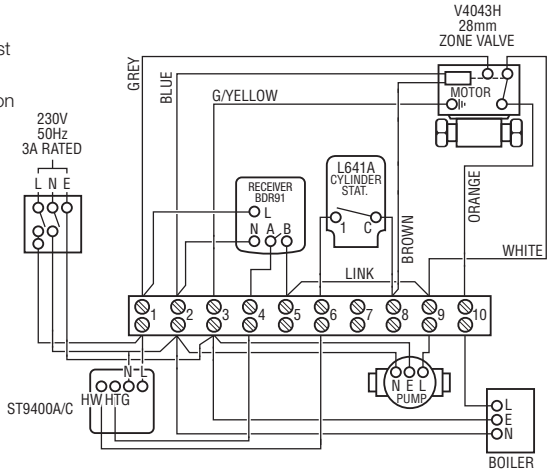

For Frost Protection information - see page 22

Wireless enabled room thermostat (Sundial RF² Pack 2)

NOTE:

1. It is recommended that the 10 way junction box should be used to ensure first time, fault free wiring.
2. The same terminal numbers are used on the receiver for both the DT92E and Y6630D Wireless Room Thermostats.

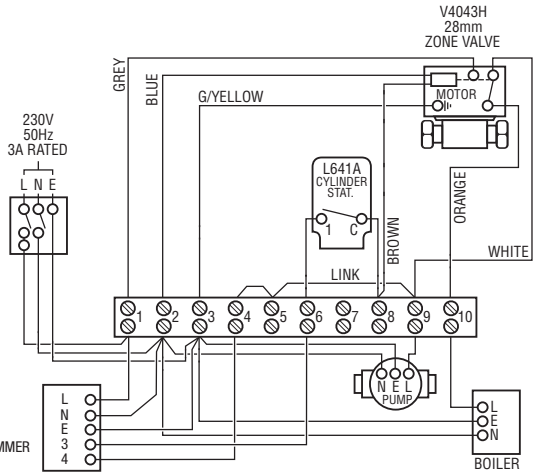

For Frost Protection information - see page 22

Sundial C Plan Plus

Gravity Hot Water, Pumped Central Heating

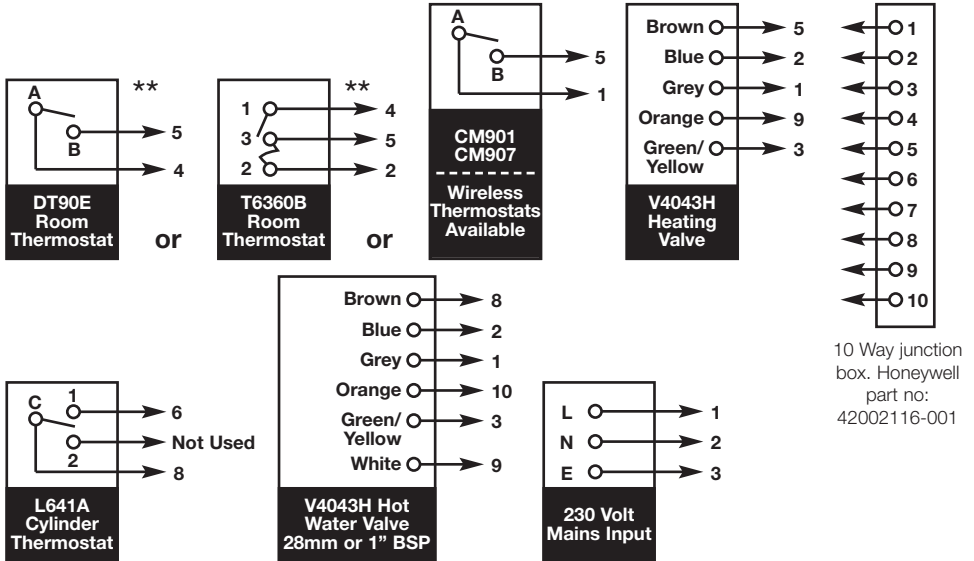

For list of central heating boilers to attach to this circuit - see page 16.
 For list of programmers to attach to this circuit - see page 17.

When circuit is wired as above: Completed wiring will be as line drawing below.

Wired

NOTE:

1. It is recommended that the 10 way junction box should be used to ensure first time, fault free wiring.
2. For wiring other room thermostats see above**.

For Frost Protection information - see page 22

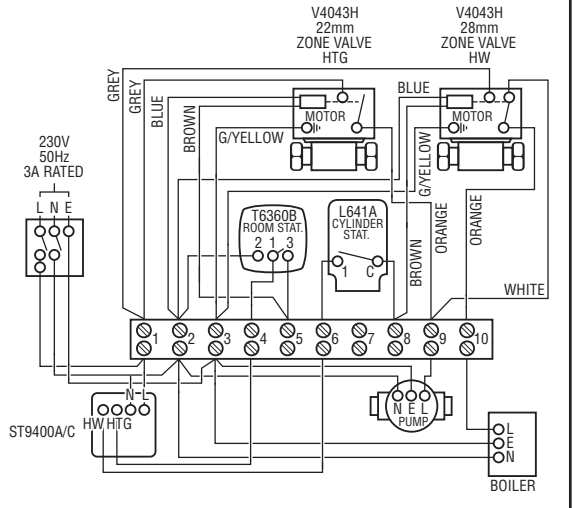

Sundial W Plan

Fully Pumped System only (hot water priority)

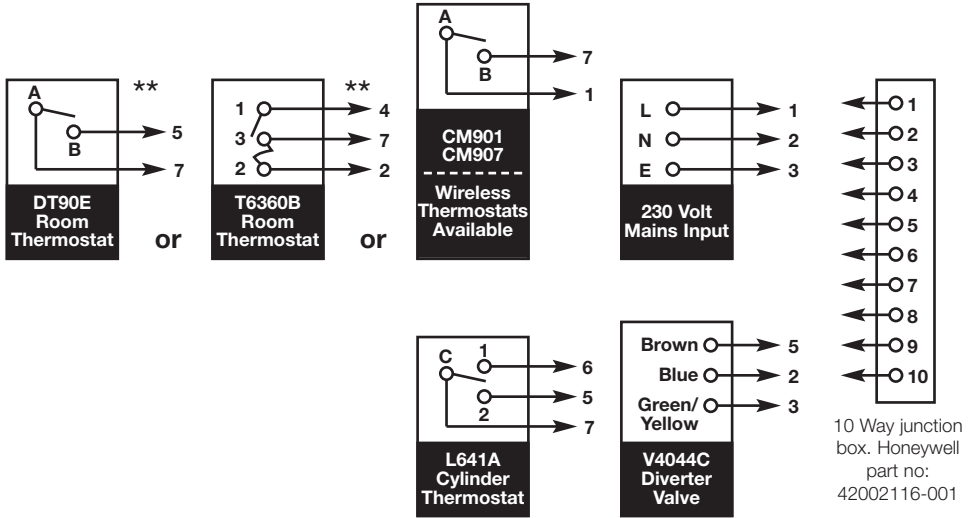

For list of central heating boilers to attach to this circuit - see page 16.
 For list of programmers to attach to this circuit - see page 17.

When circuit is wired as above: Completed wiring will be as line drawing below.

Wired

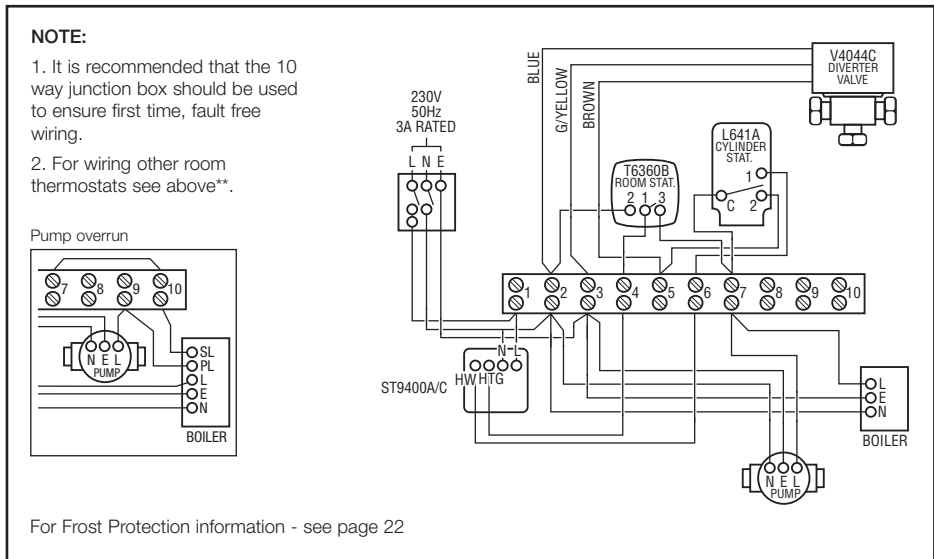

Sundial U Plan

Typical Multi-Manifold Schematic Wiring Diagram Using M100 - BG Actuators

Wiring plans

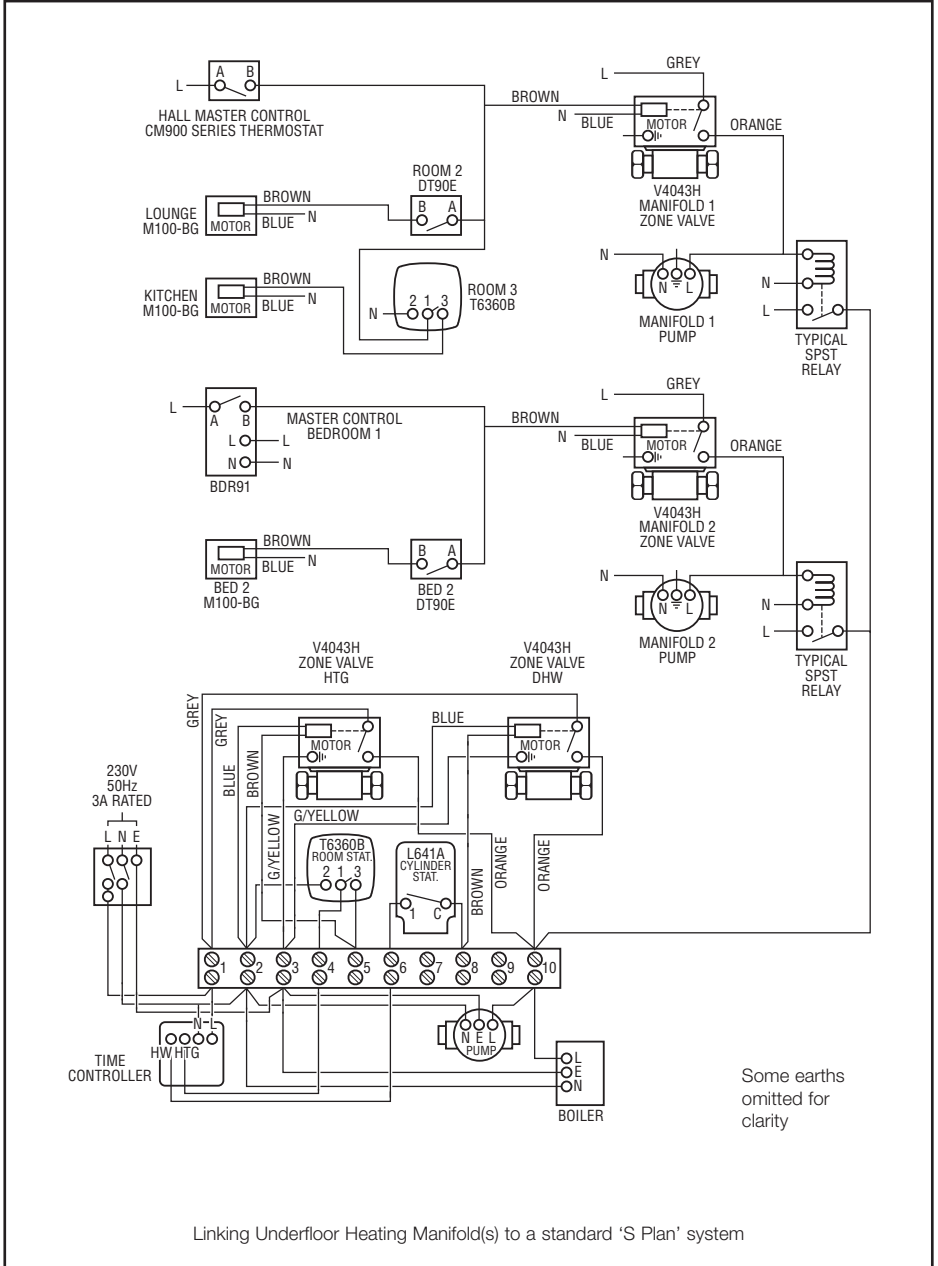

Training

Installer Training courses

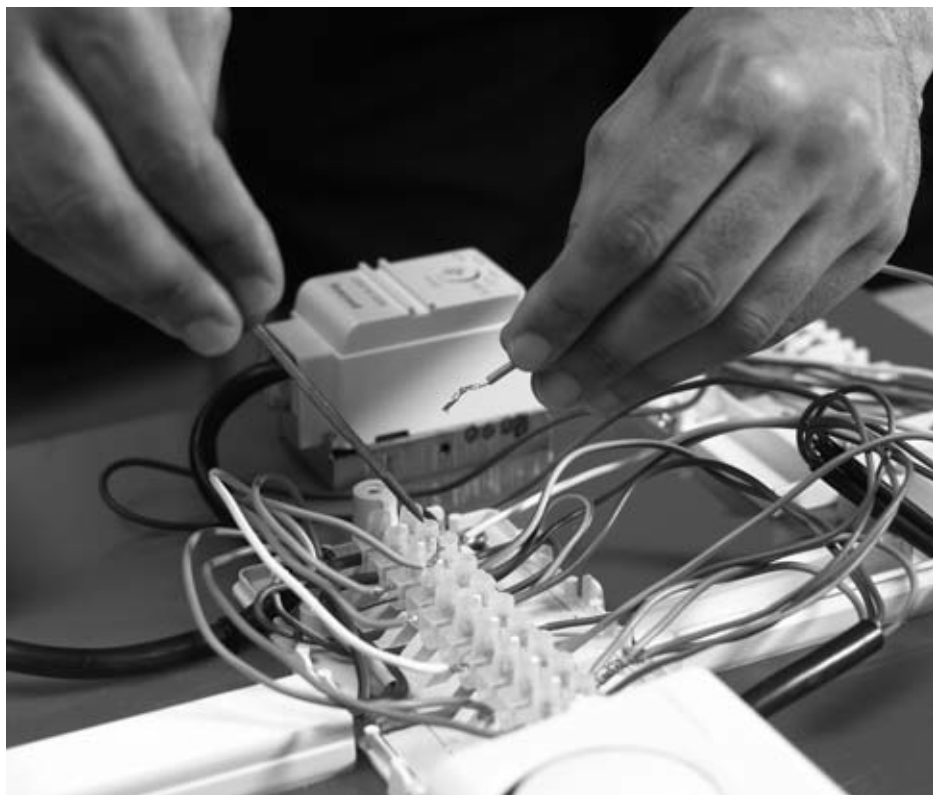

Expand your knowledge of heating and water controls with expert training on our one day Installer courses, all for £30.

- Hands on wiring
- Fault finding
- Learn about the latest products
- Energy conservation
- Part L Building Regulations
- Wireless controls
- Zoning
- Smartfit
- Sundial plans
- Frost protection
- Control selection

Available across UK and Ireland.

Tel: 01344 656352

Email: installer.training@honeywell.com

Web: www.honeywelluk.com

Boiler Wiring

Terminal Block	BOILER				PUMP				
S Plan	9	10	3	2	1	9	10	2	3
S Plan Plus	9	10	3	2	1	9	10	2	3
Y Plan	9	8	3	2	1	9	8	2	3
C Plan	9	10	3	2	1	9	10	2	3
C Plan Plus	9	10	3	2	1	9	10	2	3
W Plan	9	7	3	2	1	9	7	2	3
REGULAR BOILER	↑	↑	↑	↑	↑	↑	↑	↑	↑
Basic Boiler		L	E	N		L	N	E	
Baxi 45/4 & 57/4	SL	E	N			L	N	E	
Baxi Bermuda	SL	E	N			L	N	E	
Baxi Inset 2-50/4e	SL	E	N			L	N	E	
Baxi Bermuda Inset 3	SL	E	N			L	N	E	
Baxi Boston 2	SL	E	N			L	N	E	
Baxi Solo 2 RS	PL	SL	E	N		L	N	E	
Ferrolli Roma 55FF	4	2	E	N	L	L	N	E	
Ferrolli Sigma	PL	Sw	E	N	L	L	N	E	
Glow-Worm Energy 60	PL	SL	E	N	L	L	N	E	
Glow-Worm Micron FF		Ls	E	N	L	L	N	E	
Glow-Worm Ultimate 60FF	P	SL	E	N	L				
Glow-Worm Ultimate 70FF	7	SL	E	N	L	7	8	E	
Grant Euroflame 50/70		1	3	2		L	N	E	
Grant Multipass 50/70		1	4	2		L	N	E	
Ideal Istor		L2	E	N	L3	L	N	E	
Potterton Kingfisher 50-100	PL	Sw	E	N	L	L	N	E	
Potterton Osprey 2 CFL	PL	SL	E	N	L	L	N	E	
Potterton Prima C	PL	Sw	E	N	L	L	N	E	
Potterton Profile 40-80eL	PL	Sw	E	N	L	L	N	E	
SYSTEM BOILERS	↑	↑	↑	↑	↑	↑	↑	↑	↑
Baxi 100HE	PF	SL	E	N		L	N	E	
Baxi Barcelona	PF	SL	E	N	L	L	N	E	
Ideal Icos		L2	E	N	L3	L	N	E	
Ideal Isar		L2	E	N	L3	L	N	E	
Keston Celsius		SL	E	N	PL				
Potterton Promax	PF	SL	E	N	L	L	N	E	
Worcester Greenstar		Lr	E	N	L				
OIL BOILERS	↑	↑	↑	↑	↑	↑	↑	↑	↑
Boulter Bonus		L	E	N		L	N	E	
Esse 60, 80, 100		10	E	3		L	N	E	
Grant Multi Pass 50/70		1	4	2		L	N	E	
Potterton Statesman		L	E	N		L	N	E	
Rayburn 368K Range		Bk	E	N	L	L	N	E	
Rayburn Heatranger	PL	Sw	E	N	L	L	N	E	

Terminal Block	COMBI			CM901 CM907 STAT			
S Plan			3	2	1	1	5
S Plan Plus			3	2	1	1	7
Y Plan			3	2	1	1	5
W Plan			3	2	1	1	7
COMBI BOILERS	↑	↑	↑	↑	↑	↑	
Alpha CB24/28			E	N	L	1	2
Baxi Combi 130HE			E	N	L	3	4
Baxi Combi 80Eco			E	N	L	1	2
Baxi Combi 80 Maxflue			E	N	L	1	2
Baxi Combi Instant			E	N	L	1	2
Boulter Camray 5 (Oil)			E	N	L	4	5
Ferrolli Arena			E	N	L	1	2
Ferrolli Domina			E	N	L	4	5
Ferrolli Optima			E	N	L	4	5
Glow-Worm Compact			E	N	L	1	2
Grant Combi MK11			4	2	1	13	14
Ideal C80/C95FF			E	N	L	Bk	R
Ideal Response			E	N	L	R1	R2
Potterton Combi 80			E	N	L	3	4
Potterton Flowsure+			E	N	L	3	4
Potterton Performa			E	N	L	1	2
Potterton Puma			E	2	1	3	4
Range Powermax			E	N	L	10	9
Valliant Turbomax			E	N	L	3	4
Worcester CDI			E	N	L	Ls	Lr
Worcester Greenstar			E	N	L	Ls	Lr
Worcester Highflow			E	N	L		

Terminal Block	BOILER				PUMP				
S Plan	9	10	3	2	1	9	10	2	3
S Plan Plus	9	10	3	2	1	9	10	2	3
Y Plan	9	8	3	2	1	9	8	2	3
C Plan	9	10	3	2	1	9	10	2	3
C Plan plus	9	10	3	2	1	9	10	2	3
W Plan	9	7	3	2	1	9	7	2	3
CONDENSING BOILER	↑	↑	↑	↑	↑	↑	↑	↑	↑
Baxi 35/60 & 60/100		SL	E	N	L				
Baxi Solo 3 PFL	PL	SL	E	N	L	L	N	E	
Boulter Bonus (Oil)			E	N	L				
Ferrolli Tempra		SL	E	N	L				
Glow-Worm Compact 60		Ls	E	N	Lp				
Glow-Worm HXI		2	E	N	L				
Grant Multipass (Oil)		1	4	2					
Ideal Icos		L2	E	N	L3				
Outdoor Modules 50/70	1		4	3	2				
Valliant Ecotec		4	E	N	L				
Valliant Thermocompact		4	E	N	L				

Programmer Wiring

Connect onto terminal block numbers →

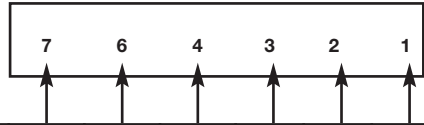

Programmer Interchange	HW OFF	HW ON	CH ON	E	N	L
Honeywell ST9400, ST9420, ST9500	1	3	4	E	N	L
Honeywell ST6450, ST6400, ST6300	1	3	4	E	N	L
Honeywell ST6200		3	4	E	N	L
Honeywell ST699B, ST799A, (Link L-5-8)	7	6	3		N	L
Honeywell ST7100	7	8	5	E	N	L
ACL Drayton LS522, LS722, LP112, LP241	1	3	4	E	N	L
Danfoss CP15, CP75, FP15, FP75, MP15, MP75, CP715, FP715	1	3	4	E	N	L
Glow-Worm Mastermind		3	4		N	L
Horstmann C21, C27, C121 & C127	1	3	4	E	N	L
Landis RWB2, RWB9, RWB20, 40, 102, 270	1	3	4	E	N	L
Landis RWB20, RWB200	1	3	4	E	N	L
Landis RWB252, Microgyr	1	3	4	E	N	L
Potterton Miniminder	1	3	4	E	N	L
Potterton EP2000/3000/6000 EP2001/3001 (Link L-5)	1	3	4	E	N	L
Sunvic Select 207	1	3	4	E	N	L
Horstmann 425, 525, 527, H21, H27, H121, Tiara, (Link L-2-5)	3	1	4	E	N	L
Randall 922, 972, (Link L-2-5)	1	3	6		N	L
Randall 4033 (Link 1-6)	5	4	2	E	7	6
Randall 102, 102E, 102E5, 102E7, (Link 3-6)		1	2	E	5	6
Randall 701, 702, (Link L-6-5)		4	2	E	N	L
Sangamo M5, (Link 1-6)		1	8	E	N	L
Sangamo Form 1, (Link 3-6)		1	8	E	N	L
Switchmaster Symphony	3	1	4		N	L
Switchmaster 400, 600, (No connection to terminal 4 on 600)		3	1		N	L
Switchmaster 805, 900, 905, 9001	4	3	1		N	L
Sunvic SP50, SP100, (Link L-3)	1	2	5	E	N	L
Sunvic ET1451, (Link 2-3-6)	8	7	4	E	1	2
Sunvic DHP2201	8	6	3	E	1	2
Towerchron FP, (Link 1-5 / 4-7-9)	8	6	10		N	L
Towerchron MP, (Link 1-4 / 6-11)		6	10		N	L
Danfoss Randall 3020P, 3060		4	2	E	7	6
Danfoss Randall SET2, SET2E, SET3EM, FP975, SET5, (Link L-2-5)	3	1	4	E	N	L
Grasslin Towerchron DP72, QE2	1	3	4		N	L
Myson Microtimer, (Link L-5-8)	7	6	3		N	L
Sunvic SP50, SP100, (Link L-3)	1	3	4		N	L

Valve Wiring

Replacement Wiring Guide for the old V4073A1005 to all new V4073A models

The old valve had 6 wires and a relay plugged into one end.

When replacing this old model with the newer model, wire the new valve colour for colour apart from the **Brown** wire which is missing from the new valve.

ON SINGLE CHANNEL TIME SWITCHES

Omit **Brown** wire and reverse C & 1 on the cylinder thermostat.

ON DOUBLE CHANNEL PROGRAMMERS i.e. separate switching outputs for Heating and Hot Water circuits.

Omit **Brown** wire and reverse C & 1 on the cylinder thermostat.

- For programmers capable of selecting heating only: **Run extra cable from the Grey wire on the valve to the HOT WATER OFF terminal on the programmer.**
- For programmers NOT capable of selecting heating only: **This extra cable is NOT required and MUST NOT be included.**

EXCEPT:

1. ON RANDALL 4033 PROGRAMMER

Remove wire that connects to cylinder thermostat 1 at JUNCTION BOX end and re-connect to **Orange** wire connection of mid-position valve. Disconnect wire at Terminal 1 on programmer, isolate and make safe. Add link in programmer back plate between Terminals 1 and 6.

NB. If the Randall 4033 has been used as a junction box, any wires going into terminal 1 should be removed and re-connected into a spare terminal connector (not supplied by Honeywell).

2. ON SANGAMO 410 FORM 1 PROGRAMMER

Follow instructions for Randall 4033, except on programmer base plate, disconnect wire on Terminal 3 and add link between 3 and 6 on baseplate of Programmer.

MOTORISED VALVE INTERCHANGEABILITY GUIDE

MODEL	No.	E	N	S/L	HW ON	CH ON	HW OFF
HONEYWELL	V4073A	GY	BL	OR		WH	GR
ACL	679H340	GY	BL	OR		WH	GR
ACL	679B340	GY	BL	OR		WH	GR
Danfoss/Randall	DVM-3M	GY	BL	OR		WH	GR
Danfoss/Randall	HSA3	GY	BL	OR		BR	GR
Drayton Flowshare	2	GY	BL	OR		WH	GR
Grasslin/Tower	MP 22C	GY	BL	OR		WH	GR
Landis & Gyr	MAV322	GY	BL	OR		WH	GR
Pegler/Sunvic	SD2701	GY	BL	OR		WH	GR
Pegler/Sunvic	SDV2211	GY	BL	OR		WH	GR
Pegler/Sunvic	SD1701	GY	BL	OR		BR	GR
Potterton/Myson	PMV3	GY	BL	OR		BR	GR
Potterton/Myson	MSV322		BL	OR		WH	GR
Sopac	ZV20-EB	GY	BL	RE		WH	GR
Switchmaster	MIDI	GY	BL	RE	OR	YE	WH
Danfoss Heatshare		GY	BL	RE	OR	YE	WH

ADD LINK

MODEL	No.	E	N	S/L	Motor	PL
HONEYWELL	V4043H	GY	BL	OR	BR	GR
ACL	679H308-30L1	GY	BL	OR	BR	GR
ACL	679B308-30L1	GY	BL	BK	BR	WH
Danfoss/Randall	DVM-2C	GY	BL	OR	BR	GR
Danfoss/Randall	HP2A		BL	OR	BR	GR
Drayton		GY	BL	OR	BR	GR
Landis & Gyr	ZAV222	GY	BL	OR	BR	GR
Pegler/Sunvic	SZV 1212		BL	OR	BR	GR
Potterton/Myson	PMV43	GY	BL	OR	BR	GR
Randall	HPA2	GY	BL	OR	BR	GR
Sopac	ZV20-2-EB	GY	BL	RE	WH	GR
Switchmaster	Auto Z	GY	BL	OR	BR	GR
Tower/Grasslin	MV2-22C	GY	BL	OR	BR	GR
Sunvic V*203		GY	BL	OR	YE	
(White wire - make electrically safe)						
Connect Grey wire on V4043H to permanent live.						

GY = Green/Yellow BL = Blue OR = Orange
 YE = Yellow BR = Brown WH = White
 BK = Black RE = Red GR = Grey

Sundial RF² Wiring

Simply replace the programmer and the thermostat works automatically

ST9420 fits on the following programmer backplates directly:

Supplier	Programmer
ACL-Drayton	SM2
ACL-Drayton	LP112
ACL-Drayton	LP241
ACL-Drayton	LP522
ACL-Drayton	LP722
ACL-Drayton	LP241Si
ACL-Drayton	LP522Si
ACL-Drayton	LP722Si
ACL-Drayton	Tempus 3
ACL-Drayton	Tempus 4
ACL-Drayton	Tempus 6
ACL-Drayton	Tempus 7
ACL-Drayton	LS241
ACL-Drayton	LS522
ACL-Drayton	LS722
Barlo	EPR1
Boss Therm	RPF7
Boss Therm	RP24
British Gas	EMP1
British Gas	EMP2
British Gas	UP1
Danfoss	CP15
Danfoss	CP75
Danfoss	CP715
Danfoss	CP715Si
Danfoss	FP15
Danfoss	FP75
Danfoss	FP715
Danfoss	FP715Si
Danfoss	MP15
Danfoss	MP75
Glowworm	Mastermind
Homexpert	THR860S
Honeywell	ST6400A
Honeywell	ST6400C
Honeywell	ST9400A
Honeywell	ST9400C
Horstmann	Centaurplus C21
Horstmann	Centaurplus C27
Horstmann	Centaurplus C121
Horstmann	Centaurplus C127

Supplier	Programmer
Iflow	Iflow PR
Landis & Gyr	RWB40
Landis & Gyr	RWB102
Landis & Gyr	RWB200
Landis & Gyr	RWB200cw
Landis & Gyr	RWB252
Landis & Gyr	RWB252cw
Landis & Gyr	RWB270
Landis & Gyr	RWB1
Landis & Gyr	RWB Mk1
Landis & Gyr	RWB2
Landis & Gyr	RWB2 Mk2
Landis & Gyr	RWB2.9
Landis & Gyr	RWB9
Landis & Gyr	RWB-XP
Landis & Staefa	RWB9
Landis & Staefa	RWB2E
Microgyr	1
Microgyr	102
Microgyr	2
Microgyr	40
Microgyr	200
Microgyr	200cw
Microgyr	252
Microgyr	252cw
Microgyr	270
Microgyr	9
Microgyr	XP
Potterton	Miniminder
Potterton	Miniminder E
Sankey	Sunline
Siemens	RWB29
Siemens	RWB270
Sunvic	Select 207
Thorn	Miniminder
Wickes	RWB2/6832
Wickes	RWB200.cw
Wickes	RWB252.cw
Wickes	RWB2E.cw
Wickes	RWB9.cw

This information is based on the backplate supplied with the original programmer.

Smartfit

Smartfit S Plan System connected for pump overrun boiler

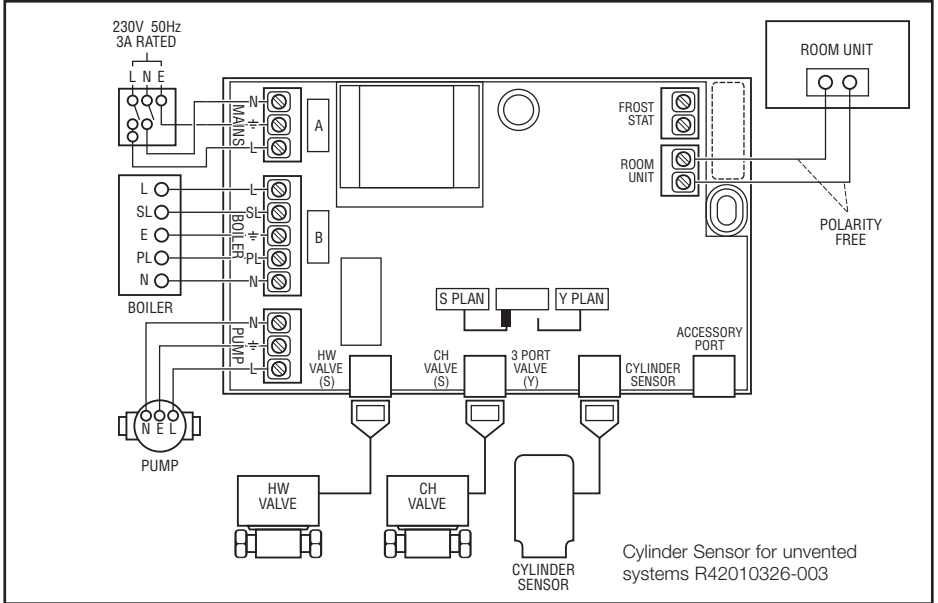

Smartfit Y Plan System connected for basic boiler

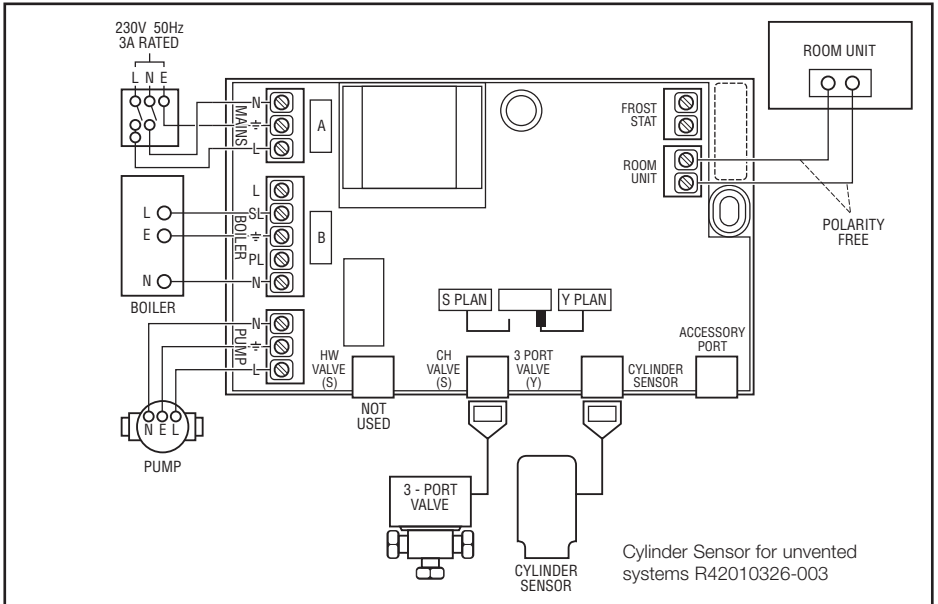

In the event of a problem, a fault code will be displayed on the Room Unit display. Before removing Base Unit cover, isolate mains.

Fault Codes

Fault Code	Description	Action
Blank display	No display	a) Switch system off then on again b) Check that power is supplied to the base unit c) Check room unit connections at base unit and room unit
F1	Room Sensor Fault	a) Replace room unit
F2	S Plan - Central heating valve open circuit Y Plan - 3 Port valve open circuit	a) Check valve connections at base unit and valve b) Check valve cable for open circuit c) Change actuator
F3	S Plan - Central heating valve short circuit Y Plan - 3 Port valve short circuit	a) Ensure valve is plugged into correct socket b) Check valve connections at base unit and valve c) Check valve cable for short circuit d) Change actuator
F4	S Plan - Central heating valve jammed Y Plan - 3 port valve jammed	a) Check actuator is fitted to the valve b) Check actuator drives valve full travel. If not, remove actuator and check actuator will drive for at least 10 seconds c) Use manual lever on actuator to free valve d) Check valve for blockage and clear
F5	S Plan - Hot water valve open circuit	a) See F2 corrective action
F5	Y Plan - Incorrect system selection switch position	a) Ensure system selection switch in base unit is set to Y Plan position*
F6	S Plan - Hot water valve short circuit	a) See F3 corrective action
F6	Y Plan - Incorrect system selection switch position	a) Ensure system selection switch in base unit is set to Y Plan position*
F7	S Plan - Hot water valve jammed	a) See F4 corrective action
F7	Y Plan - Incorrect system selection switch position	a) Ensure system selection switch in base unit is set to Y Plan position*
F8	Cylinder sensor short circuit	a) Ensure cylinder sensor is plugged into correct socket b) Change cylinder sensor
F9	Cylinder sensor open circuit	a) Ensure cylinder sensor is plugged into correct socket b) Change cylinder sensor
F10	Valve in cylinder sensor socket	a) Reconnect valve to correct socket
F11	Valve or cylinder sensor in accessory port	a) Reconnect valve or cylinder sensor to correct socket
F12	Communication fault between room unit and base unit	a) Check room unit wiring b) Switch system off then on again c) Replace room unit d) Replace base unit
F13	Configuration fault	a) Replace room unit
F14	System selection switch fault	a) Check system selection switch in base unit is set to Y or S Plan position depending on the plan you have* b) Move switch across to plan you don't want then back to correct plan* c) Replace base unit
F15	Plug in hot water socket	a) Remove plug in hot water socket and connect to correct socket
F16	Remote room unit fault	a) Check remote room unit wiring b) Replace remote room unit
F17	Outside sensor short circuit	a) Check outside sensor wiring
F18	Outside sensor open circuit	a) Check outside sensor wiring
F19 to F22	Not used in S or Y Plan systems	Not used in S or Y Plan systems
F23	No automatic time set (ATS) signal for 5 days	a) Check ATS module is attached correctly b) De-select and then re-select ATS in Installer Mode c) Refer to ATS installer guide for detailed fault finding
F24	Internal fault	a) Replace room unit

*When changing the system selection switch the power must be off.

Frost Thermostats

T4360 Frost Thermostat and L641B Pipe Thermostat

To reduce the risk of frozen pipework during severe cold weather, Frost Protection can be installed to protect either the whole central heating system or the boiler and localised pipework. These controls are designed to override the Programmer and Room Thermostat controls whether wired, wireless or wireless enabled.



If a Frost Thermostat only is to be installed to protect the whole central heating system, it must be sited where a rise and fall in heated air temperature can be detected, i.e. in a room with a radiator, and set to 12-16°C. This function is built in to programmable thermostats and Sundial RF². If the Frost Thermostat is installed outside the heated area, i.e. in a boiler room, garage or attic space, it is strongly recommended that a Pipe Thermostat be used as well to ensure that overheating of the property does not occur. The Frost Thermostat should be set to 5°C. The Pipe Thermostat will sense a rise in water temperature in the pipework and then switch the system off. It should be sited on the boiler return, set at 25°C and wired as below.

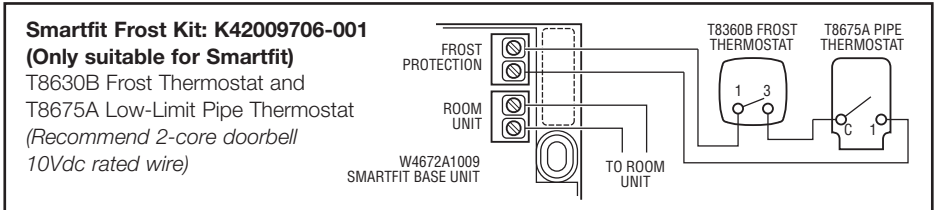
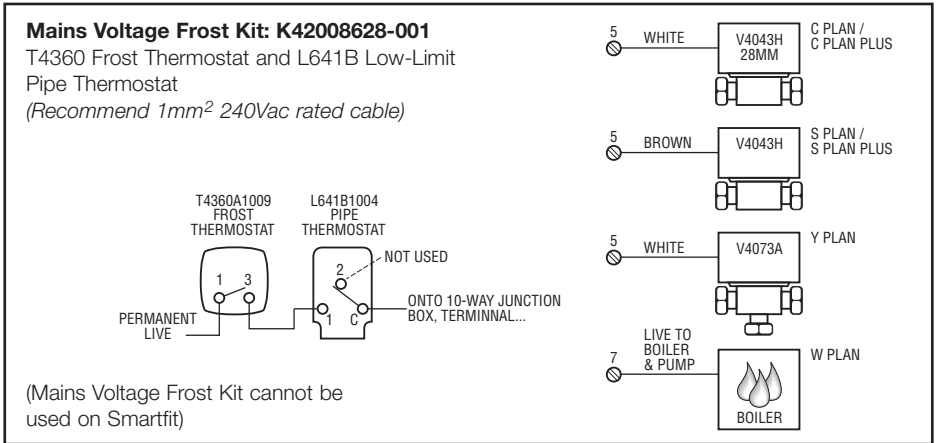

When a Frost Thermostat is installed on a central heating system, the fused spur should only be switched off for servicing and maintenance. If the heating system is to be switched off for any other reason, eg. holiday, then switching must only be carried out at the Programmer or Timeswitch, otherwise the Frost Protection is disabled.

Wiring Centre

A simple alternative to using this guide and a conventional junction box, is the Honeywell Sundial Plans Wiring Centre (Part number 42005748-001). This provides a clearly marked terminal block for each component in the system with each wire having its own terminal.

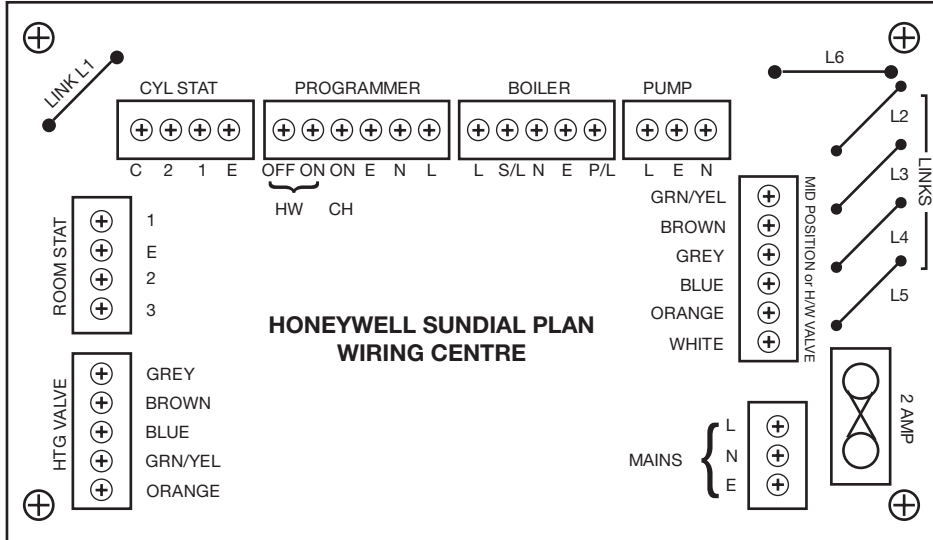

COMPONENTS LAYOUT

If using Programmer (not basic Time Clock) Cut link 1.

FOR FULLY PUMPED SYSTEMS

FOR S PLAN (two zone valves) Cut links L2 and L4.

If boiler requires pump overrun Cut link L3 also.

If using a **28mm or 1" BSP V4043H** the **WHITE** wire must be isolated and made safe. Do not connect to a terminal.

FOR Y PLAN (mid position valve) Cut links L4 and L5.

If boiler requires pump overrun Cut link L6 also.

FOR GRAVITY PRIMARY SYSTEMS

FOR C PLAN (one 28mm zone valve) Cut links L2 and L3.

If Room Thermostat is not being used, link terminals 1 and 3 at the **ROOM STAT** connector block.

For frost protection connect the FROST THERMOSTAT T4360A as follows:

S Plan

Frost thermostat Terminal 1 to HW OFF on programmer block. Frost thermostat Terminal 3 to WHITE on MID POS/HW VALVE terminal block.

Y Plan

Frost thermostat Terminal 1 to GREY and frost thermostat Terminal 3 to BROWN on HTG VALVE terminal block.

C Plan

Frost thermostat Terminal 1 to GREY and frost thermostat Terminal 3 to ORANGE on HTG VALVE terminal block.

BOILER CONNECTIONS

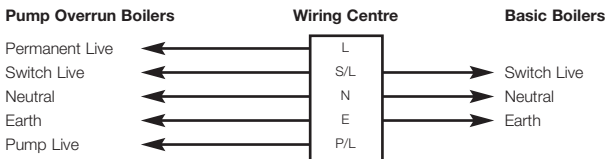

Wired Sundial Y Plan

The table opposite gives guidance on a quick electrical check for installed **Sundial Y Plans** to help in commissioning and to pin-point the source of any electrical problems.

Remember the **Golden Rule** when you have a problem. First of all **check your wiring**. Only start suspecting faulty components after you are satisfied all wiring is correct.

The following faulty notes will help to identify faulty components.

Cylinder Stat

First of all, make sure you have wired to the correct terminals.

Terminal C (common) is the **Left Hand** terminal.

Terminal 1 is the **Middle** terminal.

Terminal 2 is the **Right Hand** terminal.

Suspect the cylinder thermostat is faulty only if Terminal 1 does **not** become live when calling for Hot Water, or Terminal 2 does **not** become live when satisfied. (Make sure that Terminal C is live in both cases). While checking, disconnect Terminals 1 and 2 to prevent false readings due to backfeed.

Room Stat

- 1) Remove wire from Terminal 3.
- 2) Live to Terminal 1.
- 3) Turn stat to call, if no live on 3 then faulty.

Suspect the room stat is faulty only if Terminal 3 is not live when calling for heat. (Make sure Terminal 1 is live). While checking, disconnect wiring from Terminal 3 to prevent false readings due to backfeed.

Mid-Position Valve

Suspect the V4073A valve is faulty only if the valve does not operate as specified in the following checks (these should be done in order 1, 2, 3, 4, 5 and 6).

Valve open for Heating only

1. **Switch off mains supply**. Disconnect **Grey** and **White** wires from appropriate junction box terminals. Reconnect both **Grey** and **White** wires to permanent live terminal in junction box.
2. Switch on mains supply. Valve motor should now move to fully open heating Port A. The motor should stop automatically when Port A is open, and stay in this position as long as power is applied to **White** and **Grey** wires. When Port A is fully open, the **Orange** wire becomes live, to start pump and boiler.

Double check by feeling that Port A outlet is getting progressively warmer.

Valve open for DHW only

3. Switch off mains supply. The valve should now automatically return to open DHW Port B and close Heating Port A.
4. Isolate **Grey** and **White** wires and make safe. Remove cylinder stat wire from Terminal 6 in junction box and connect to permanent live. Switch on fused spur, cylinder thermostat must be set to call for heat, pump and boiler should start.

Valve open for both DHW and Heating

5. Switch off mains supply. Replace cylinder stat wire to Terminal 6. Isolate and make safe **Grey** wire and connect **White** wire to permanent live. Switch on mains supply, motor should now move to mid-position and stop automatically. Cylinder thermostat must be set to call for heat. Both ports A & B are now open for Hot Water and Heating. Boiler and pump should start. Double check by feeling that pipe outlets from ports A & B become progressively warmer.

6. Switch off mains supply, reconnect **White** and **Grey** wires to junction box terminals. If this check completes satisfactorily, the problem is not the valve, but elsewhere in the circuit.

Programmer

Suspect the programmer only:

- (a) After you have made sure that any links required are in place,
- (b) After you have made sure that the Programmer has power – to the correct terminal,
- (c) After you have made sure that the Programmer timing is set up correctly (see individual Programmer User Guide as appropriate),
- (d) If live does not appear at Heating ON Terminal when Heating only is selected on continuous or timed,
- (e) If live does not appear at Hot Water ON Terminal when Hot Water only is selected on continuous or timed,
- (f) If live does not appear on Hot Water OFF terminal with Hot Water OFF on programmer.

Wired Sundial Y Plan

Programmer Switch Position	Heating only selected	Hot Water only selected	Hot Water and Heating selected
Programmer	Live on both 'CH ON' & 'HW OFF' Terminals.	Live on 'HW ON' Terminal.	Live on both 'CH ON' & 'HW ON' Terminals.
T6360B Room Thermostat	Set to call for Heat. Live on Terminals 1 & 3.	No live on any terminal. (See note 2 for Terminal 3).	Set to call for Heat. Live on Terminals 1 & 3.
L641A Cylinder Thermostat	Nominal 90 volts. Live on Terminals 1 & 2 (Note Terminal 1 only becomes 240 volt live after V4073A valve opens and Boiler fires). (See notes below).	Set to call for Hot Water. Live on Terminals C & 1. (See note 2 for Terminal 2)	Set to call for Hot Water. Live on Terminals C & 1. (See note 2 for Terminal 2)
V4073A 3 Port Mid-Position Valve	Live on Grey, White and Orange wires. Valve opens to Port A for Central Heating (CH).	Live on Orange wire only (See note 2 for Grey and White wires) Valve not energised. Port B open for Domestic Hot Water (DHW).	Live on White wire and Orange wire. (See note 2 for Grey wire). Valve in mid position for CH and DHW.
Boiler and Pump	Boiler and pump fired via live feed from Orange wire.	Boiler and pump fired via live feed from Terminal 1 on cylinder stat.	Boiler and pump fired via live feed from Terminal 1 on cylinder stat and Orange wire.

NOTES

1. Check **must** only be made by a suitably qualified electrician.
2. Low A.C. voltage may appear on specified wire or terminals due to back feed from V4073A valve. If in doubt, disconnect **Grey** or **White** wire as appropriate, or check with meter for full 240V.
3. **Blue** wire on valve **must** be connected to neutral.
4. Terminal 2 on room thermostat **must** be connected to neutral.
5. Ensure that any links required in programmer are in place.
6. Earth connection (**Green/Yellow**) **must** be made on valve.
7. Earth connection not needed on room stat or cylinder stat.

SEE NOTES OPPOSITE IF YOU HAVE A PROBLEM

Wired Sundial S Plan and S Plan Plus

The table opposite gives guidance on a quick electrical check for installed wired **Sundial S Plan** and wired **S Plan Plus** to help in commissioning and to pin-point the source of any electrical problems.

Remember the **Golden Rule** when you have a problem. First of all **check your wiring**. Only start suspecting faulty components after you are satisfied all wiring is correct.

The following notes will help to identify faulty components.

Cylinder Stat

First of all, make sure you have wired to the correct terminals.

Terminal C (common) is the **Left Hand** terminal.

Terminal 1 is the **Middle** terminal.

Terminal 2 is the **Right Hand** terminal.

Suspect the cylinder thermostat is faulty only if Terminal C **not** live when calling for Hot Water.

Room Stat

1) Remove wire from Terminal 3.

2) Live to Terminal 1.

3) Turn stat to call, if no live on 3 then faulty.

Suspect the room stat is faulty only if Terminal 3 is not live when calling for heat. (Make sure Terminal 1 is live). While checking, disconnect wiring from Terminal 3 to prevent false readings due to backfeed.

Zone Valves

Suspect a motorised valve is faulty only:

1. If the motor fails to rotate with live applied to the **Brown** wire and neutral to the **Blue** wire. (Motor can be viewed with valve cover removed).

Note that the motor stops automatically when the valve is fully open and stays in this condition as long as live is applied to the **Brown** wire.

The valve automatically closes under spring return when live is removed from the

Brown wire.

2. The **Orange** wire only becomes live after the valve has fully opened (Make sure the **Grey** wire is live).
3. If the boiler and pump continues to run when the cylinder stat and room stat is satisfied and the clock is in OFF position.

Programmer

Suspect the programmer only:

- (a) After you have made sure that any links required are in place.
- (b) After you have made sure that the Programmer has power – to the correct Terminal.
- (c) After you have made sure that the Programmer timing is set up correctly (see individual Programmer User Guide as appropriate).
- (d) If live does not appear at Heating ON Terminal when Heating is selected on continuous or timed.
- (e) If live does not appear at Hot Water ON Terminal when Hot Water only is selected on continuous or timed.

Wired Sundial S Plan and S Plan Plus

Programmer Switch Position	Heating only selected	Hot Water only selected	Hot Water and Heating selected
Programmer	Live on 'CH ON' Terminal.	Live on 'HW ON' Terminal.	Live on both 'HW ON' & 'CH ON' Terminals.
T6360B Room Thermostat	Set to call for Heat. Live on Terminals 1 & 3.	No live on any terminal.	Set to call for Heat. Live on Terminals 1 & 3.
L641A Cylinder Thermostat	No live on any terminal.	Set to call for Hot Water. Live on Terminals C and 1.	Set to call for Hot Water. Live on Terminals C and 1.
V4043H Heating Zone Valve	Live on Brown , Grey and Orange wires.	Live on Grey and Orange wires.	Live on Brown , Grey and Orange wires.
V4043H Hot Water Zone Valve	Live on Grey and Orange wires.	Live on Brown , Grey and Orange wires.	Live on Brown , Grey and Orange wires.
Boiler and Pump	Boiler and pump fired via live feed from Orange wire.	Boiler and pump fired via live feed from Orange wire.	Boiler and pump fired via live feed from Orange wire.

NOTES

1. Check **must** only be made by a suitably qualified electrician.
2. **Grey** wire on both Heating and Hot Water zone valves **must** be connected to permanent live.
3. **Blue** wire on both Heating and Hot Water zone valves **must** be connected to neutral.
4. Terminal 2 on room thermostat **must** be connected to neutral.
5. Ensure that any links required in programmer are in place.
6. Earth connection (**Green/Yellow**) **must** be made on valve.
7. With 28mm or 1 inch V4043H valves the **White** wire is not used and **must** be made electrically safe.

SEE NOTES OPPOSITE IF YOU HAVE A PROBLEM

Wired Sundial C Plan

The table opposite gives guidance on a quick electrical check for installed **Sundial C Plans** to help in commissioning and to pin-point the source of any electrical problems.

Remember the **Golden Rule** when you have a problem. First of all **check your wiring**. Only start suspecting faulty components after you are satisfied all wiring is correct.

The following notes will help to identify faulty components.

Cylinder Stat

First of all, make sure you have wired to the correct terminals.

Terminal C (common) is the **Left Hand** terminal.

Terminal 1 is the **Middle** terminal.

Terminal 2 is the **Right Hand** terminal.

Suspect the cylinder thermostat is faulty only if Terminal C is **not** live when calling for Hot Water.

Room Stat

1) Remove wire from Terminal 3.

2) Live to Terminal 1.

3) Turn stat to call, if no live on 3 then faulty.

Suspect the room stat is faulty only if Terminal 3 is not live when calling for Heat. (Make sure Terminal 1 is live). While checking, disconnect wiring from Terminal 3 to prevent false readings due to backfeed.

Zone Valve

Suspect the valve is faulty only:

1. If the motor fails to rotate with live applied to the **Brown** wire and neutral to the **Blue** wire. (Motor can be viewed with valve cover removed).

Note that the motor stops automatically when the valve is fully open and stays in this condition as long as live is applied to the **Brown** wire.

2. If the boiler continues to run when the cylinder stat and/or room stat is satisfied and/or the clock is in OFF position.
3. (a) SWITCH OFF mains supply.
(b) Disconnect **Brown** wire to valve, and terminate safely.
(c) Disconnect **White** wire and re-connect to permanent live terminal at junction box.
(d) Disconnect pump live connection at junction box and re-connect to permanent live terminal.
(e) SWITCH ON mains supply.
(f) Valve should remain closed, **Orange** wire should become live to fire boiler.

4. (a) SWITCH OFF mains supply.
(b) Restore **White** wire and pump live connections to original positions at junction box.
(c) Connect **Brown** wire to permanent live terminal at junction box.
(d) Ensure **Grey** wire is connected to permanent live.
(e) SWITCH ON mains supply.

Valve should now motor open. When fully open, **Orange** wire should become live to fire Boiler.

SWITCH OFF mains supply. Restore **Brown** wire to original Terminal on junction box.

If these checks complete satisfactorily, the problem is not on valve but elsewhere in circuit.

Note that a V4043H1106 (28mm) or V4043H1080 (1 inch BSP) valve is required for the C Plan.

Programmer

Suspect the programmer only:

- (a) After you have made sure that any links required are in place.
- (b) After you have made sure that the Programmer has power – to the correct terminal.
- (c) After you have made sure that the Programmer timing is set up correctly (see individual Programmer User Guide as appropriate).
- (d) If live does not appear at Heating ON Terminal when Heating only is selected on continuous or timed.
- (e) If live does not appear at Hot Water ON Terminal when Hot Water only is selected on continuous or timed.

Wired Sundial C Plan

Programmer Switch Position	Heating only selected	Hot Water only selected	Hot Water and Heating selected
Programmer	Live on 'CH ON' Terminal.	Live on 'HW ON' Terminal.	Live on both 'HW ON' & 'CH ON' Terminals.
T6360B Room Thermostat	Set to call for Heat. Live on Terminals 1 & 3.	No live on any terminal.	Set to call for Heat. Live on Terminals 1 & 3.
L641A Cylinder Thermostat	No live on any Terminal.	Set to call for Hot Water. Live on Terminals C & 1.	Set to call for Hot Water. Live on Terminals C & 1.
V4043H Hot Water Zone Valve	Live on Grey, White and Orange wires.	Live on Brown, Grey and Orange wires.	Live on Brown, White, Grey and Orange wires.
Boiler and Pump	Boiler fired via Orange wire, room stat Terminal 3 runs pump.	Boiler fired via Orange wire.	Boiler fired via Orange wire, room stat Terminal 3 runs pump.

NOTES

1. Check **must** only be made by a suitably qualified electrician.
2. **Grey** wire on both Heating and Hot Water zone valves **must** be connected to permanent live.
3. **Blue** wire on both Heating and Hot Water zone valves **must** be connected to neutral.
4. Terminal 2 on room thermostat **must** be connected to neutral.
5. Ensure that any links required in programmer are in place.
6. Earth connection (**Green/Yellow**) **must** be made on valve.
7. With 28mm or 1 inch V4043H valves the **White** wire is not used and **must** be made electrically safe.

SEE NOTES OPPOSITE IF YOU HAVE A PROBLEM

Wired Sundial W Plan

The table opposite gives guidance on a quick electrical check for installed wired **Sundial W Plans** to help in commissioning and to pin-point the source of any electrical problems.

Remember the **Golden Rule** when you have a problem. First of all **check your wiring**. Only start suspecting faulty components after you are satisfied all wiring is correct.

The following notes will help to identify faulty components.

Cylinder Stat

First of all, make sure you have wired to the correct terminals.

Terminal C (common) is the **Left Hand** terminal.

Terminal 1 is the **Middle** terminal.

Terminal 2 is the **Right Hand** terminal.

Suspect the cylinder thermostat is faulty only if Terminal 1 is **not** live when calling for Hot Water, or Terminal 2 is **not** live when satisfied. (Make sure that Terminal C is live in both cases). While checking, disconnect Terminals 1 and 2 to prevent false readings due to backfeed.

Room Stat

- 1) Remove wire from Terminal 3.
- 2) Live to Terminal 1.
- 3) Turn stat to call, if no live on 3 then faulty.

Suspect the room stat is faulty only if Terminal 3 is not live when calling for heat. (Make sure Terminal 1 is live). While checking, disconnect wiring from Terminal 3 to prevent false readings due to backfeed.

Diverter Valve V4044C

Suspect the V4044C valve is faulty only if the valve does not operate as specified in the following checks (these should be done in order 1, 2, 3 and 4).

Valve open for Heating only

1. Switch off mains supply. Disconnect **Brown** wire from appropriate terminal and connect to permanent live Terminal in junction box.
2. Switch on mains supply. Valve motor should now rotate to fully open heating Port A.

Valve opens for DHW only

3. Switch off mains supply. The valve should automatically spring return to open DHW Port B and close Port A.
4. Reconnect **Brown** wire to Terminal 5.

Programmer

Suspect the programmer only:

- (a) After you have made sure that any links required are in place.
- (b) After you have made sure that the Programmer has power – to the correct terminal.
- (c) After you have made sure that the Programmer timing is set up correctly (see individual Programmer User Guide as appropriate).
- (d) If live does not appear at Heating ON Terminal when Heating is selected on continuous or timed.
- (e) If live does not appear at Hot Water ON Terminal when Hot Water only is selected on continuous or timed.

Wired Sundial W Plan

Programmer Switch Position	Hot Water only selected	Hot Water and Heating selected
Programmer	Live on 'HW ON' Terminal.	Live on both 'CH ON' and 'HW ON' Terminals.
T6360B Room Thermostat	No live on Terminals 1 or 3.	Set to call for Heat. Live on Terminals 1 & 3.
L641A Cylinder Thermostat	Set to call for Hot Water. Live on Terminals C & 1.	Set to call for Hot Water. Live on Terminals C & 1.
V4044C Diverter Valve	Valve not energised Port B open for Domestic Hot Water.	Live on Brown wire only. When D.H.W. satisfied.
Boiler and Pump	Boiler and pump fired via live feed from Terminal C on cylinder stat.	Boiler and pump fired via live feed from Terminal C on cylinder stat and 3 on room stat.

NOTES

1. Check **must** only be made by a suitably qualified electrician.
2. **Blue** wire on diverter valve **must** be connected to neutral.
3. Terminal 2 on room thermostat **must** be connected to neutral.
4. Ensure that any links required in programmer are in place.
5. Earth connection (**Green/Yellow**) **must** be made on valve.

SEE NOTES OPPOSITE IF YOU HAVE A PROBLEM

Energy Saving

On/Off Control

On/Off control is the method of control used by most heating systems in the UK. The controls simply switch the current supplied to the boiler on or off at different times.

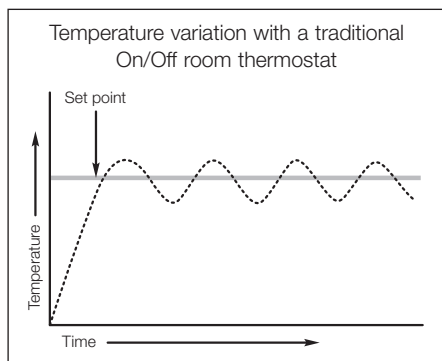

TPI Control

Time Proportional and Integral (TPI) control is a method of calculating the demand from a room thermostat, controlling the boiler so that it fires for shorter periods as the temperature approaches the set point. This can offer savings of up to 10% of energy consumption (in a single cycle steady state test).

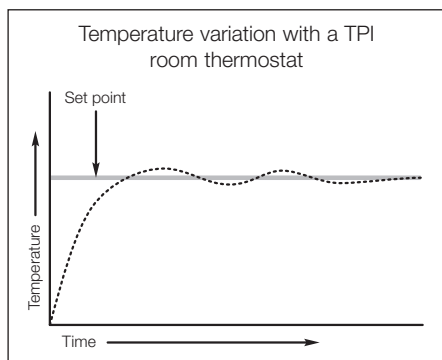

OpenTherm

OpenTherm provides more precise control on the boiler than TPI through the control of the gas valve. It allows the amount of heat provided by the boiler to be controlled to match the varying demand signal. By reducing the flow temperature to a minimum as it leaves the boiler, the return temperature is kept below the dew point (55°C) whenever possible, thus allowing the boiler to operate in condensing mode.

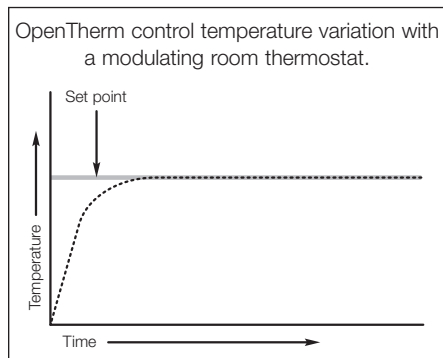

Optimisation

Optimisation is a series of optional features that save energy while making the user as comfortable as possible. It does not apply to hot water, only heating.

Optimum Start

To save energy, let the controls work out when to come on to suit when you want to be warm. Every day the boiler will start at the latest possible moment depending on the weather.

Energy Saving

Delayed Start

Once you have programmed your earliest start time, the controls will delay the boiler firing time on warmer days, when it is possible to save energy.

Optimum Stop

Saves energy and money by switching off before the normal programme time whenever possible.

Energy saving with room thermostats

Turning a room thermostat down by 1°C can reduce heating bills by 10% (Government statistic on www.energysavingtrust.org.uk). In general the average human body is insensitive to a band of temperature of 3°C. Therefore your customer won't feel the difference in temperature, but will notice a difference in their pocket.

T6360 Classic room thermostat



DT90E Digital room thermostat



CM927 Wireless programmable room thermostat



Energy saving technology in Honeywell thermostats

Product	T6360	Y6630D	DT90E	DT92E	CM907	CM927
Standard On/Off	✓					
TPI		✓	✓	✓	✓	✓
Wired	✓		✓		✓	
Wireless		✓		✓		✓
Wireless 2 way 				✓		
Optimum start					✓	✓
1 day / 7 day					1	7
Battery life yrs		2	4	2	2	2
Temperature range (°C)	10 - 30	10 - 30	5 - 35	5 - 35	5 - 35	5 - 35

Product Selection

On the following pages are highlights of the Honeywell products available, for the full list see www.honeywelluk.com

ST9000 Programmers and Timeswitches



- ST9100A1008 1 day Timeswitch
- ST9100C1006 7 day Timeswitch
- ST9400A1002 1 day Full programmer
- ST9400C1000 7 day Full programmer
- ST9100S1007 1 day Service timeswitch
- ST9400S1001 1 day Service programmer
- ST9500C1015 7 day Two zone programmer

Sundial RF² Wireless Enabled Packs



- Y9120H1009 Pack 1
(wireless enabled timeswitch and wireless room thermostat)
- Y9420H1008 Pack 2
(wireless enabled programmer and wireless room thermostat)
- Y9420S1005 Pack 3
(wireless enabled programmer, wireless room thermostat and cylinder thermostat)

Classic Programmers



- ST699B1002 1 day programmer
- ST799A1003 7 day programmer

Motorised Valves



- V4043H1056 Two port motorised zone valve with 22mm compression
- V4044C1288 Three port motorised diverter valve with 22mm compression
- V4073A1039 Three port motorised mid-position diverter valve with 22mm compression

Cylinder Thermostat



- L641A1039 Cylinder thermostat

Product Selection

Classic Room Thermostat



- T6360B1028 Room thermostat
- T6360B1069 Tamperproof room thermostat
- T6360B1036 Room thermostat with indicator
- T6360B1085 Room thermostat with 1-5 dial
- T4360B1015 Room thermostat 16A rated

CM900 Programmable Thermostat Range



- CMT901A1044
- CM901 1 day Programmable thermostat
- CMT907A1041
- CM907 7 day Programmable thermostat
- CMT921A1042
- CM921 1 day Wireless programmable thermostat
- CMT927A1049
- CM927 7 day Wireless programmable thermostat

Wireless Analogue Room Thermostat



- Y6630D1007
- Wireless room thermostat

Digital Room Thermostat



- DT90E1012
- Wired digital room thermostat
- DT92E1000
- Wireless digital room thermostat

Smartfit



- Y4610A1002 Y plan 1 day
- Y4610A1010 Y plan 7 day
- Y4610A1028 S plan 1 day
- Y4610A1036 S plan 7 day

Product Selection

Wireless Zoning System



YZ667A1060
CM Zone Wireless zoning system contains six wireless thermostatic radiator valves, one wireless programmable room thermostat and one receiver.

Wireless Radiator Thermostats



HR80UK Wireless radiator thermostat controller (fits standard radiator valve bodies as shown)

Underfloor heating



HCE80 Wireless underfloor heating controller

Radiator Thermostats



VT117 Traditional radiator thermostat
VT200 Classic radiator thermostat



VH117E Manual radiator valve



VTL120 Radiator thermostat and lockshield valve

Most TRVs available as angled or straight.
For full catalogue numbers, refer to our product catalogue.

Product Selection

Automatic Air vent



EA122 – AB Automatic air vent

Automatic Bypass Valves



DU144A1001 Straight automatic bypass valve
DU145 - 3/4B Angled automatic bypass valve

Thermostatic Mixing Valves



TM200VP TMV3 scheme approved
thermosttic mixing valve
TM300 TMV2 scheme approved thermosttic
mixing valve

Pressure Reducing Valves



D04FS Pressure reducing valve
D05 Pressure reducing valve
D06F Pressure reducing valve

Balancing Valves



Kombi 4 Circulation throttle and balancing
valve
Kombi 3 Plus flow regulating and balancing
valve

Filling Valves



VF06 Sealed system filling valve

Website

www.honeywelluk.com

The screenshot shows the Honeywell UK website for Heating Controls. At the top, there is a navigation bar with links: HEATING PRODUCTS, SUPPORT SERVICES, ENERGY SAVING, DOWNLOADS, NEWS & EVENTS, CONTACT, and a search bar. Below this is a header for 'Honeywell United Kingdom Heating Controls'. The main content area is divided into several sections: 'HOME', 'LATEST NEWS' (with a news item from 21/02/11), 'ABOUT HONEYWELL', and 'PRODUCTS'. The 'PRODUCTS' section lists: Radiator Thermostats, Programmable Thermostats, Systems, Time Controls, Temperature Controls, Valves, Spare Parts, Underfloor Heating, and Discontinued Products. A 'RELATED BITES' sidebar on the right includes 'Water Controls', 'Building Controls', and a 'FIND AN INSTALLER' section with a search bar. At the bottom, there is a footer with links for Terms & Conditions, Privacy Statement, Site Map, About Us, Useful Links, DM Zone Handbook, and White Space Combustion Controls, along with a copyright notice for Honeywell International Inc. 2004-2010.

A vast amount of information is available on our websites including:

- Full range of Honeywell heating and water products
- Past products
- Download literature; installer guides, user guides, sales literature and catalogue
- FAQs; wiring diagrams, energy saving, TPI control, OpenTherm and Optimisation
- Installer training courses; find a course in your area and booking form
- Building regulations; how to comply with building regulations
- Spare parts - sensors for programmable room thermostats and heads for motorized zone valves
- Energy saving advice - how to maximise energy saving in a central heating system
- News - product launches, Government schemes and change in regulations

See also www.honeywellukwater.com

Training

Installer Training courses

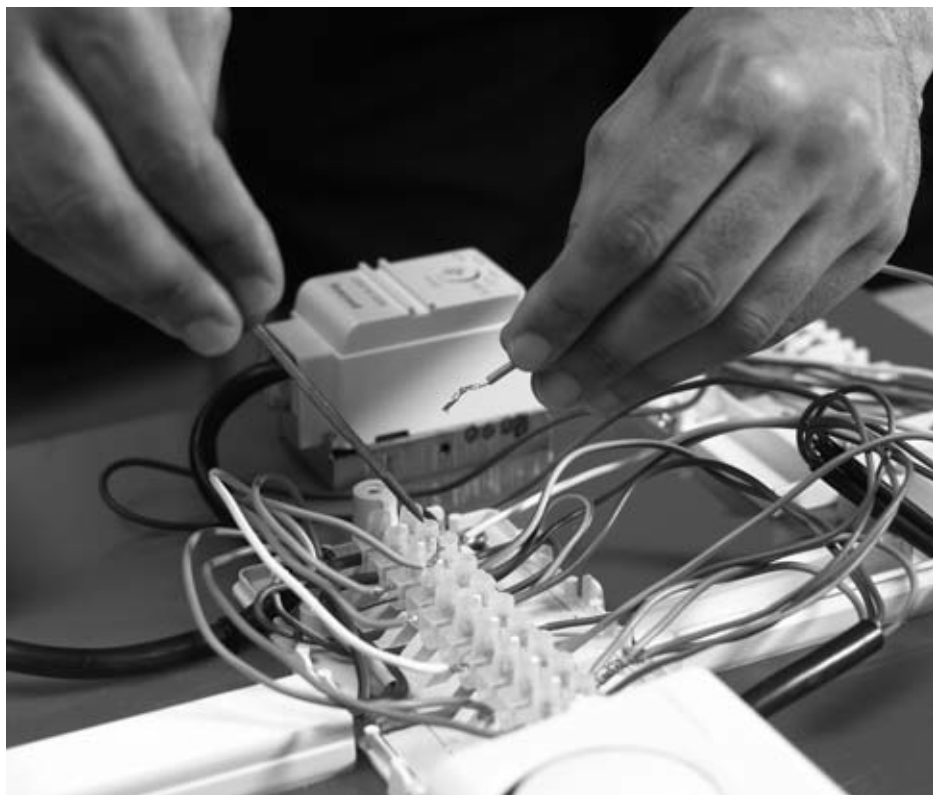

Expand your knowledge of heating and water controls with expert training on our one day Installer courses, all for £30.

- Hands on wiring
- Fault finding
- Learn about the latest products
- Energy conservation
- Part L Building Regulations
- Wireless controls
- Zoning
- Smartfit
- Sundial plans
- Frost protection
- Control selection

Available across UK and Ireland.

Tel: 01344 656352

Email: installer.training@honeywell.com

Web: www.honeywelluk.com

Notes

Notes

Helping you control your world

Honeywell has been manufacturing central heating controls for over 100 years and is the UK leader for quality, efficiency and reliability.

Honeywell
Honeywell House,
Bracknell,
Berkshire RG12 1EB

Tel: 01344 656000
Fax: 01344 656240
Email: insidesales@honeywell.com
www.honeywelluk.com



Honeywell

This brochure was produced on total chlorine-free paper from cultivated forests.