

# SUNDIAL S PLAN

## S PLAN

### FEATURES

- Independent control of heating zone
- Independent control of domestic hot water temperature
- Pump and boiler switched off when space & hot water temperature requirements are satisfied
- Additional heating zones may be provided

### OPTIONS

- Programmable thermostats in heating zone to provide 'Best Practice' system
- Radiator thermostats may be fitted to provide temperature control in selected areas
- CM Zone can provide wireless boiler interlock for individual radiator control

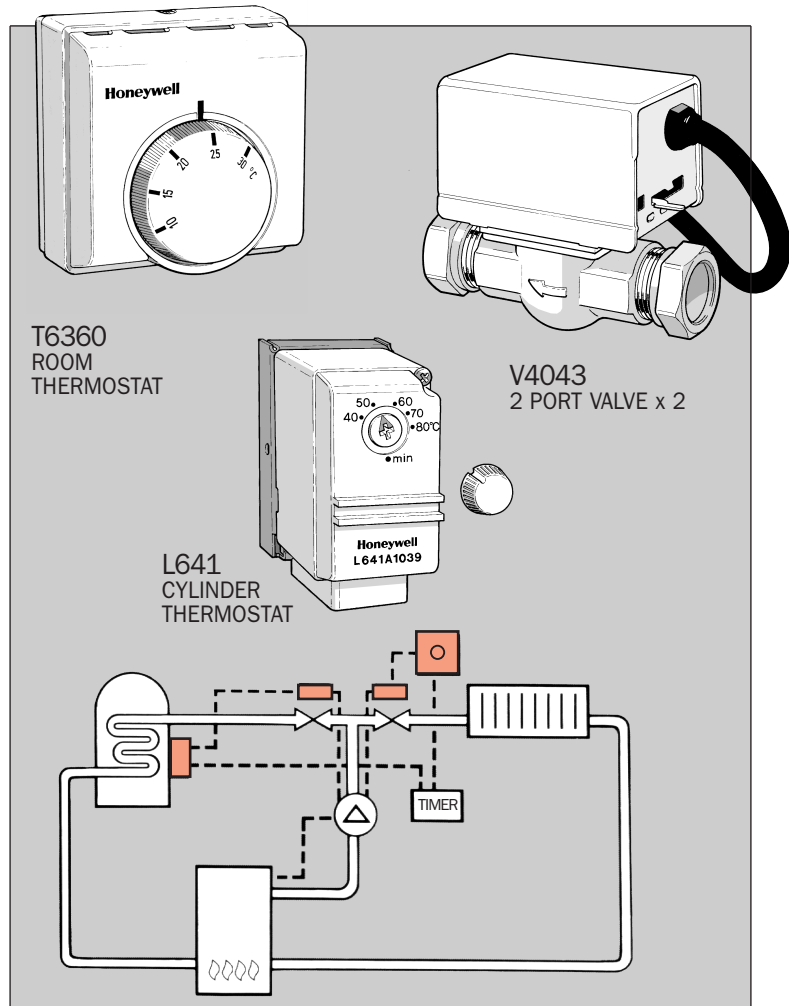

### APPLICATION

The Sundial S Plan is designed to provide independent time and temperature control of both heating and hot water circuits in fully pumped central heating installations.

Sundial S Plan satisfies the requirements of the Building Regulations Part L1 when used in conjunction with radiator thermostats and Automatic Bypass Valve.

For systems in dwellings with a floor area greater than 150m<sup>2</sup> Sundial S Plan Plus must be used (see 2.3).

**SUNDIAL SYSTEMS**

**Honeywell**

## Installation

**Valves** - The zone valves should be fitted on the system flow pipe after the cold feed, expansion and pump. Water flow must be in the direction of the arrow.

**Room Thermostat** - The thermostat must be located where not subject to extraneous heat gains, direct sunlight or draughts.

**Cylinder Thermostat** - For optimum performance the thermostat should be located between  $\frac{1}{4}$  and  $\frac{1}{3}$  up the cylinder from the floor.

## Time Control

**Standard Practice** - A 2 channel programmer to control the HW and heating zones.

**Best Practice** - A time switch to control HW and a programmable thermostat for the heating zone.

**Bypass Valve** - An automatic bypass valve should be fitted to the heating system to stop wastage of energy and prevent increased pressure within the circuit.

## Operation

**Heating Only** - On a demand for heat from the room thermostat the heating valve is opened and the pump and boiler are switched on via the valve auxiliary switch. The hot water zone valve remains closed.

**Hot Water Only** - On a demand for heat from the cylinder thermostat the hot water valve is opened and the pump and boiler are switched on via the auxiliary switch. The heating zone valve remains closed.

**Heating and Hot Water** - When both thermostats demand heat, the valves are opened and pump and boiler are switched on via the auxiliary switches.

## Specification

### Standard Sundial S Plan comprises:

2 x V4043H1106	: 22 or 28mm 2 port zone valves
L641A1039	: Strap-on cylinder thermostat
T6360B1028	: Room thermostat
ST9400C1000 or ST9400A1002	: 7 day full programmer : : 1 day full programmer

### Automatic Bypass Valve

DU144A1001	: 22mm straight auto bypass valve
DU145 - $\frac{3}{4}$ B	: 22mm angled auto bypass valve

### Optional components

Y6630D1007	: Wireless analogue room thermostat
T6620B1008	: DT200 digital room thermostat

### Best Practice

CMT901A1044	: 1 day programmable thermostat
CMT907A1041	: 7 day programmable thermostat

### Frost protection

T4360A1009	: Frost Thermostat
L641B1004	: Low limit Pipe Thermostat

## Typical Wiring

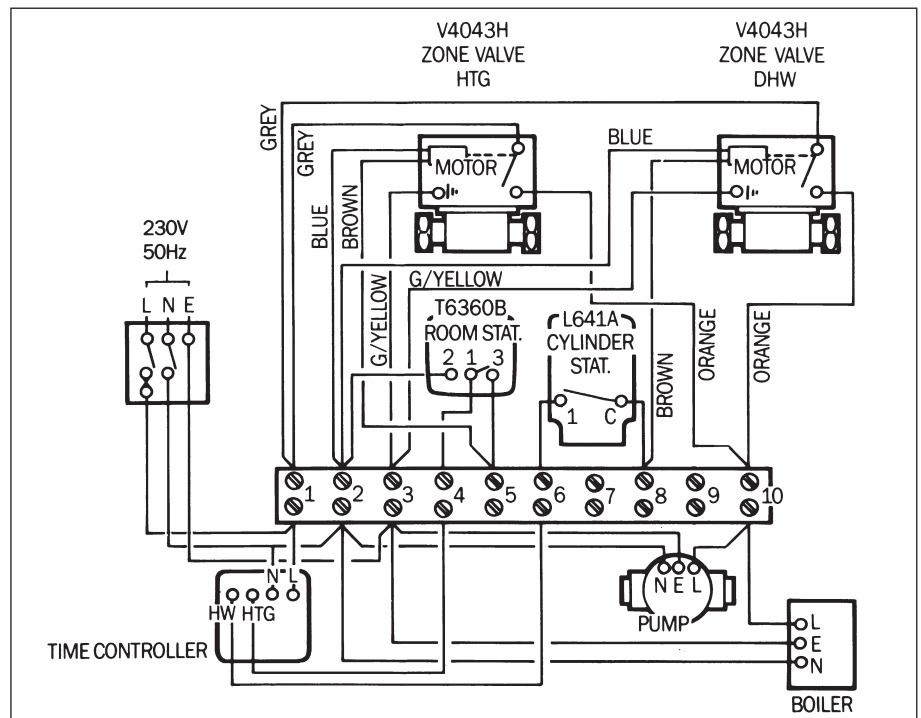

Note: It is recommended that either the 10 way Junction Box or Sundial Wiring Centre should be used to ensure first time, fault free wiring.