

inta

Vista Shower Mixing Valves

90032CP & 90033CP

Installation and Maintenance Instructions

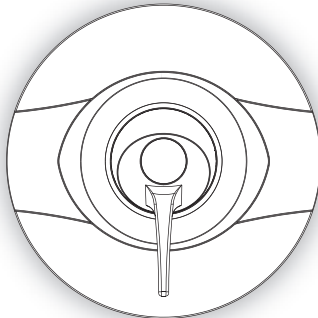
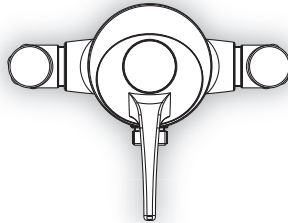

In this procedure document we have endeavoured to make the information as accurate as possible.

We cannot accept any responsibility should it be found that in any respect the information is inaccurate or incomplete or becomes so as a result of further developments or otherwise.

© Intatec Ltd. 2011

inta

Intatec Ltd

Airfield Industrial Estate

Hixon

Staffordshire

ST18 0PF

Tel: **01889 272 180**

Fax: **01889 272 181**

email: **sales@intatec.co.uk**

web: **www.intatec.co.uk**

Introduction

This installation guide has been produced for the Vista concealed and exposed thermostatic sequential shower mixing valves. These instructions cover the installation, operation and maintenance. Please read the enclosed instructions before commencing the installation of this product, please note;

We recommend that the installation of any Inta product is carried out by an approved installer.

The installation must be carried out strictly in accordance with the Water Supply (Water Fitting) Regulations 1999 and any local authority regulations.

If in doubt, we would recommend that you contact either your local water authority, the secretary of the Water Regulations Committee at WRc on Tel: 01495 248454 or Institute of Plumbing on Tel: 01708 472791.

All products **MUST** be re-commissioned to suit site conditions to ensure optimum performance levels of the product are obtained.

Safety

This thermostatic shower must be installed and commissioned correctly to ensure that water is supplied at a safe temperature to suit the users.

43°C is the maximum mixed water temperature from a shower mixer. The maximum temperature takes account of the allowable tolerances inherent in thermostatic shower mixers and temperature losses.

It is not a safe washing Temperature for adults or children.

The British Burns Association recommends 37 to 37.5°C as a comfortable washing temperature for children. In premises covered by the Care Standard Act 2000, the maximum mixed water outlet temperature is 43°C.

Products

Vista Exposed Thermostatic Sequential Control Shower.	90030CP
Vista Concealed Thermostatic Sequential Control Shower.	90032CP
Vista Exposed Thermostatic Sequential Control Shower with top and bottom outlets.	90033CP

Check Content

Before commencing remove all components from packaging and check each component with the contents list.

Ensure all parts are present, before discarding any packaging. If any parts are missing, do not attempt to install your Inta shower valve until the missing parts have been obtained.

Components - Exposed

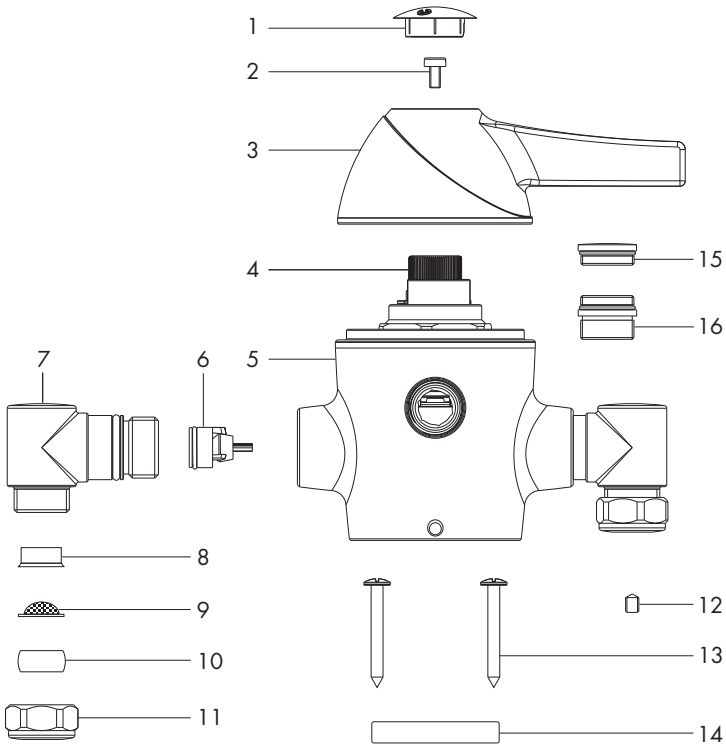

Item	Qty	Component	Item	Qty	Component
1	1	Indice	9	2	Filter
2	1	Screw	10	2	Olive
3	1	Flow/Temperature control	11	2	Compression nut
4	1	Thermostatic cartridge	12	1	Grub screw
5	1	Body	13	2	Fixing screw
6	2	Check valve	14	1	Back plate
7	2	Elbow	15*	1	Blank plug
8	2	Flow regulator	16*	1	Shower connector

* only applies to 90033CP

Components - Concealed

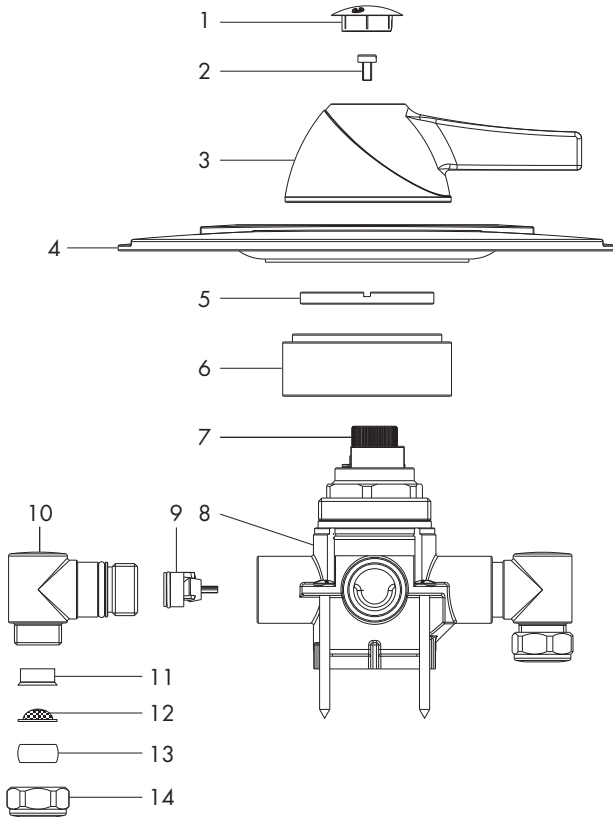

Item	Qty	Component	Item	Qty	Component
1	1	Indice	8	1	Body and fixing screws
2	1	Screw	9	2	Check valve
3	1	Flow/Temperature control	10	2	Elbow
4	1	Wall plate	11	2	Flow regulator
5	1	Fixing ring	12	2	Filter
6	1	Sleeve	13	2	Olive
7	1	Thermostatic cartridge	14	2	Compression nut

Technical Data

This Inta Vista thermostatic shower valve is suitable for installations on all types of plumbing systems, including gravity supplies, fully pumped, modulating combination boiler, unvented water heater and unbalanced supplies i.e. Cold Mains & Tank Fed Hot. They are not suitable for non-modulating combination boilers.

Max Inlet Pressure (Static)	12 bar	Max Inlet Temperature	85°C
Max Inlet Pressure (Dynamic)	5 bar	Pre Set Factory Temp Setting	43°C
Min Operating Pressure (Dynamic)	0.2 bar	Temperature Stability	±2°C
Max Unbalanced Pressure Ratio (with flow regulator)	15:1	Min Temp Differential to ensure fail-safe between hot and cold supplies	10°C
Max Unbalanced Pressure Ratio (without flow regulator)	5:1		
Outlet Connections - Body	G½		

Unvented Mains Pressure System

The drawing shows a typical installation of a shower mixing valve in conjunction with an unvented hot water system. This type of installation must be carried out in accordance with Part G of the Building Regulations.

Whilst pressures are theoretically equal (balanced) most unvented hot systems have a pressure reducing valve on the incoming cold water prior to the hot water storage vessel. This means that the hot and cold pressures can be significantly different.

Most unvented systems use an inlet manifold located directly after the pressure reducing valve.

It is recommended that the cold supply be taken from one of the outlets of the manifold directly to the shower as an independent supply.

For systems without a manifold unit after the pressure reducing valve and where the cold water supply pressure is significantly higher than the hot supply we recommend that a separate pressure reducing valve is fitted to the cold supply, as close as possible to the shower valve and with no draw off points between it and the shower valve.

Flow regulators are required for installations where a PRV is not fitted to ensure simultaneous demand is accounted for.

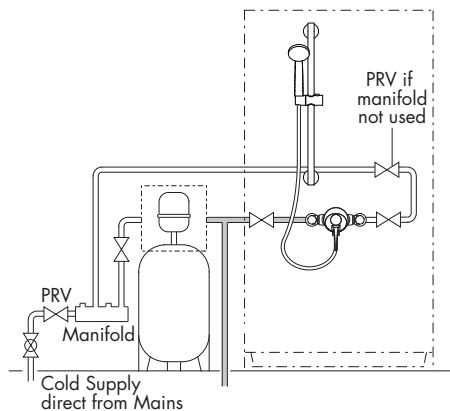

Pumped Systems

Pumped systems use a booster pump to increase the pressure of the gravity fed water supplies.

These booster pumps are used where the head of water is insufficient to provide a satisfactory shower or where a high performance shower is required.

Please ensure that the performance of the pump is matched to suit the shower.

Follow the instructions for gravity fed installations taking into account the installation requirements of the pump.

Ensure that the hot and cold water storage capacity is sufficient to supply the shower and any other draw off points that may be used simultaneously.

Most pumps require a minimum head of water to allow the flow switches to operate automatically. Where this is not available a negative head kit may be required to operate the pump.

Please consult the pump manufacturer's installation requirements

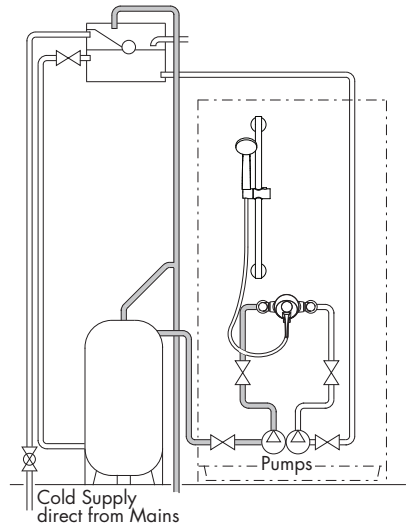

Modulating Combi Boiler / Instantaneous Gas Water Heater

The drawing shows a typical installation of a shower valve in conjunction with a combination boiler.

Combi boilers will produce a constant flow of water at a temperature within its operating range. However we recommend that the system should supply hot water in excess of 60°C.

The hot water flow rates are dependant upon the type of boiler / heater used and the temperature rise required to heat the cold water to the required temperature.

The cold water flow rates may be much greater as they are generally unrestricted from the mains cold water supply. To ensure relatively balanced flow rates, we recommend that a pressure reducing valve or 6 l/min flow regulator is fitted in the cold water supply pipe.

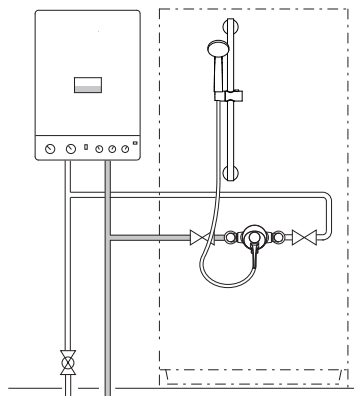

Gravity System

The drawing shows a typical installation of a shower valve on a gravity supplied system.

Please note the minimum head pressure required to ensure correct operation of the valve. In accordance with good plumbing practice, we recommend that a totally independent hot and cold water supply be taken to the valve.

The cold water supply must be connected directly to the water cistern. The hot water supply should be connected to the hot water cylinder via an Essex flange or Sussex flange or to the vent or a draw off pipe as close as possible to the top of the cylinder.

For equal tank fed pressures there is no need to fit the flow regulators. This installation is the recommended minimum for gravity supplies.

For systems with less than 2 metre head pressure, we recommend that a suitable booster pump is fitted to increase the supply pressure.

Cold Mains & Gravity Hot Supplies

If the cold supply to the shower is direct from the cold water mains and the hot water supply is gravity fed from the cold water cistern via the hot water cylinder you **MUST** fit a pressure reducing valve or a 6 l/min flow regulator.

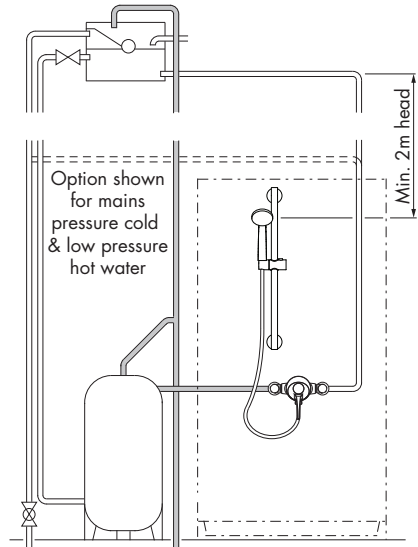

Dimensions - Exposed Valve

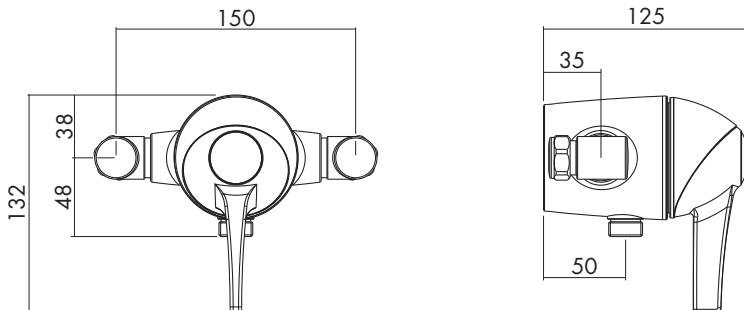

Dimensions - Concealed Valve

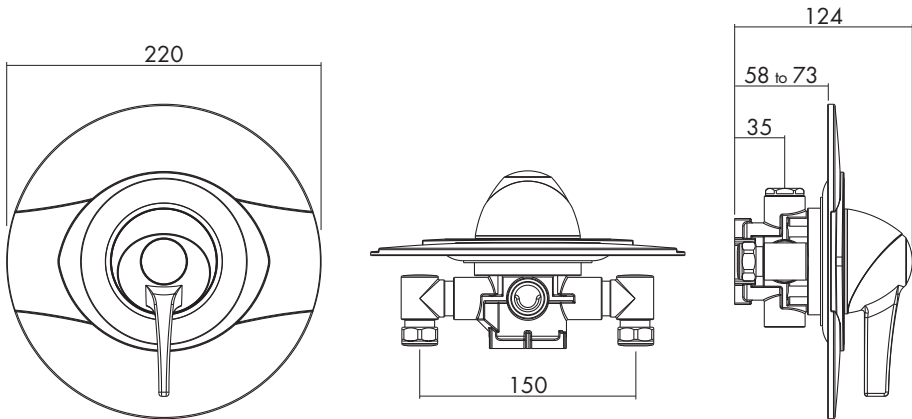

Site Preparation - General

It is important to plan the installation thoroughly to suit site conditions before commencing.

- Before commencing the installation ensure site conditions are suitable.
- Depending upon the model, the shower valve is designed for exposed or concealed pipework, whether in a solid or studded wall.
- The thickness of wall tiles, plaster or plaster board should all be considered when positioning the shower valve and routing the hot and cold supply pipes.
- The concealed shower valve must protrude sufficiently from the finished tiled surface to allow the concealing plate and control handle to be fitted.
- Ensure the shower valve will be horizontal when installed.
- The supply pipes can come from below, above, the side or through the wall.
- The concealed shower valve must be installed securely into the wall. If not embedded into the wall with plaster the shower valve must be fixed secure to the studding using screws in the 2 mounting holes.
- Each shower valve is supplied with integral non return valves in the cold and hot inlet tail pieces to prevent cross contamination of the water supplies. Additional check valves may be necessary in certain circumstances to comply with the Water Regulations. With flexible hose kits, where the hand set is capable of falling within 25 mm of the top of the shower tray, additional backflow prevention devices may be required.

Site Preparation - General

- Where possible, 22 mm hot and cold supplies should be used as close to the valve as possible and pipe runs should be kept to a minimum to maintain flow rates on low pressure installations.

NOTE: The inlets connections to the elbows to the shower valve are 15mm compression.

- Two 6 litre per minute flow regulators are supplied with the shower valve for when inlet pressures exceed 1.0 bar.
- The whole system should be thoroughly flushed, prior to connecting of the hot and cold water supplies to the shower valve, to remove any debris that may be in the supply pipework.
- Ensure there are no joint leaks before finishing the wall.
- Isolation valves must be fitted in an accessible position to both the hot and cold supplies should the valve need to be isolated in the future for servicing.

Site Preparation - Exposed Valve

Ensure the hot and cold supplies are positioned correctly to connect to the shower valve and the main compression joints are accessible for future servicing.

When facing the shower valve the hot water supply should be on the left and the cold on the right.

Ensure the valve is positioned to allow the shower kit to be installed at the required height to suit the tallest user.

Apply a bead of mastic to the back of the mounting back plate and fit to the wall in the required position using the appropriate wall plugs to suit the wall type.

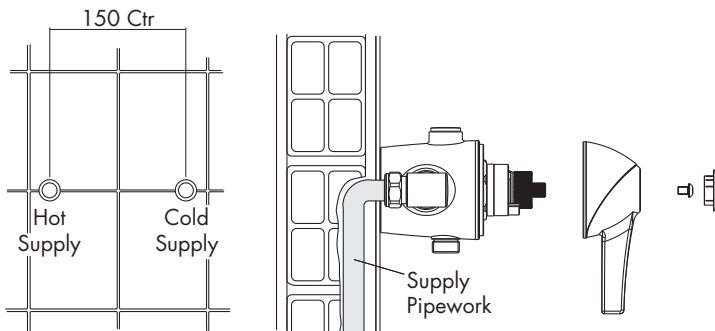

90033CP Shown

Connection - Exposed Valve

The 90030CP shower valve has a bottom ½" male shower connector, the position of which cannot be changed, suitable for use with a flexible hose kit.

The 90033CP shower valve is supplied with both the ½" bottom male connector and the ½" blanking plug fitted.

When used with a fixed riser kit, the shower connector can be moved to the upper threaded hole using a 12 mm Allen key. The blanking plug must then be fitted into the bottom threaded hole using a 6 mm Allen key.

Fit the valve body to the back plate and secure having first fitted any required flow regulators.

Connect the hot and cold supplies to the valve using the 15mm compression joints and check the joints for leakage.

Apply a bead of mastic to seal the joints around the hot and cold supply pipes and the joint between the wall and the mounting plate/valve.

Check the function of the valve, the maximum temperature should not exceed 43°C. If the maximum mixed water temperature exceeds this the valve must be re-calibrated to suit site conditions.

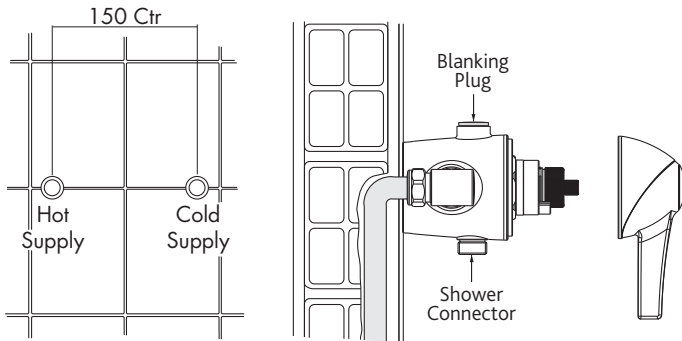

90033CP Shown

Site Preparation - Concealed Valve

Prepare the cavity to receive the valve, ensure the hot and cold supplies are positioned correctly and isolation valves are fitted in an accessible position.

When facing the shower valve the hot water supply should be on the left and the cold on the right.

Fit the back plate to the wall.

In a stud wall it may be necessary to fit a batten to support the valve.

Ensure the valve is positioned to allow the shower kit to be installed at the required height to suit the tallest user.

Site Preparation - Concealed Valve

Depth of cavity 62 mm minimum to 79 mm maximum to the finished wall surface including wall tiles.

Ensure the second outlet is blanked off if not used.

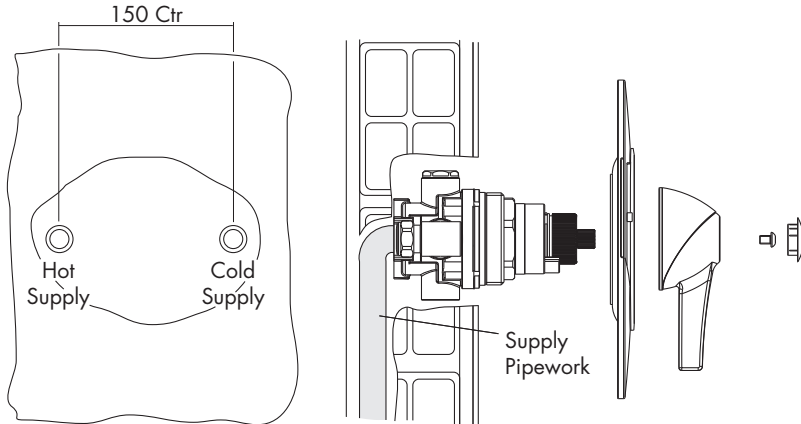

NOTE: Wall elbow available for concealed installation for use with flexible hose shower kit.

Connection - Concealed Valve

The 90032CP shower valve has both a bottom and top $\frac{1}{2}$ " female connection, ensure the blanking plug is fitted into the outlet which is not required and tighten to make a water tight joint.

Fit the valve body to the wall and secure, having first fitted any flow regulators into the elbows as required.

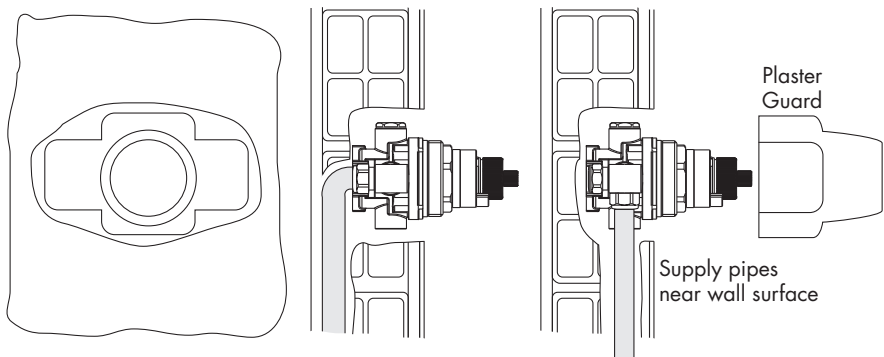

Connection - Concealed Valve

Connect the hot and cold supplies to the valve using the compression joints provided. The elbows are designed to allow access to the filters and check valves without the need to disconnect the valve from the pipework.

A plaster guard is included to protect the valve whilst the wall surface is finished, including the tiling.

Simply fit the guard over the valve and remove when the wall surface is finished.

Turn on the water supplies and check for leaks.

Check the function of the valve, the maximum temperature should not exceed 43°C. If the maximum mixed water temperature exceeds this the valve must be re-calibrated to suit site conditions.

Concealed Valve - Fitting the Concealing Plate

Once the valve has been installed, all the connections have been checked for leakage and the surface of the wall has been finished the concealing plate can be fitted.

It may be necessary to lubricate the seal in the centre of the concealing plate to ease assembly onto the valve body.

Apply a bead of mastic to the outer edge, on the back of the concealing plate and slide the plate over the valve body and press firmly to the wall.

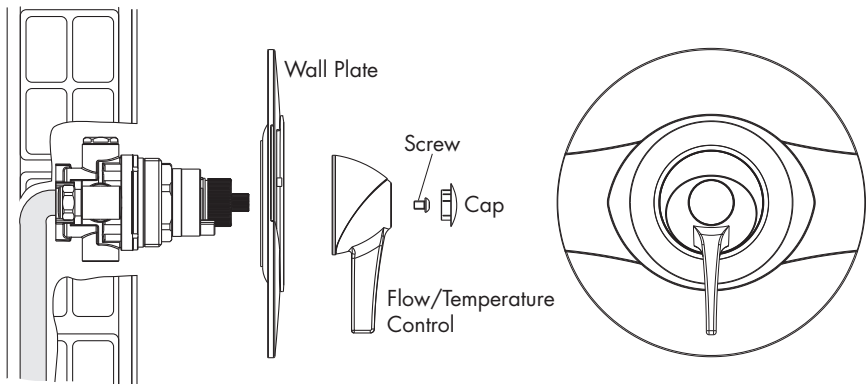

Calibration

The factory outlet temperature setting of 41°C can be altered to suit site conditions.

WARNING: Care should be taken when altering the setting as incorrect calibration can cause injury.

- Remove the indice (1) from the front of the shower valve.
- Remove the retaining screw (2) and handle (3).
- The temperature stop rings (4) are used to control the temperature. Ring A controls the hot and ring B controls the cold water.
- Remove both rings (4) from the cartridge and set the mixed water to the required temperature, maximum 41°C.
- Temporarily re-fit the handle (3) and using a digital thermometer it is possible to increase or reduce the mixed water outlet temperature until 41°C is re-established, by slowly rotating the handle.
- The temperature can be measured from mixed water outlet on the exposed valve and from the wall elbow or shower head outlet with the shower head removed for fully concealed installations.
- When the required temperature is achieved replace the two stop rings (4) on the splined spindle. The rings are used to set the temperature limits of the shower when in use.
- Re-assemble the handle (3), secure with the retaining screw (2) and re-fit the indice (1).

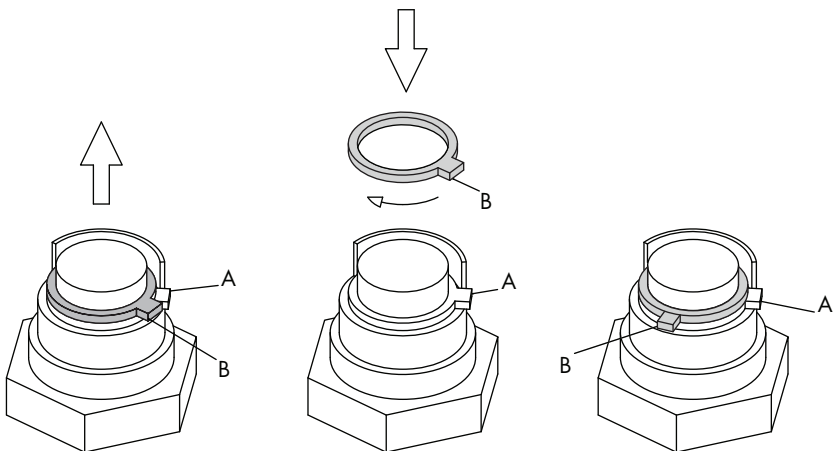

Cartridge Replacement

- Isolate both the hot and cold water supplies
- Remove the indice (1), retaining screw (2), handle (3) and the two stop rings (4).
- Using a suitable socket unscrew the cartridge (3).
- Replace with a new cartridge.
- The shower valve must be re-calibrated after fitting the new cartridge following the procedure above.
- Re-fit the handle, retaining screw and indice.

Calibration and Cartridge Replacement

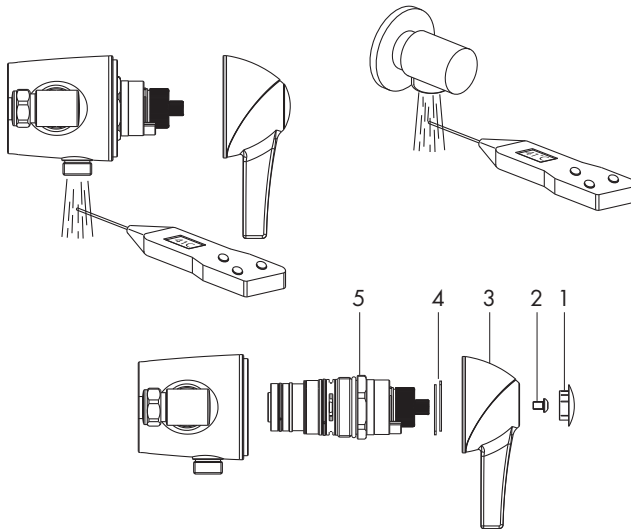

Aftercare

Inta shower mixing valves have a high quality finish and should be treated with care.

An occasional wipe with a mild washing-up liquid on a soft damp cloth followed by a thorough rinsing is all that is required.

The nozzles in the hand set should be cleaned periodically to remove any build up of debris or deposits which may affect the performance of the shower.

Do not use an **abrasive** or **chemical household cleaner** as this may **cause damage**.

Vista **TMV3** Thermostatic Shower Valve

Introduction

The Vista thermostatic shower mixing valve has been specifically designed and manufactured to meet the requirements of BS 7942: 2000 and NHS D08. The valve has been independently tested and approved as a TYPE 3 valve under the TMV3 scheme.

Technical Specification / Conditions for use **TMV3** Valves

Outlet Temperature Adjustment Range	30°C to 50°C
Temperature Stability	±2°C
Maximum Hot Inlet Temperature	85°C
Inlet Temperature Range	52°C to 65°C : Hot Supply 5°C to 20°C : Cold Supply
Max. Working Pressure	10 bar : Static
Min. Working Pressure	0.2 bar : Dynamic
DO8 Working Pressure Range	0.2 to 1.0 bar : Low Pressure 1.0 to 5.0 bar : High Pressure
Min Temp Differential (Mix to Hot) for Fail-Safe	10°C
Max. Pressure Inlet Differential	5 : 1
Max. Flow Rate @ 1 bar Differential	Ø15mm 1500 l/h (25 l/m) Ø22mm 1700 l/h (28.3 l/m)

NOTE: Valves operating outside these conditions cannot be guaranteed by the Scheme to operate as Type 3 valves.

Approvals

TMV3 Scheme Approval Number: Details Available on Request

WRAS Scheme Approval Number: Details Available on Request

Fail Safe Function

Vista shower valves are designed to stop the mixed water flow in the event of either the hot or cold water supply failing when installed in accordance with these instructions. To ensure full closure of the mixed water flow the minimum temperature differential between the hot water inlet to the valve and the mixed water outlet **MUST be at least 10°C**.

installation guide **TMV3**

Dimensions

See page 6 for the exposed shower valve and page 7 for the concealed shower valve.

Temperature Setting

Ensure that the shower valve is commissioned under normal system conditions. The valve **MUST** be commissioned to suit site conditions and the desired outlet temperature set by the installer;

- i. With normal supply conditions established and the hot and cold water supplies running, open the shower valve to its maximum temperature and leave running.
- ii. Remove the indice, retaining screw and handle.
- iii. The temperature stop rings are used to control the temperature, ring A the hot and B the cold water, see diagram on page 12.
- iv. Remove both rings from the cartridge and set the mixed water to the required temperature, maximum 41°C.
- v. Temporarily refit the handle and using a digital thermometer it is possible to increase or reduce the mixed water outlet temperature until 41°C is re-established, by slowly rotating the handle.
- vi. The stop rings are used to set the temperature limits of the shower when in use. When the required temperature is achieved replace the two stop rings on the splined spindle.

Application

The Vista thermostatic shower mixing valve has been independently tested by Buildcert Limited and certified as meeting the requirements of the NHS D08 specification under the TMV3 Scheme as being suitable for use on the following designations;

Shower **HP and LP**

Installation

IMPORTANT - The following instructions must be read prior to the installation of any Inta shower valve. The installer should also be aware of their responsibility and duty of care to ensure that all aspects of the installation comply with all current regulations and legislation.

Flushing through water systems using certain chemicals may wholly or partially remove the lubricant from the internal workings of the valve, which may adversely affect its performance. We recommend that following a flushing of the system with chemicals, valves are checked for correct operation.

- 1 It is essential that before installing a Vista shower valve to ensure that the supply conditions of the system, to which the valve is intended to be fitted, are checked to confirm compliance with the parameters as quoted within the Technical Specification and conditions on which the approval is granted i.e. verify supply temperatures, supply pressures, risk assessment.

Installation

- 2 Consideration must be made for the possibility of multiple / simultaneous demands being made on the supply system whilst the Vista shower valve is in use, all practical precautions must be made to ensure that the valve is not affected. Failure to make provision within the pipe sizing etc. will affect the performance of the valves.
- 3 The supply system to which the Vista shower valve is to be installed into must be thoroughly flushed and cleaned to remove any debris, which may have accumulated during the installation. Failure to remove any debris will affect the performance and the manufacturer's warranty of the product. Independent filters / check valves and isolation valves must be fitted in conjunction with the shower valve, as close as practically possible to the water supply inlets of the Vista thermostatic valve. In areas that are subject to aggressive water, provision must be made to treat the water supply prior to the supply entering any product.
- 4 The maximum flow rate of the valve will only be achieved when the supply conditions are achieved as quoted within the Technical Specification, with a flow condition under 1 bar differential pressure.
- 5 The Vista shower valve has been designed for horizontal installation either exposed surface mounted or concealed within wall or supply duct. It is essential that the access to the valve is not obstructed for any future maintenance that may be required to the valve or associated fittings.
- 6 The hot and cold water supplies must be connected to the valve strictly in accordance with the indications on the body of the valve i.e. hot water supply to the hot port of the valve.
- 8 In a situation where one or both of the water supplies are excessive, it is possible to fit a pressure reducing valve or the 6 l/m flow regulator to reduce the pressure(s) to within the limits as quoted previously.
- 9 Any thermostatic shower mixing valve must be fitted with a back flow prevention device, such as check valves to prevent the cross contamination of supplies. The Vista shower valve is complete with integral insert check valves and strainers in the inlet elbows. However if required, additional WRAS approved backflow prevention devices should be positioned as close as practically possible to the water supply inlets of the Vista thermostatic shower valve.
- 10 Y Pattern strainers and full-bore isolation valves must be installed in conjunction with the Vista fail-safe thermostatic shower valve as close as is practically possible to the location of the valve.
- 11 It is essential that the Vista fail-safe thermostatic shower valve should not be installed in situations where there is a possibility of the valve being deprived of water or where demands for water are greater than the actual stored supplies.
- 12 To ensure that the performance levels of the Vista thermostatic shower valve is maintained (in the event of cold water failure), the temperature of the hot water supply at the point of entry to the valves must be a minimum of 10°C above the commissioned mixed water discharge temperature.

Installation

- 13 The Vista fail-safe thermostatic shower valve must not be subject to any extreme temperature variations either during the installation or under normal operating conditions.

Commissioning

IMPORTANT - The following instructions must be read and understood prior to the commissioning the Vista fail-safe thermostatic shower valves. If under any circumstances there are aspects to the installation / system which do not comply with the specification laid down, the valve **MUST NOT** be put into operation until the system / installation complies with our specification. However if all these conditions are met, proceed to set the temperature as follows;

- 1 Ensure that the system is thoroughly cleaned and free from any debris prior to the commissioning the Vista fail-safe thermostatic shower valve.
- 2 Commissioning the temperatures must be carried out using a suitably calibrated thermometer preferably a digital thermometer.
- 3 In the absence of other temperatures being specified, we recommend the outlet temperature quoted in Table 1 are used.

Table 1

Application	Recommended Set Mixed Water Temp.
Shower	41°C

- 4 Each shower valve must be commissioned taking into consideration any fluctuations, which may occur within the system due to simultaneous demands. It is advisable that any outlets which are connected to the same supply as the shower valve are opened during the setting of the mixed water temperature. During commissioning it is advisable to ensure that the water temperatures are established before any attempt to commission.
- 5 Once the supply temperatures are stable and the normal operating conditions are established, the valve can be commissioned. The temperature setting can be adjusted by removing the handle from the valve body and re-positioning the temperature stop rings. We suggest that the following sequence is followed when commissioning the valve:
 - 5.1 Set the mixed water temperature to the required temperature.
 - 5.2 Measure and record the temperature of the hot and cold water supplies at the connection to the valve.
 - 5.3 Measure and record the temperature of the water discharging from the shower valve.
 - 5.4 Isolate the cold water supply to the valve and monitor the mixed water temperature.
 - 5.5 Measure and record the maximum mixed water temperature and the final temperature. The final temperature found during the test should not exceed the value quoted in Table 2.
 - 5.6 Record all the equipment used during the commissioning.

Commissioning

Table 2

Application	Maximum Set Mixed Water Temp.
Shower	43°C

- 6 Once the desired temperature is established replace and re-position the temperature stop rings, refit the handle.
- 7 Ensure that the application, in which the shower valve will be used, is appropriate for the approved designation. The above information must be recorded and updated on every occasion when any work is carried out on the valve.

Maintenance

To ensure that the Vista shower valve maintains a high level of protection, we advise the following in service testing is conducted (the same equipment used to commission the valve initially must be used in the following tasks).

- 1 After a period of between 6 and 8 weeks from commissioning carry out the following;
 - 1.1 Record the temperature of the hot and cold water supplies.
 - 1.2 Record the temperature of the mixed water from the shower valve.
- 2 If the mixed water temperature has changed significantly from the previous test results (e.g. >1°K), record the change and before resetting the mixed water temperature check that:
 - 2.1 All the strainers are clean.
 - 2.2 All the check valves are in good working order.
 - 2.3 The isolation valves are fully open.
- 3 If the mixed water temperatures are acceptable, carry out the following:
 - 3.1 Record the temperature of the hot and cold water supplies.
 - 3.2 Record the temperature of the mixed water from the shower valve.
 - 3.3 Isolate the cold water supply to the mixing valve and monitor the mixed water temperature.
 - 3.4 Record the maximum temperature achieved as a result of (3.3) and the final temperature (the final temperature should not exceed the values quoted in table 2)
 - 3.6 Record the equipment used during these tests.
- 4 If the mixed water temperature is greater than the values quoted in table 2 or the maximum temperature exceeds the corresponding values from previous test results by more than 2°K, the valve must be serviced.

Maintenance

- 5 After a period of between 12 to 15 weeks from commissioning, carry out the sequence of tests as described in Maintenance sections 1, 2, 3 and 4.
- 6 Dependant upon the results obtained from the first two series of tests; there are a number of possible outcomes:
 - 6.1 If no significant change in the mixed water temperatures (e.g. $\leq 1^{\circ}\text{K}$) is recorded between commissioning and Maintenance sections 1 or between commissioning and Maintenance sections 5, the next in service testing should be carried out at a period of 24 to 28 weeks after initial commissioning.
 - 6.2 If a small change (e.g. 1 to 2°K) in the mixed water temperature is recorded in only one of these periods, necessitating adjustment of the mixed water temperature, then the next in service can be deferred to 24 to 28 weeks after commissioning.
 - 6.3 If small changes (e.g. 1 to 2°K) in the mixed water temperature are recorded in both of these periods, necessitating adjustment of the mixed water temperature, then the next in service test can be deferred to 18 to 21 weeks after commissioning.
 - 6.4 If significant changes (e.g. $> 2^{\circ}\text{K}$) in the mixed water temperature are recorded in both of these periods necessitating service work, then the next in service test should be carried out at 18 to 21 weeks after commissioning.
- 7 The general principle to be observed after the first 2 or 3 in-service tests is that the intervals for future tests should be set to those which previous tests have shown can be achieved with no more than a small change in mixed water temperature.
- 8 In all areas periodic maintenance of the valve and associated fittings i.e. strainers, check valves will ensure optimum performance levels are maintained.
- 9 The inlet strainers on both the hot and cold water supplies can be removed for cleaning by unscrewing the inlet union nuts and carefully pulling apart the connecting pipework.
- 10 The built in check valves can be accessed to ensure freedom and correct seating.

Spares

A full range of spares are available for this product from Inta.

PLEASE NOTE: Only genuine spares should be used.

Problem Solving

The following details are supplied for on site queries, should you require any further assistance our Technical Department can be contacted directly on 01889 272199.

1 Hot water at other outlets

- i. Operation of the insert check valves is hindered, check the valve is seated correctly.
- ii. Check Valves not fitted.
- iii. Unbalanced hot/cold supply pressure.

2 Fluctuating mixed water temperature

- i. Erratic supply temperatures at the inlets of the valve.
- ii. Starvation of the water supplied at the inlets of the valve.
- iii. Incorrect commissioning of the valve.

3 Erratic flow

- i. Insufficient water supplies.
- ii. Fluctuations in the supply pressures/temperatures.
- iii. Adverse effect created by other draw off points on the system.

4 No flow/reduced flow from shower

- i. In line filters are blocked.
- ii. Insufficient supply pressure.
- iii. Debris obstructing valve operation.
- iv. Valve requires servicing (Servicing kits available from your local stockist).

5 Valve does not fail safe when tested

- i. Installation not in accordance with our recommendations.
- ii. The minimum temperature differential not achieved.
- iii. Internal mechanism hindered by debris.

Full and detailed instructions are supplied with service kits and are available on request.

Vista **TMV2** Thermostatic Shower Valve

The following information is required when the thermostatic mixing valve is used in a TMV2 Applications under the requirements of BS EN 1111:1999 "Sanitary tapware – Thermostatic Mixing Valve (PN 10) – General Technical Specification" and BS EN 1287:1999 "Sanitary tapware. Low pressure thermostatic mixing valves. General technical specifications".

Introduction

The thermostatic shower valve has been specifically designed and manufactured to meet the requirements of BS EN 1111:1999 and BS EN 1287:1999 TMV2 Type Scheme. The valve has been independently tested and approved as a TYPE 2 valve under the BuildCert TMV2 scheme by the WRc - NSF Testing & Evaluation Center.

Supply Conditions

The supply conditions to the Thermostatic Mixing Valve must comply with the following;

Conditions	High Pressure BS EN 1111	Low Pressure BS EN 1287
Maximum Static Pressure	10 bar	10 bar
Flow Pressure, Hot & Cold	0.5 to 5 bar	0.1 - 1 bar
Hot Supply Temperature	55 to 65°C	55 to 65°C
Cold Supply Temperature	≤ 25°C	≤ 25°C
Temperature Stability	± 2°C	± 2°C
Min Temp Differential (Mix to Hot) for fail-safe	10°C	10°C
Max. Pressure Inlet Differential	5:1	5:1

Note: Valves operating outside these conditions cannot be guaranteed by the Scheme to operate as type 2 valves.

Approvals

Buildcert Scheme Approval Number:

Details Available on Request

WRAS Scheme Approval Number:

Details Available on Request

Application

The thermostatic shower mixer has been independently tested by WRc - NSF and certified as meeting the requirements of the BS EN 1111:1999 and BS EN 1287:1999 under the TMV2 Scheme as being suitable for use on the following designations.

Shower

HP and LP

installation guide **TMV2**

Recommended Outlet temperatures

The BuildCert TMV scheme recommends the following set maximum mixed water outlet temperature for use in all premises:

Application	Recommended Hot Water Temperature
Shower	41°C

The mixed water temperature must never exceed 43°C.

The maximum mixed water temperature can be 2 °C above the recommended maximum set outlet temperature.

Note: 43°C is the maximum mixed water temperature from a shower mixer. The maximum temperature takes account of the allowable tolerances inherent in thermostatic shower mixers and temperature losses.

It is not a safe bathing Temperature for adults or children.

The British Burns Association recommends 37 to 37.5°C as a comfortable bathing temperature for children. In premises covered by the Care Standard Act 2000, the maximum mixed water outlet temperature is 43°C.

Installation

Important: - The following instructions must be read prior to the installation of the thermostatic shower valve. The installer of the thermostatic shower valve must comply with the requirements of the Water supply (Water Fittings) Regulations 1999 and also be aware of their responsibility and duty of care to ensure that all aspects of the installation comply with the regulations.

It has been brought to our attention that flushing water systems using certain chemicals may wholly or partially remove the lubricant from the internal workings of the valve, which may adversely affect its performance. We recommend that following flushing the system with chemicals; valves are checked for correct operation.

1. It is essential that before installing any thermostatic shower valve to ensure that the supply conditions of the system to which the valve is intended to be fitted are checked to confirm compliance with the parameters as quoted within the technical specification and conditions on which the approval is granted i.e. verify supply temperatures, supply pressures, risk assessment.
2. Consideration must be made for the possibility of multiple / simultaneous demands being made on the supply system whilst the thermostatic shower valve is in use, all practical precautions must be made to ensure that the valve is not affected. Failure to make provision within the pipe sizing etc. will affect the performance of the shower valve.

Installation

3. The supply to which the thermostatic shower valve is to be installed must be thoroughly flushed and cleaned to remove any debris, which may have accumulated during the installation. Failure to remove any debris will affect the performance and the manufacturer's warranty of the product. In areas that are subject to aggressive water, provision must be made to treat the supplies prior to the supplies entering the shower valve.
4. The thermostatic shower valve has been designed for horizontal installation and surface mounting.
5. The thermostatic shower valve will be installed in such a position that maintenance of it's components, associated valves and the commissioning and testing of the shower valve can be undertaken.
6. The hot and cold water supplies must be connected to the valve strictly in accordance with the indications on the body of the valve i.e. hot water supply to the hot port of the valve.
7. In a situation where one or both of the water supplies are excessive, it is recommended to fit a Pressure Reducing Valve to reduce the pressure(s) to within the limits as quoted previously.
8. Any thermostatic shower valve must be fitted with a back flow prevention device, such as check valves to prevent the cross contamination of supplies. The thermostatic shower valve is supplied complete with integral insert check valves and strainers.
9. Isolation valves in an accessible position are required as close as is practicable to the water supply inlets of the thermostatic shower valve.
10. The fitting of strainers is recommended as close as is practicable to the water supply inlets of the thermostatic shower valve.
11. It is essential that the fail safe thermostatic shower valve should not be installed in situations where there is a possibility of the valve being deprived of water or where demands for water are greater than the actual stored supplies.
12. To ensure that the performance levels of the thermostatic shower valve are maintained (in the event of cold water failure), the temperature of the hot water supply at the point of entry to the thermostatic shower valve must be a minimum of 10°C above the commissioned mixed water discharge temperature.
13. The fail-safe thermostatic shower valve must not be subject to any extreme temperature variations either during the installation or under normal operating conditions.

Commissioning

Important: - The following instructions must be read and understood prior to commissioning the thermostatic shower valve. If under any circumstances there are aspects to the installation / system which do not comply with the specification laid down, the valve **MUST NOT** be put into operation until the system / installation complies with the specification. However if all these conditions are met, proceed to set the temperature as follows;

1. Ensure that the system is thoroughly cleaned and free from any debris prior to commissioning the thermostatic shower valve.
2. Commissioning the temperatures must be carried out using a suitably calibrated thermometer, preferably a digital thermometer. The sensing part of the thermometer probe must be fully submerged in the water when testing.
3. The valve must be commissioned taking into consideration any fluctuations, which may occur within the system due to simultaneous demands. It is advisable that any outlets which are connected to the same supply as the shower valve are open during setting of the mixed water temperature. It is advisable to ensure that the water temperatures are established before any attempt to commission.
4. Once the supply temperatures are stable and the normal operating conditions are established, the shower valve can be commissioned. The following sequence should be followed when commissioning the valve;
 - 4.1 The first step in commissioning a thermostatic shower valve is to check the following:
 - The designation of the thermostatic shower valve matches the application
 - The supply pressures are within the valve's operating range.
 - The supply temperatures are within the valve's operating range.
 - Isolating valves (and 'Y' strainers preferred) are provided.
 - 4.2 If all these conditions are met, proceed to set the temperature following the procedure described earlier in the Calibration section.
 - 4.3 Measure and record the temperature of the hot and cold water supplies at the connection to the valve.
 - 4.4 Measure and record the temperature of the water discharging from the valve.
 - 4.5 Isolate the cold water supply to the valve and monitor the mixed water temperature.
 - 4.6 Measure and record the maximum mixed water temperature and the final temperature. The final temperature found during the test should not exceed the values quoted.
 - 4.7 Record all the equipment used during the commissioning.
 - 4.8 The mixed water temperature at the terminal fitting must never exceed 2°C above the set temperature.

Commissioning

5. If the mixed water temperature exceeds the recommended temperature of 41°C by 2°C or does not reach 41°C the shower valve can be adjusted as follows:
 - 5.1 With normal supply conditions established and the hot and cold water supplies running, open the shower valve to its maximum temperature and leave running.
 - 5.2 Remove the indice, retaining screw and handle.
 - 5.3 The temperature stop rings are used to control the temperature, ring A the hot and B the cold water, see diagram on page 12.
 - 5.4 Remove both rings from the cartridge and set the mixed water to the required temperature, maximum 41°C.
 - 5.5 Temporarily refit the handle and using a digital thermometer it is possible to increase or reduce the mixed water outlet temperature until 41°C is re-established, by slowly rotating the handle.
 - 5.6 The stop rings are used to set the temperature limits of the shower when in use. When the required temperature is achieved replace the two stop rings on the splined spindle.
6. The above information must be recorded and updated on every occasion when any work is carried out on the valve.

In Service Testing

It is a requirement that all TMV2 approved valves shall be verified against the original set temperature results once a year. When commissioning / testing is due the following performance checks shall be carried out.

1. Measure the mixed water temperature at the outlet.
2. Carry out the cold water supply isolation test by isolating the cold water supply, wait for five seconds if water is still flowing check that the temperature is below 43°C.
3. If there is no significant change to the set outlet temperature ($\pm 2^\circ\text{C}$ or less from the original settings) and the fail-safe shut off is functioning, then the valve is working correctly and no further service work is required.

Notes:

- If there is a residual flow during the commissioning or the annual verification (cold water supply isolation test), then this is acceptable providing the temperature of the water seeping from the valve is no more than 2°C above the designated maximum mixed water outlet temperature setting of the valve.
- Temperature readings should be taken at the normal flow rate after allowing for the system to stabilise.
- The sensing part of the thermometer probe must be fully submerged in the water to be tested.
- Any thermostatic shower that has been adjusted or serviced must be re-commissioned and re-tested in accordance with the manufacturers' instructions

Please leave this Manual for the User

inta

Intatec Ltd

Airfield Industrial Estate
Hixon
Staffordshire
ST18 0PF

Tel: **01889 272 180**

Fax: **01889 272 181**

email: **sales@intatec.co.uk**

web: **www.intatec.co.uk**