

# BRISTAN

## Kingsbury Monobloc Sink Mixer

### Installation Instructions & User Guide



Please keep these instructions for future reference and request of replacement parts

<b>Contents</b>	<b>Page</b>
1. Introduction	03
2. Safety Note	03
3. Specification	03
4. Installation	04
5. Cleaning & Maintenance	05
6. Notes	06
7. Bristan Guarantee	07

## 1. Introduction

Thank you for choosing Bristan, the UK's leading taps and showers expert. We have designed this product with your enjoyment in mind. To ensure that it works to its full potential, it needs to be fitted correctly. These fitting instructions have been created to give you all of the information you need and, if you need any further help, please do not hesitate to give us a call on 0844 701 6273.

## 2. Safety Note

Please read these instruction thoroughly and retain for future use. All products manufactured and supplied by Bristan are safe provided they are installed correctly, used correctly and receive regular maintenance in accordance with these instructions.

These fittings need to be installed in accordance with and meet the requirements of the Water Supply (Water Fittings) Regulations 1999 and Scottish Byelaws 2004.

## 3. Specification

	Min.	Max.
Operating pressure range (bar)	0.2	8.0

NOTE:- Nominally equal (balanced) inlet supply pressures are recommended for optimum performance.

Designed to comply with BS EN 200 for single taps/ combination taps for water systems of type 1 and 2 general technical specifications and to be used within systems designed to BS 6700.

BS 6700 recommends the temperature of stored water should never exceed 65°C. A stored water temperature of 60°C is considered sufficient to meet all nominal requirements and will minimise the build up of lime scale in hard water areas.

This mixer is suitable for use at all supply pressures. If the fitting is installed at low pressure (tank fed), then the minimum height from the outlet of the nozzle to the underside of the cold water tank should be at least at least 2 metres to ensure adequate performance.

This mixer should be installed in compliance with the Water regulations, where the supplies are unbalanced i.e hot water from a cylinder tank and cold from the mains. Approved check valves must be fitted in the supply pipes, for further details contact your Local Water Authority.

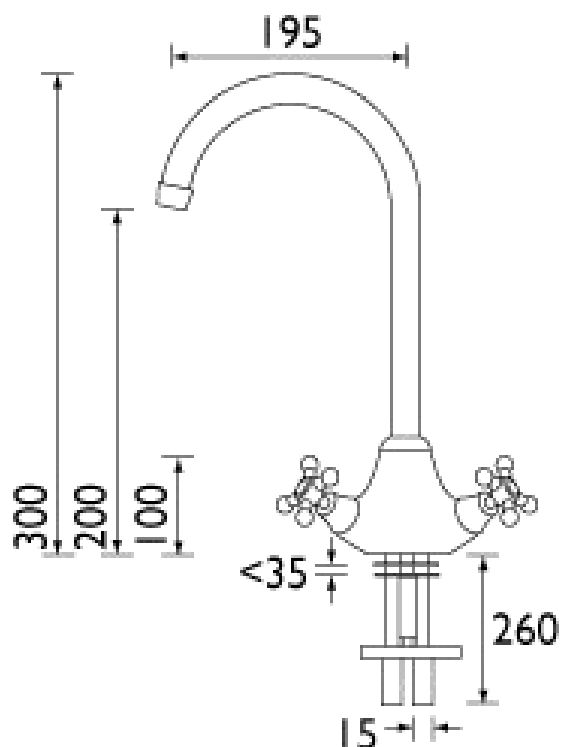

## 4. Installation

1. Identify all the parts are present and correct before commencing installation.
2. Fit the mixer to the sink using the C plate fixing kit. The full rubber washer goes between the fitting and the sink, the C shaped rubber and metal washer on the underside of the sink.
3. Fit the flexible inlet connections by HAND ONLY (DO NOT OVERTIGHTEN) to the fitting and connect the hot and cold supplies.
3. Fully open both valves, letting them run for a few minutes to flush the system through.
5. Check all joints and connections for leaks
6. See page 6 for aftercare instructions.

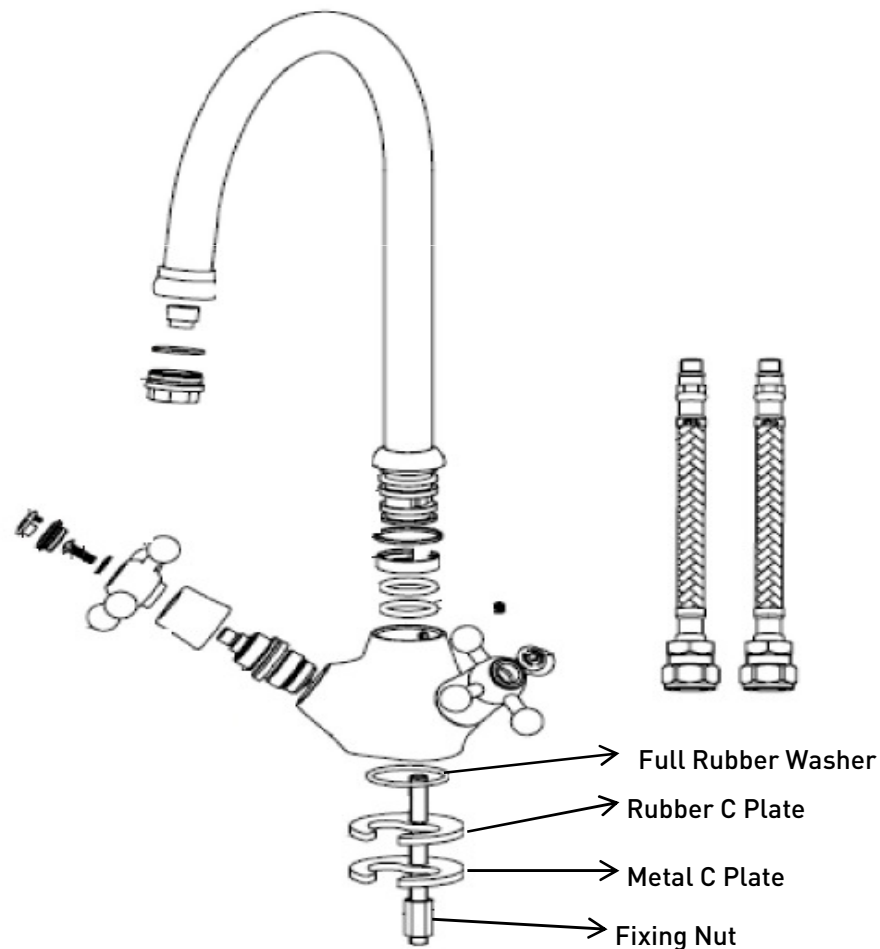

## 5. Cleaning & Maintenance

Your fitting has a high quality finish and should be treated with care to preserve the visible surfaces.

All finishes will wear if not cleaned correctly. The only safe way to clean your product is to wipe with a soft damp cloth. Stains can be removed using washing up liquid. All bathroom cleaning product (powders and liquids) will damage the surface of your fitting, even the non-scratch cleaners.

NOTE:- Never use abrasive detergents or disinfectants or those containing alcohol, hydrochloric or phosphoric acid.

We advise that your fitting is regularly serviced, particularly in hard water areas.

If the fitting begins to drip:

1. Turn off both water supplies.
2. Remove fitting head and valve.
3. Carefully clean the seating and rubber washer.
4. Replace the valve and then turn on the water supplies.
5. If problem persists contact our helpline quoting the product code overleaf.

**Bristan recommend E-Cloth for cleaning all of our bathroom & kitchen products. Using just water, E-cloth gives a smear free, deep clean by breaking up and holding dirt, which normal cloths leave behind. Order through your Bristan stockist.**

**(ORDER CODE: E-CLOTH)**



## 6. Notes

Please use this space to add any comments you or your installer may have regarding the plumbing system/installation of this product.



**Guarantee**

## 7. Bristan Guarantee

Bristan offers solid guarantees to provide you with complete peace of mind.

### Taps and Mixers

5 year parts and 1 year labour\*. Gold, painted and special finishes 3 years parts only.

All subject to proof of purchase.

### Mixer Shower Valves

5 year parts. 5 year labour\* (subject to registration), or 1 year with proof of purchase.

Gold, painted and special finishes 3 years parts only.

### Pumps and Power Showers

2 year parts. 1 year labour\* (subject to registration).

### Electric Showers/Instantaneous Water Heaters

2 year parts. 1 year labour\* (subject to registration).

### Accessories

5 year parts only. Includes bathrooms accessories, shower accessories (e.g. hoses, handsets and poles), wastes, WC levers and light pulls. Gold, painted and special finishes 3 years parts only.

### Sanitaryware

5 year parts only. Subject to proof of purchase.

### Shower Enclosures and Shower Trays

10 year parts (subject to registration), or 2 years with proof of purchase. 1 year labour\* (subject to registration), or 1 year with proof of purchase.

### Heated Towel Rails

5 year parts only. Gold, painted and special finishes 3 years parts only. All subject to proof of purchase.

\*Labour provided by an approved Bristan engineer. Guarantee only applies to products with a manufacturing fault. A deferred payment will be necessary in order to secure any visits by our engineers which will be charged if the problem is found **not** to be a manufacturing fault. If the fault is found to be down to a manufacturing error, the payment will be released and not charged.

This guarantee applies to products purchased within the United Kingdom or Republic of Ireland, but does not apply to products used commercially.

The guarantee is only available to original purchasers who have proof of purchase.

The installation must allow ready access to all products for the purpose of inspection, maintenance or replacement.

Any part found to be defective during the above guarantee period will be replaced without charge, providing that the product has been installed in accordance with the instructions, used as intended, and regularly serviced.

Servicing should be carried out at regular intervals of no more than 12 months and more frequently in hard water areas (heavy lime scale) areas.

In the unlikely event that any problems are encountered with the product's performance on installation, you must obtain guidance/authorisation from our Customer Service Department, and be able to supply proof and date of purchase, before any remedial action is taken.

The guarantee excludes general wear and tear and damage caused by accident, misuse or neglect, and does not cover the following:

- Components that are subject to general wear and tear such as filters, seals, 'O' rings and washers etc.
- Damage caused by faulty installation
- Damage caused by lime scale or any waterborne debris
- Damage caused by inappropriate cleaning products (see user instructions)
- Damage caused by the use of non-Bristan parts
- The product being used for a purpose other than intended by the manufacturer.

In the interests of continuous product improvement Bristan reserves the right to alter specification as necessary.

If your product is out of its guarantee period, or you would like to extend the guarantee, then please see our [extended warranty offer](#).

# BRISTAN

This booklet covers product code  
KG SNK C, KG SNK G

**Helpline**

**0844 701 6273**

Bristan Group Limited

Birch Coppice Business Park, Dordon, Tamworth, Staffordshire B78 1SG

A Masco Company

Website: [www.bristan.com](http://www.bristan.com)

Telephone: 0844 7016 274      Facsimile: 0844 701 6275

Email: [enquire@bristan.com](mailto:enquire@bristan.com)