

**Glow•worm**  
The energy you need

# Easicom<sub>2</sub>

Quality, Reliability, Flexibility



# Easicom<sub>2</sub>

## Quality, Reliability, Flexibility

The Easicom<sub>2</sub> from Glow-worm is a high efficiency A-rated boiler which comes with a choice of outputs and warranties to suit.

Designed with a high quality and powerful aluminium heat exchanger, Easicom<sub>2</sub> has leading features, a bright easy to read LCD display and comes with a 3 year warranty as standard, with the option to extend\*.

The Easicom<sub>2</sub> is delivered as a boiler, flue and analogue timer package and is supported by a UK brand you can trust with industry leading service, support and an award winning loyalty programme.



\*When registered through Club Energy. Extended warranties also available through Club Energy.



### Exclusive Glow-worm boiler

Developed exclusively for independent merchant branches to meet installer requirements and deliver great margin.



### High quality automotive grade aluminium heat exchanger

Designed to last longer, easy to maintain, ultra quiet and reduces customers' energy bills.



### Modern bright LCD display

Excellent clarity boiler display wherever it is installed making it easy to change and confirm settings.



### High Efficiency modulating Grundfos pump

Lower running costs as pump adapts to actual heating and hot water demand.



### ErP A rated

New high efficiency boiler range with A rated label to meet ErP legislation. Comes with online labelling tool for installers.



### Compatible with full range of Glow-worm controls

Wide range of controls from the inbuilt analogue timer to the MiGo app based control.



### Supported by **clubenergy**

Full suite of support tools including instant Gas Safe notifications, access to extended warranties and the Plumbing Toolbox app making installation and administration easier.



### Guaranteed for 3 years when registered through Club Energy

3 year parts & labour guarantee comes as standard with an option to extend.



Guaranteed 3 year warranty when registered through Club Energy, with the option to extend



ErP A rated



Ultra quiet operation



Easy to install and service



### Product Features & Benefits

- Combi boiler range with the choice of 24 or 28 kW outputs
- Modern bright LCD display with easy to use interface
- Compact, smart design to suit modern homes
- High quality automotive grade aluminium heat exchanger providing excellent performance
- High efficiency, A rated boiler for ErP energy labelling to reduce energy bills
- Grundfos modulating pump for reduced energy use
- Compatible with full range of Glow-worm controls, flues and accessories
- Package includes boiler, standard flue and inbuilt analogue timer
- 3 year parts and labour guarantee with an extended warranty option available through Club Energy
- Telescopic flue option available
- Ø60/100 and Ø80/125 flue options available
- Wide range of accessories available including spacing frame and pipe cover plate
- Plume Management kit compatible

## Easicom<sub>2</sub> combi boiler

Easicom<sub>2</sub> is a highly efficient combi boiler with a choice of 24 or 28 kW outputs for instant hot water and heating. Easicom<sub>2</sub> comes with a simple inbuilt analogue timer and is also compatible with the full range of Glow-worm controls including the popular Climapro<sub>2</sub> RF wireless programmer, making it easy to set the heating programme required and run in the most efficient way to meet heating & hot water demands.

Developed using automotive grade aluminium the Easicom<sub>2</sub> heat exchanger is a high quality, high efficiency product that makes the boiler not only light to install but also easy to maintain. This means lower costs, more reliability and the Easicom<sub>2</sub> is backed by a 3 year standard guarantee with an extended warranty option available from your Glow-worm Club Energy installer.



Easicom <sub>2</sub> combi boiler	24kW	28kW
Casing dimensions (h w d)	740mm x 418mm x 300mm	740mm x 418mm x 300mm
DHW flow rate storage/combi (l/min, 35C rise)	10	11.7
60/100 Flue Length		
Horizontal	9m	9m
Vertical	9m	9m
SEDBUK 2009 annual efficiency (%)	89.3	89.3
ErP Rating Heating	A	A
ErP Rating DHW	A	A

### Accessories

Easicom<sub>2</sub> features an inbuilt analogue timer as standard. In addition it also offers a great choice of intelligent controls and accessories to deliver the most efficient heating system for your customers.



**MiGo**  
WiFi connected, app based control



**Climapro<sub>2</sub> RF**  
Wireless programmable room thermostat



**Climapro<sub>1</sub>**  
Programmable room thermostat



**Climastat**  
Easy to use digital heating thermostat

# Technical specifications

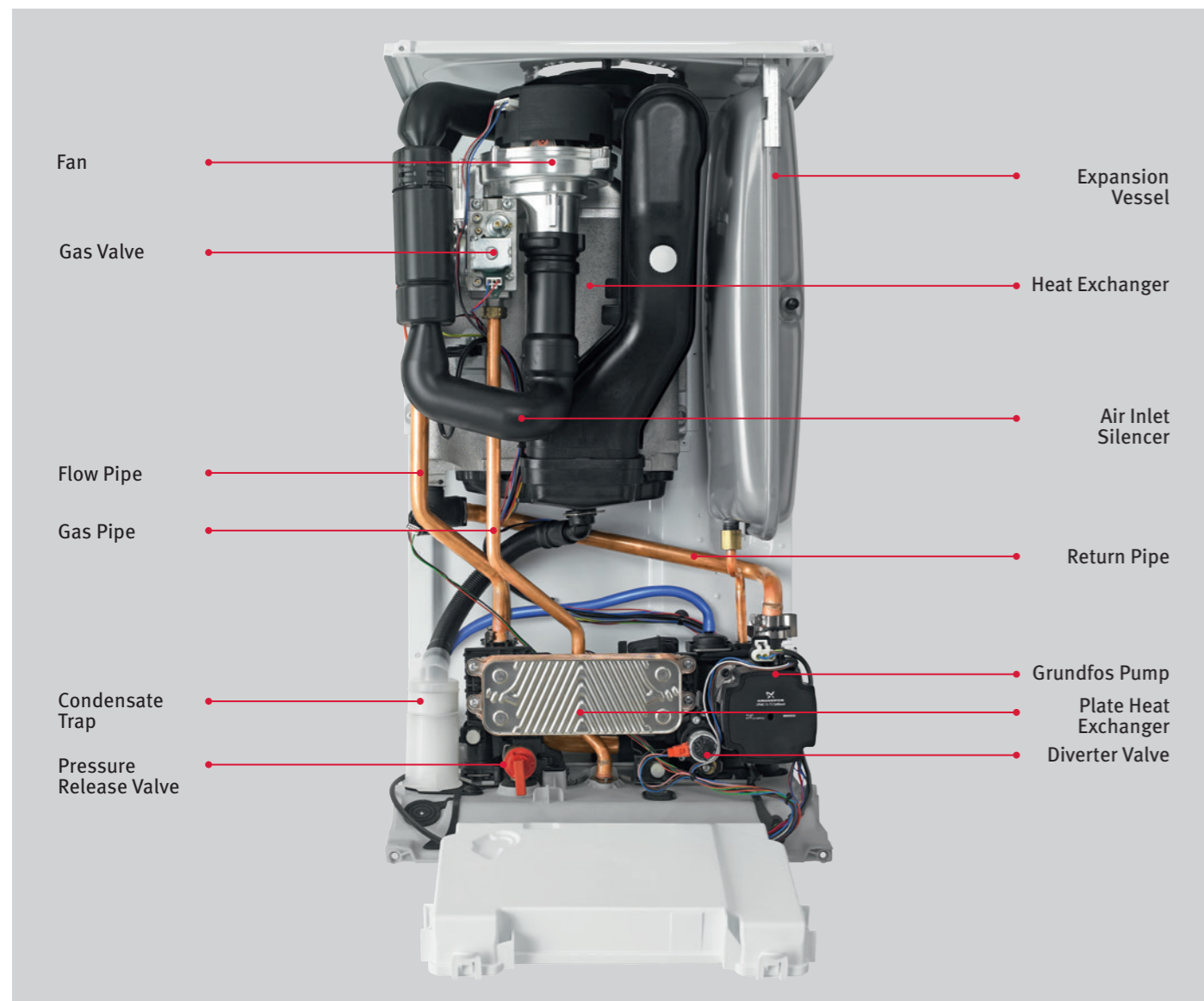

# Technical specifications



Easicom <sub>2</sub> combi boilers	24c	28c
Casing dimensions (h w d) (mm)	740 x 418 x 300	740 x 418 x 300
Weight (lift) (kg)	32	33
<b>Performance</b>		
CH output (kW) Min/Max	5/20.4	6/24.7
DHW output (kW) CH output (kW) Min/Max	5/24	6/28
DHW flow rate storage/combi (l/min. 35°C rise)	10	11.7
SEDBUK rating 2009	89.3	89.3
NOx class 5 (natural gas)	Yes	Yes
LPG compatible	No	No
ErP Rating Heating	A	A
ErP Rating DHW	A	A
<b>Construction</b>		
Heat exchanger material	Aluminium	Aluminium
Burner type	Pre-mixed	Pre-mixed
Fully modulating	Yes	Yes
DHW plate heat exchanger	Yes	Yes
Integrated hydrobloc	Yes	Yes
<b>Installation</b>		
Suitable for sealed systems	Yes	Yes
Inbuilt adjustable system bypass	Yes	Yes
Inbuilt condensate trap/siphon	Yes	Yes
Inbuilt boiler frost protection	2 stage	2 stage
Zero compartment ventilation	Yes	Yes
Pump	Grundfos	Grundfos
<b>Clearances</b>		
Top (mm) (from top of boiler)	300	300
Side (mm)	0.5*	0.5*
Bottom (mm)	300	300
Front (mm) <sup>2</sup>	600**	600**
<b>User Interface</b>		
User display	Super Bright LCD	
Diagnostics	Advanced	Advanced
User adjustable CH temp control	Yes	Yes
User adjustable DHW temp control	Yes	Yes
<b>Pipes</b>		
Optional spacing frame	Yes	Yes
Water connections	2x22/2x15mm	2x22/2x15mm
<b>Flues</b>		
Max horizontal ø60/100	9m	9m
Max vertical ø60/100	9m	9m
Max horizontal ø80/125	25m	25m
Max vertical ø80/125	25m	25m
Optional plume management kit ø60/100	Yes	Yes

\*See manual for clearance if side panels are to be removed to assist future service and maintenance  
 \*\*5mm if removable panel or door

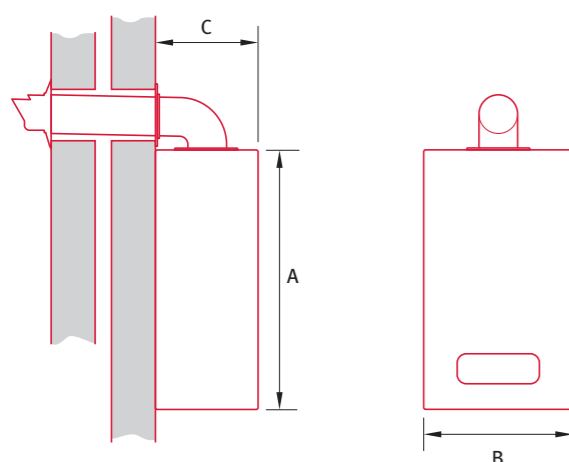

## Boiler dimensions

Height (A)	Width (B)	Depth (C)
740mm	418mm	300mm

# Intelligent controls

All Glow-worm controls have been designed to work exclusively with current Glow-worm boilers, so they are simple to install and your customer will get the ultimate in running efficiency, convenience and comfort. The Easicom<sub>2</sub> features an inbuilt analogue timer, and it is also compatible with the full range of Glow-worm controls.

## The world of controls explained

**eBus** is Glow-worm's unique communication protocol that ensures our user controls can work intelligently with a Glow-worm boiler to achieve load and weather compensation.

**Load compensation** uses the controls intelligently with the boiler to directly adjust the flow temperature to increase customer comfort levels. If the room is cold the hotter the flow temperature to the radiators. As the room gets warmer the flow temperature is cooler. Less time is needed to reach a set temperature, room temperature is more stable and the system is more efficient which lowers energy bills.

**Weather compensation** uses our outdoor sensor to measure outside temperature and adjusts the flow temperature to meet daily heating demands. The colder it is outside, the hotter the flow temperature to the radiators. As the weather gets warmer the flow temperature is cooler. This ensures the boiler operates in the most efficient way to maintain stable temperature levels and lower energy bills further.

## Simple controls packs

We've developed a choice of controls packs to suit each different user requirement

### Climapro<sub>1</sub> Programmable Thermostat Pack

- Secure wall mounted thermostat is wired using simple low voltage eBus
- User friendly design with bright backlight
- Clear straightforward menus to set heating & hot water programmes
- Annual service reminder and auto daylight saving time
- eBus connected Climapro<sub>1</sub> means the boiler will modulate to manage heating in the most efficient way possible
- Weather compensation using a simple wireless outdoor sensor



Plug in Timer	
Room Thermostat	
Programmable Room Thermostat	✓
Wireless controls	
Load Compensation	✓
Weather Compensation*	✓

\*When a outdoor sensor is included

### Climapro<sub>2</sub> RF Wireless Programmable Thermostat Pack

- Wireless thermostat works anywhere in the home
- Wall bracket for base location and secure storage
- RF receiver slots into the boiler, simple wireless setup, no electrician required
- User friendly design with bright backlight
- Clear straightforward menus to set heating & hot water programmes
- Annual service reminder and auto daylight saving time
- eBus connected Climapro<sub>2</sub> RF means the boiler will modulate to manage heating in the most efficient way possible
- Weather compensation using a simple wireless outdoor sensor



Plug in Timer	
Room Thermostat	
Programmable Room Thermostat	✓
Wireless controls	✓
Load Compensation	✓
Weather Compensation*	✓

\*When a outdoor sensor is included

### MiGo App based Programmable Thermostat Pack

- Smart phone App for iPhone & Android devices to manage heating & hot water on the go
- In room thermostat can be wall mounted or available as a portable table top version
- eBus connected MiGo means the boiler will modulate to manage heating in the most efficient way possible
- User profiles, energy usage reports, error reports
- Weather compensation using a simple wireless outdoor sensor



Plug in Timer	
Room Thermostat	
Programmable Room Thermostat	✓
Wireless controls	✓
Smartphone App controls	✓
Load Compensation	✓
Weather Compensation*	✓

\*When a outdoor sensor is included

### Multi-zone system heating controls Pack

- A weather compensated wiring centre to manage up to 3 heating zones and 1 DHW zone
- Offers complete system management for a boiler, cylinder and also heat pump
- Works with all Climapro programmable thermostats and wireless outdoor sensor
- Allows integration to under floor heating with a 24v input
- Central installer interface with easy to use menus to access data on maintenance, fault history, system parameters
- eBus connected controls means the boiler will modulate to manage heating in the most efficient way possible
- Weather compensation using a simple wireless outdoor sensor



Plug in Timer	
Room Thermostat	
Programmable Room Thermostat	✓
Wireless controls	✓
Load Compensation	✓
Weather Compensation*	✓

\*When a outdoor sensor is included

## Training

Glow-worm offer a range of on and offline training facilities covering the complete Glow-worm range. To find out more please call 01773 596156 or email [training@glow-worm.co.uk](mailto:training@glow-worm.co.uk)

## Support

Expert advice and support from installation to maintenance

### Technical help

- If you have a technical question simply call our technical help line on 0330 100 7679 or email [technical@glow-worm.co.uk](mailto:technical@glow-worm.co.uk) for a straightforward answer

### System design

- Glow-worm's award winning Design Service is a complete service tailored to suit your individual site requirements
- We use state of the art CAD technology to provide quality designs supported by full indemnity cover

### Genuine high quality spares

- Spares availability for up to 15 years after production ends
- Nationwide spares stockists with over 500 locations
- Next day delivery service for emergency orders - contact spares on 01773 596 090 or [spares@glow-worm.co.uk](mailto:spares@glow-worm.co.uk)

## Nationwide after sales service

- Supporting you with technical help and after sales service online, over the telephone and on the road
- 250 engineers based around the UK, carrying over 1,500 different spare parts
- 97% first time fix rate

For our service department please call 0330 100 7678 or email [customerservice@glow-worm.co.uk](mailto:customerservice@glow-worm.co.uk)



# clubenergy

## The award winning loyalty programme from Glow-worm

Enjoy great member benefits when you register your Easicom installations including...



**Free 3 year warranty**  
When registered through Club Energy, option to extend



**Business Development**  
Free tools to grow your business



**Plumbing Toolbox app**  
Industry leading Plumbing Toolbox app making installations easy



**Training**  
Free training



**Business Tools**  
including instant Gas Safe notifications

## Plumbing Toolbox - The industry leading installer App for Club Energy members

Designed to make your working life easier!

The Plumbing Toolbox App includes loads of useful stuff...



**Register your Installs**



**Merchant Locator**  
no more wild goose chases



**Fix that fault**  
quick and easy fault code identification



**Every manual**  
wherever you are, right there in your pocket



**Service Reminders**  
helping to keep you organised



To find out more about how you can benefit from Club Energy or join free today visit [www.clubenergy.co.uk](http://www.clubenergy.co.uk) or call 0845 275 7018



## Literature

There are a number of easy ways for you to access Glow-worm product literature:

- Via our installer App - Plumbing Toolbox
- Via telephone 01773 596 105
- Available to download online at [www.glow-worm.co.uk](http://www.glow-worm.co.uk)
- Via email [literature@glow-worm.co.uk](mailto:literature@glow-worm.co.uk)

# Glow•worm

The energy you need



Head Office  
01773 824 639  
[info@glow-worm.co.uk](mailto:info@glow-worm.co.uk)

Literature  
01773 596 105  
[literature@glow-worm.co.uk](mailto:literature@glow-worm.co.uk)

Service Department  
0330 100 7678  
[customerservice@glow-worm.co.uk](mailto:customerservice@glow-worm.co.uk)

Installer Technical Support  
0330 100 7679  
[technical@glow-worm.co.uk](mailto:technical@glow-worm.co.uk)

Training  
01773 596 156  
[training@glow-worm.co.uk](mailto:training@glow-worm.co.uk)

Spare Parts  
01773 596 090

Club Energy  
01865 893417  
[clubenergy.co.uk](http://clubenergy.co.uk)



INVESTOR IN PEOPLE

**Glow-worm**

Nottingham Road  
Belper  
Derbyshire  
DE56 1JT  
[www.glow-worm.co.uk](http://www.glow-worm.co.uk)