

Domestic heating solutions



COMBI BOILERS \ SYSTEM BOILERS \ OPEN VENT BOILERS \ WATER HEATERS \ WATER CYLINDERS \ SOLAR THERMAL COLLECTORS \ AIR SOURCE HEAT PUMPS \ TRAINING

For space and water heating





heating for life

Vokèra products provide a trouble-free focal point for any central heating system. Our extensive range offers the right choice for every home and application.

Choosing the right boiler shouldn't have to mean limited choice. Our range comes in a variety of outputs suitable for any domestic application.

Versatile flueing options and natural gas/LPG flexibility means that virtually any home can enjoy the benefits of a Vokèra boiler.

And now you can couple a Vokèra boiler with Vokèra renewable technology products, harnessing the earth's natural resources.

warmth



Vokèra Home Heating Solutions		4
<hr/>		
HE Boiler Systems for Domestic Applications		
Fuelsaver	Passive flue gas heat recovery device	8
Linea One	High efficiency combi boiler	10
Unica i	High efficiency combi boiler	14
Unica Balcony HE	High efficiency balcony combi boiler	16
Vision C	High efficiency combi boiler	18
Compact A	High efficiency combi boiler	20
Verve	High efficiency heat only boiler	22
NEW Mynute i	High efficiency sealed system boiler	24
Vision S	High efficiency sealed system boiler	26
Mynute VHE	High efficiency open vent boiler	28
<hr/>		
Water Cylinder and Water Heater		
AquaFlow	Unvented single coil water cylinder	30
AquaNova	Instantaneous multipoint water heater	31
<hr/>		
HE Boiler Range for Commercial Applications		
CondexaPRO	Wall hung condensing boiler	32
CondexaPRO Box	Floor standing condensing boiler box units	32
<hr/>		
Specialist Application Boilers		
Compact SE	Specialist application combi boiler	34
Mynute SE	Specialist application system boiler	35
<hr/>		
Domestic Boiler Feature Quick Reference Chart		36
Flue Guidance and Options		37
Choosing the Right Control	Time, energy saving and intelligent controls	41
<hr/>		
Government Financial Incentives For Energy Efficiency Improvements		43
<hr/>		
Renewables Energy Solutions - Solar Thermal Systems		
Introducing Solar thermal technology and the Vokèra Zenith range		44
Zenith Evacuated Tube	MCS accredited Solar thermal collectors	45
Zenith On Tile	MCS accredited Solar thermal collectors	46
Zenith Inset	MCS accredited Solar thermal collectors	46
AquaFlow Twin	Unvented twin coil water cylinder	47
<hr/>		
Renewables Energy Solutions - Heat Pump Systems		
Introducing air source heat pump technology and the Vokèra AriaPRO range		48
AriaPRO	MCS accredited air source heat pump	49
<hr/>		
Vokèra Support		
Technical Training		50
Customer Care and Quality Assurances		51

Vokèra Home Heating Solutions

Quality and reliability

More than 1.5 million Vokèra boilers have been installed around the UK and Ireland demonstrating our wealth of experience in home heating. Vokèra is recognised for the quality and reliability of its products with one of the highest reliability statistics in the market coupled with a 30 year unblemished record of product quality. At every stage, from research and development through to production and after sales support, we build quality in as standard. Safety is our number one priority, Vokèra is ISO 9001 approved, supports the 'benchmark' initiative, are members of the Heating and Hot Water Industry Council, Association of Plumbing and Heating Contractors, the Energy Utilities Alliance and Gas Safe Register.

In support of this we back our Vision boiler range with a 5 or 7 year warranty option, our Linea One, Unica i and Mynute i ranges with a 5 year warranty and our other boiler ranges with a 2 year warranty.

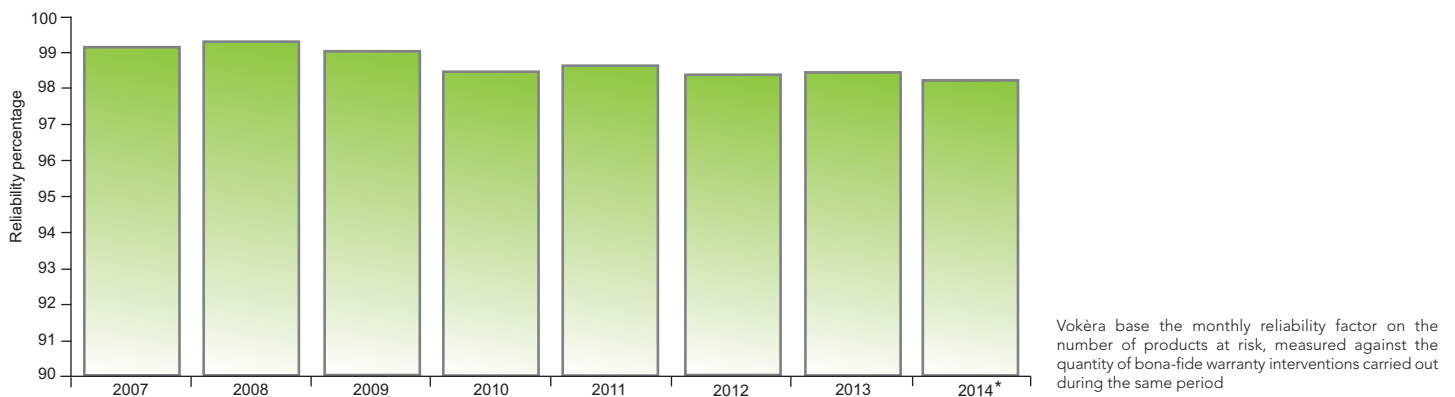

Vokèra reliability statistics 2007 - May 2014*

Choice

Vokèra specialises in the domestic and light commercial market and provides products that fulfil modern requirements. Our product range incorporates a product for every domestic application, including high efficiency combination, system and open vent boilers, light commercial boilers and water heaters and cylinders.

Our product range also incorporates boilers for specialist applications, introduced to satisfy demand for boiler replacements on SE and U ducts and for those applications deemed exempt under the Building Regulations (England and Wales) and Building Standards (Scotland).

Vokèra Renewable energy technology products are MCS approved demonstrating their quality and reliability. Renewable products available include the Zenith Solar thermal range and AriaPRO air source heat pumps.

Versatility

Vokèra boilers are available in natural gas with kits available to allow simple conversion to LPG. A wide range of flue options means that Vokèra appliances are extremely versatile – there isn't any place in the home where they can't be installed.

Service and support

Our support network incorporates a Pre Sales support advice service, Technical Training, Technical Support service and a Customer Care team dedicated to providing great service.

Vokèra employed engineers and approved agent network support every installation, giving you peace of mind that should you need us, we are there. Our engineers boast a 93% first time fix rate, ensuring a rapid resolution should any Vokèra appliance develop a fault during the warranty period. We regularly publish our customer satisfaction results on our website, these not only demonstrate our commitment to continual improvement, but the high levels of 99% satisfaction we consistently achieve every year.*

*Vokèra calculates its monthly customer satisfaction results by the total number of customer calls our engineers attend versus customer complaints.



High efficiency condensing technology

The latest technology is used to maximise the efficiency of all Vokèra products. All Vokèra high efficiency boilers conform to the SEDBUK requirements of the Building Regulations. SEDBUK is a government standard which measures seasonal efficiency of all boilers.

A Vokèra high efficiency model is amongst the most energy efficient boilers available today. These condensing boilers dramatically reduce wasted heat, saving money and helping to protect the environment. Most of these boilers can be fitted with additional energy saving controls to ensure they maximise energy efficiency.

Radial heat exchanger

Starting from the raw materials this key component is designed and built in-house ensuring the highest quality, no compromise. This provides maximum control over the manufacturing process, ensuring excellent flexibility and reliability of the thermal and corrosion resistant properties of the heat exchanger.

The innovative heat exchanger, found in our higher specification products, is a single piece component manufactured from superior quality aluminium alloy that has been specifically chosen for its excellent corrosion resistant properties and high thermal transfer rate. The radial design and large cross-sectional area eliminate the risk of scaling or superheated areas. No welding or localised heat treatment is necessary during the manufacture of the heat exchanger, thereby maintaining maximum integral strength and thermal qualities of the aluminium alloy.

The Linea One and Unica i combination boilers utilise the latest version of the radial heat exchanger. The new 'profile' has been developed to increase the time between any required maintenance of the heat exchanger; this has been enabled by increasing the 'pitch' of the coils thereby reducing the possibility of condense residues sticking to the outer wall of the exchanger.

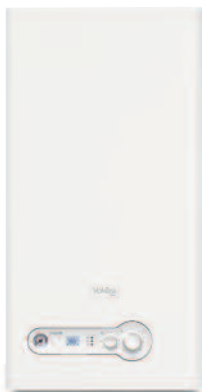

Vokèra Unica i with
10:1 modulation ratio

Class leading 10:1 modulation ratio

By incorporating the most advanced technology available, an extremely high modulation ratio of 10:1 has been achieved in the higher specification products such as the Linea One and Unica i, and up to 8:1 on the Mynute i. The modulation ratio is a boiler's ability to reduce its maximum output to its minimum output. The ability of an appliance to modulate its output to 10% of its maximum output has many benefits.

If a boiler has a maximum output of 38kW yet only has a modulation ratio of 4:1, it will only be able to modulate down to around 10kW. However, when most rooms have reached the required temperature and radiator TRVs have closed, the demand on the boiler will be considerably less than 10kW. This means that the minimum output of the boiler will be higher than it needs to be, so the boiler will constantly switch on and off, leading to fuel inefficiency. This will also place unnecessary stress on the boiler's components and parts.

A boiler with a high maximum output and a wide modulation ratio however, will be able to modulate down to an extremely low output, reducing wear and tear on primary components and increasing fuel efficiency resulting in cost savings for the end user.

Secondly, a combination boiler with a high modulation ratio is able to maintain a stable DHW (domestic hot water) flow temperature at a low flow rate, minimising any temperature fluctuations to provide a continuous flow of hot water, ensuring total end user comfort. This is particularly important for end users who prefer showers over baths or for those who require a constant DHW outlet temperature – for example, where there are young children or elderly people in a household, who are at a higher risk of scalding.

When selecting a combi boiler, it's crucial to consider modulation ratios and to remember that performance isn't just about kW output. Installing a combi boiler with a high maximum output and a wide modulation ratio will deliver optimal efficiency and comfort.



Vokèra Magnetic Filter

High efficiency boilers offer excellent performance for heating systems, however this performance can be impaired if the central heating system is not cared for. Radiators usually account for the largest surface area of a central heating system where they act as heat emitters but they are usually made up of mild steel which can corrode easily if left untreated.

Even when a corrosion inhibitor is added to the system, low levels of corrosion can still occur, forming magnetite; a black sludge like substance. Magnetite particles can be dispersed throughout the system causing blockages or restrictions that can result in a loss of performance and homeowner comfort; and can also lead to premature failure of valves and pumps which can be costly.

The Vokèra Magnetic Filter is compatible with all Vokèra domestic boilers and collects waterborne magnetite particles and any other debris that has been left within a system, offering additional protection and restoring efficiency without reducing the flow rate through the system. Easy to install on both horizontal and vertical pipe runs the Magnetic Filter's base mounted isolation valve also aids servicing and the easy discharge of the particles collected.

Vokèra Fuelsaver

The Vokèra Fuelsaver passive flue gas heat recovery system consists of a post heat exchanger device that is located between the boiler and the flue terminal and offers the potential to increase efficiency by capturing heat recovered from the flue exhaust gases that would normally be wasted. This captured heat is then used to pre-heat the incoming cold mains water supply before entering the boiler, thereby reducing gas consumption and improving domestic hot water efficiency.

The addition of a Vokèra Fuelsaver can save up to 33% of the gas normally required for DHW; save up to 500kg carbon emissions annually and reduces cold water wastage by 5% annually due to the inlet water being pre-heated.

For more information on the Fuelsaver see page 8.

Intelligent controls

Vokèra boilers boast some of the latest innovations in technology, including OpenTherm, that help maximise efficiency. We are committed to making our controls as straight forward as possible so we have incorporated this technology into the complete Vokèra combination boiler range so that they are compatible with Vokèra OpenTherm controls and devices. The OpenTherm 7 day programmable room thermostat has been configured for the Unica i range and has a 'plug and play' Tyco connection on the receiver that enables the simplest of installation to the boiler. For installation to other Vokèra ranges the Tyco connection simply needs to be re-configured or removed.

The installation of a Vokèra intelligent control provides a more comfortable and stable room temperature for the end user, in addition to helping reduce fuel bills. When installed with the Unica i, the correct use of the Vokèra OpenTherm control can save up to £67 of a home's annual energy bill*.

Most of Vokèra's current boiler range also comes with pre-configured weather compensating technology, allowing you to install the Vokèra weather compensation control with the simple addition of an external sensor.



Gas Safe Registered Installers: For a step by step video on the installation of an OpenTherm control visit the Vokèra YouTube channel (search Vokera Ltd).

For more information on the range of Vokèra controls see page 41.

*Energy saving based on average 18,000kw hrs per annum

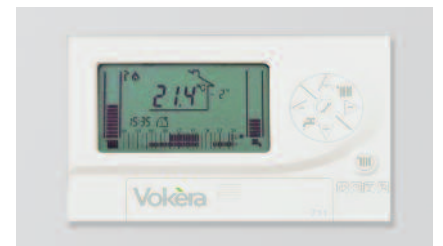

Wireless OpenTherm Control - Transmitter
Wall mounted wireless RF Transmitter (shown)



Wireless OpenTherm Control - Receiver
Tyco 'plug and play' connection on wireless OT Receiver and Unica i boiler for a simple installation.

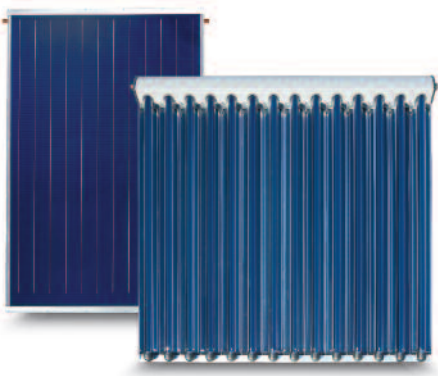

Zenith flat plate and evacuated tube Solar thermal collectors

Renewable technology

Our MCS approved high grade Zenith Solar thermal collectors maximise energy efficiency and meet the approved standard of BS EN12975 and have the Solar Keymark seal of approval.

Both the Zenith Solar thermal collectors and AriaPRO range are MCS approved, demonstrating their quality and reliability and making them eligible for government incentive schemes, such as RHPP and RHI (see page 43 for details).

The Zenith Solar thermal flat plate collectors are backed by a 10 year warranty and the evacuated tube collectors and AriaPRO air source heat pumps with a 2 year warranty.

High Power Commercial Heating Products

The CondexaPRO, a long established product range within Vokèra, makes true plant-room efficiency simple. The high reliability of products, the availability of a comprehensive line of specific accessories, the ease of mounting and the maximum flexibility, make the Vokèra CondexaPRO systems the best solution both for large domestic properties and commercial buildings, including hotels, schools, office-buildings, factories and sports centres.

CondexaPRO products are suitable both for new buildings and as a replacement of old floor-standing boilers, and thanks to their modularity, they offer the highest efficiency at any time combined with the maximum peace of mind. The availability of two different heat exchangers, giving nominal outputs of 50kW and 128kW offer a number of practical boiler variations and even more cascade configurations, up to 6.9MW, all available as natural gas or LPG.

The expert Vokèra Service team are also able to provide a commissioning service for CondexaPRO boiler installations.



CondexaPRO wall hung condensing boilers



CondexaPRO Box floor standing units. Available for internal and external installations.

Pre sales support for domestic renewable installations and commercial applications

The Vokèra Pre Sales support team offers advice on a range of products and applications to engineers, architects, specifiers and developers, ensuring you get the correct guidance and reassurance when choosing a solution for your project.

To ensure that your installation is reaching its energy efficiency potential the correct product and output must be specified. The Vokèra Pre Sales team will carry out a complete survey of your project and provide a bespoke report detailing the energy efficiency and potential energy savings of the installation, a complete bill of materials, and they can also provide on-site assistance and support with product assembly and commissioning.

Contact the Vokèra Pre Sales team: pre-sales@vokera.co.uk

Fuelsaver

Passive Flue Gas Heat Recovery Device

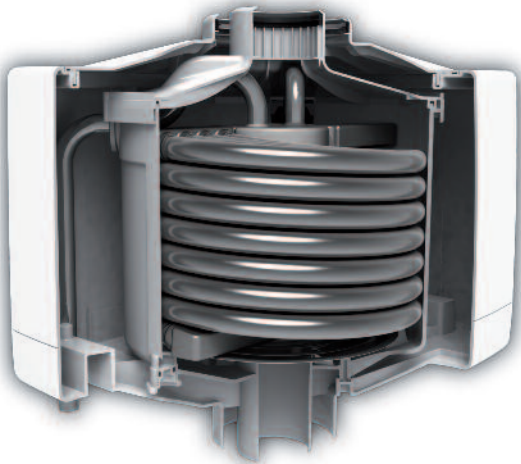

The Vokera Fuelsaver is a Passive Flue Gas Heat Recovery (PFGHR) device and can be fitted to a new or existing condensing Vokera Vision C, Unica i or Compact A combi boilers.

The post heat exchanger device is located between the boiler and the flue terminal. The device offers the potential to increase efficiency by capturing some of the heat in boiler flue gases that would normally be wasted. It uses this extracted heat to reduce the amount of fuel that has to be burned when providing hot water.

5 year parts and labour warranty.⁽¹⁾

Gas consumption is reduced saving up to 33% of the gas normally required for DHW.

Reduces carbon emissions by up to 500kg annually.

Cold water wastage is significantly reduced by 5% annually due to the inlet water being pre-heated.

Specifically developed to meet new-build requirements with low water content ensuring optimum performance.

Certified for SAP Appendix Q – helps to meet the requirements of higher levels of the Code of Sustainable Homes on new dwellings.

Enhances Energy Label Classification.

Easy to install – low lift weight and adjustable wall bracket simplify installation. Designed as a 'bolt-on' product, the Fuelsaver unit is secured to the wall and is connected directly to the appliance flue outlet. Thereafter the flue system is installed just as it would be in a normal installation.

Extremely low temperature at flue outlet, virtually eliminates any nuisance plumbing.

No separate condensate required as condensate fluid is collected and discharged via the boiler.

Can be used on both horizontal and vertical flue configurations minimising impact on the siting of the installation.

Compatible with Vokera's 60/100mm concentric flue system.

No moving parts eliminates the need for annual servicing or maintenance and permits silent operation.

Compatible with weather compensation to further improve efficiency.

Compatible with other renewable technologies.

WRAS approved product.

Does not require any electrical supply so has zero parasitical energy consumption.

Gas Safe Registered installers* require no additional trades, skill or qualifications to install the Vokera Fuelsaver.

Blending valve available as optional extra.

REDUCES GAS CONSUMPTION BY UP TO 33%

REDUCES CARBON EMISSIONS BY UP TO 500KG

(1) **5** year warranty

CERTIFIED FOR SAP APPENDIX Q

REDUCES COLD WATER WASTAGE BY 5%

NO ADDITIONAL QUALIFICATIONS NEEDED*

COMPATIBLE WITH UNICA I, VISION C AND COMPACT A BOILERS

EASY TO INSTALL WITH ADJUSTABLE BRACKET



For more information watch our short video on the Fuelsaver by visiting our YouTube channel, [search VokeraLtd.](#)

⁽¹⁾Subject to registration

Fuelsaver Installation

*Compatible with Vokèra Unica i, Vision C and Compact A combi boilers

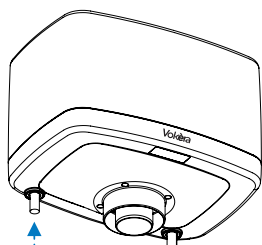

Inlet mains cold water

Outlet pre-heated water

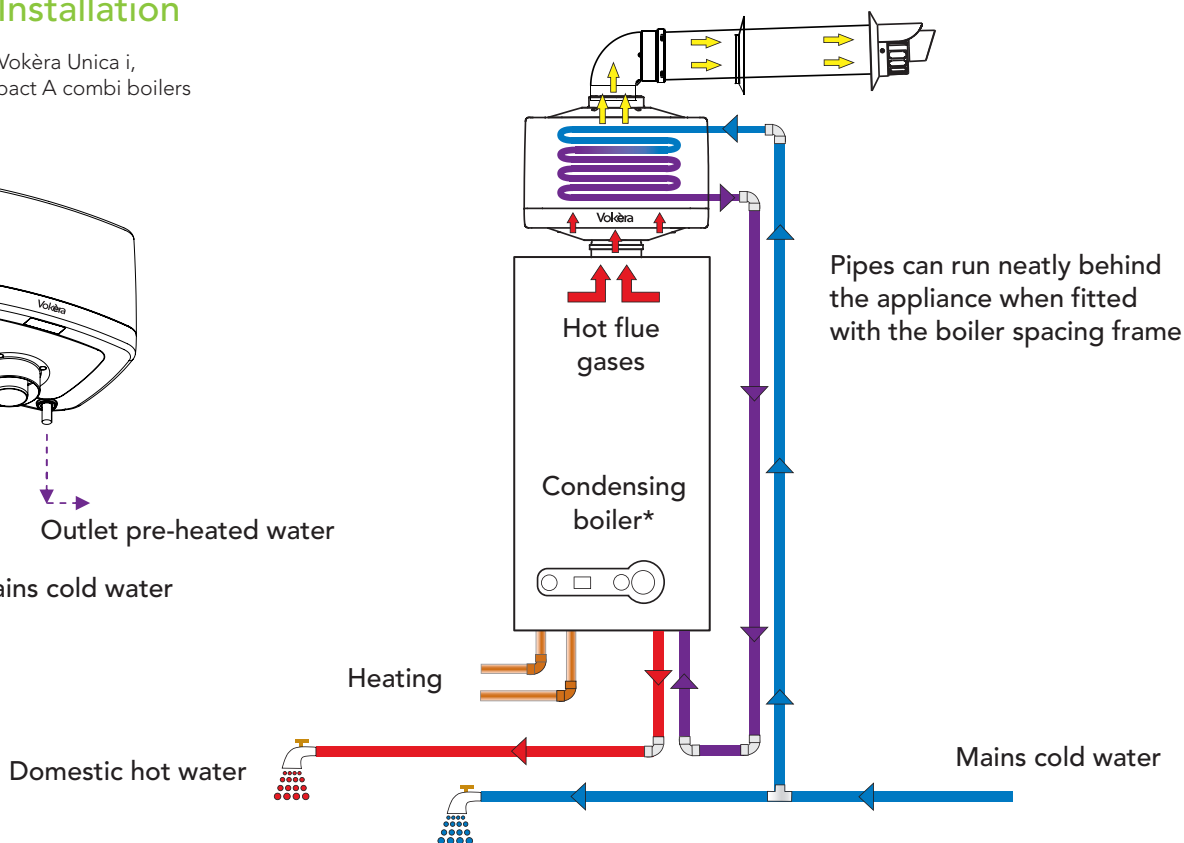

SPECIFICATIONS	Fuelsaver
Product order code	29450000
Efficiency Savings	
Gas Saving	up to 33%
Carbon Saving (annual)	Up to 500kg
Water Saving (annual)	5%
Dimensions and Weights	
Dimensions (HxWxD)	276 x 376 x 262
Lift weight empty (kg)	6.6
Lift weight full (kg)	9.4
Flue Details (concentric 60/100mm)	
Unica i28 max horizontal / vertical flue length	3.95m / 4.95m
Unica i32 max horizontal / vertical flue length	3.95m / 4.95m
Unica i36 max horizontal / vertical flue length	3.95m / 4.95m
Vision 25C max horizontal / vertical flue length	2m / 3m
Vision 30C max horizontal / vertical flue length	1m / 2m
Compact 25A max horizontal / vertical flue length	2m / 3m
Compact 29A max horizontal / vertical flue length	1m / 2m

FLUE OPTIONS AND ACCESSORIES	
Description	Code
Blending valve	1150529
Telescopic horizontal flue terminal (60/100mm)	29450121
Horizontal flue terminal (60/100mm)	29450120
Vertical flue terminal (60/100mm)	29450122

DIMENSIONS AND CLEARANCES

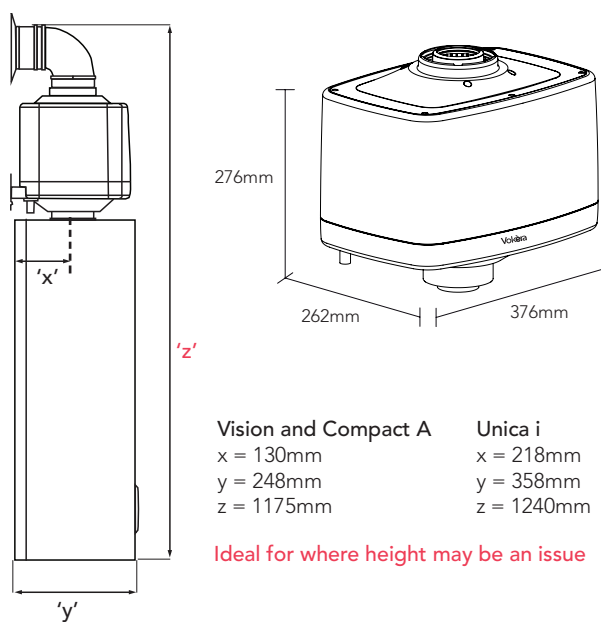

Vision and Compact A
 x = 130mm
 y = 248mm
 z = 1175mm

Unica i
 x = 218mm
 y = 358mm
 z = 1240mm

Ideal for where height may be an issue

Clearances for all boilers and Fuelsaver

Front: 600mm
 Sides: 12mm

Bottom: 15mm
 Top: 15mm*

*From casing or 25mm above flue elbow, whichever is applicable.

See page 40 for a full list of 60/100mm flue accessories

INTRODUCING LINEA ONE

The advanced heating and hot water solution from Vokèra

ALSO INCLUDED IN THE BOX:

5 YEAR WARRANTY*

—

PRE FIXING JIG FOR EASIER
INSTALLATION

—

BUILT IN FILLING LOOP FOR
INSTALLATION CONVENIENCE

—

WEATHER COMPENSATION SENSOR
TO INCREASE EFFICIENCY BY 2%**

—

PIPE COVER TO ENSURE AN
ELEGANT INSTALLATION



*Subject to registration and annual service
**As proposed in SAP 2005

*Home owners who upgrade their boiler to a condensing appliance could save up to £225 a year**

The Linea One is our top of the range appliance and has been designed to provide the complete heating and hot water solution for domestic applications. The Linea One combi boiler is one of the most energy efficient appliances on the market. By utilising the weather compensation sensor, supplied as standard with the Linea One, the SAP efficiency can be increased by a further 2%, *making the Linea One up to 92% efficient!***

Highest technology - 10:1 modulation ratio

By incorporating the most advanced technology available an extremely high modulation ratio of 10:1 has been achieved. This modulation range means that the Linea One can satisfy the heating and hot water requirements for domestic properties of different sizes, from one bedroom flats to larger detached homes whilst maintaining its efficiency. Its modulating pump can reduce electrical consumption by up to 50%, helping to reduce fuel bills and also minimise any temperature fluctuations to provide a continuous flow of hot water, ensuring total end user comfort. The Linea One is backed by a 5 year parts and labour warranty (subject to registration and annual servicing), highlighting the quality and build of the appliance.

Easy installation

A pre fixing jig and built in filling loop are supplied as standard with the Linea One, ensuring the simplest of installation. The standard Vokèra pipework layout also enables trouble-free replacements of older Vokèra models.

Complete control

The intelligent functions of the Linea One enable both the domestic hot water and central heating temperatures to be controlled. The Linea One offers the widest choice of operating functions within our boiler portfolio, ensuring home owner comfort while helping to maximise energy savings.

Intelligent 'Pre Heat Memory' function - When selected, this function adapts the appliance pre-heat function to match the users typical daily hot water usage pattern. Over a 1-week period, the boiler monitors when and how much hot water is used, thereafter the pre-heat function automatically adapts to suit the users lifestyle, ensuring that there is always an immediate supply of hot water when needed.

'Comfort' function - The 'Comfort' function allows a fixed outlet temperature for DHW within the range 35°C to 45°C (factory set at 40°C) to be set. By choosing to operate this function you ensure that the DHW is of a comfortable and safe temperature which is especially useful if there are young children or elderly relatives in the home.

The simple to use controls detail the current operating mode on a back lit display so it is clearly visible and easy to adjust. The Linea One comes with the weather compensation sensor supplied as standard and is also compatible with the OpenTherm programmable room thermostat. (For further information on these controls please see p41).

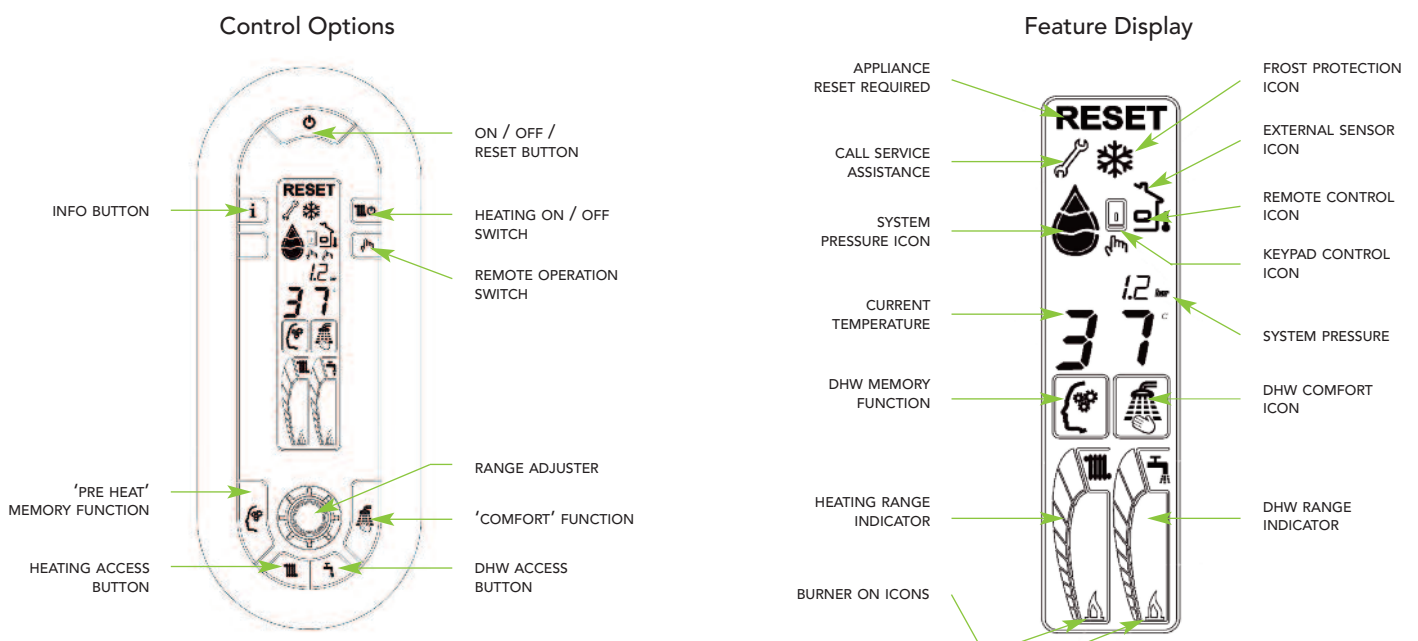

*The savings for the condensing boiler upgrade are for changing from an old G rated boiler to an A rated condensing boiler and a full set of heating controls. Source EST. **As proposed in SAP 2005

Linea One

High efficiency combi boiler

- UP TO 92% EFFICIENT ⁽¹⁾
- 5 year warranty ⁽²⁾
- IN-HOUSE PATENTED HEAT EXCHANGER
- PRE FIXING JIG AND BUILT IN FILLING LOOP
- 
- MODULATION RATIO 10:1
-  WEATHER COMPENSATION SENSOR SUPPLIED
-  PIPE COVER



Pipe cover included, supplied in the box.



SEDBUK A rated and up to 92% efficient when installed with the weather compensation sensor⁽¹⁾, supplied as standard with the Linea One.

Energy Saving Trust Recommended certification mark.

Fully modulating pump can be controlled using several modes of operation and can reduce electrical consumption by up to 50%.

5 year parts and labour warranty.⁽²⁾

Flow rate of up to 15.6 l/min results in quick delivery of hot water and meets NHBC performance requirements for combi boilers in properties with multiple bathrooms.

DHW memory function memorises the DHW usage pattern over past 7 days and uses the stored data to plan the pre heat function for the duration of the following week. The standard pre heat function is therefore only enabled when necessary, maximising energy savings.

Low NOx – Class-5 performance with only 29mg/kWh.

The easy to use appliance interface and controls permits the end user to view, change and adjust the operating mode of the boiler.

Versatile flue options with concentric flue lengths up to 12m and twin flue lengths up to 30m.

Use the Vokèra push fit telescopic flue for a quick and simple installation.

Designed for easy installation with a pre-fixing jig supplied and built-in filling loop allows the system to be connected without the boiler needing to be in place.

Extremely high modulation ratio of 10:1 maximises efficiency and comfort for end user.

Built-in frost protection, protects the appliance from damage during periods of cold weather.

Simple commissioning, only minimal adjustments are required after installation and automatic modulation eliminates the need to range rate the boiler.

Anti-seize function protects the pump and motorised valve from sticking during long periods of inactivity.

Our in-house patented heat exchanger incorporates a unique radial design utilising an extruded aluminium alloy. Aluminium has excellent thermal transfer properties and our updated design incorporates a new profile that inhibits the build-up of condensate residues, thereby significantly reducing the frequency of cleaning.

Easy to understand diagnostic display speeds installation and commissioning and aids the service engineer in the unlikely event of a fault developing.

Enhanced Autostop disabling function⁽³⁾ with 4 optional modes of operation, including: service reminder, reducing the output of the boiler, supply DHW only and moving the boiler into standby mode (no heat or DHW). Helping Registered Social Landlords fulfill their legal obligation of an annual gas safety check.

Can be converted to LPG with LPG Kit.

Incorporates Vokèra's Cyclonic Separator, providing a significant improvement in the effectiveness of the 'air separator' and can also capture particulates from the system water.

ENERGY SAVING CONTROLS AND OPTIONS

Description	Code
OpenTherm RF programmable room stat	20050690
Wiring Kit for use with OpenTherm	1221179
Telescopic flue terminal	29450121
Spacing frame	435
Condensate pump	404
Linea One LPG conversion kit	01500544
Magnetic filter	29450199

⁽¹⁾When installed with a Vokèra intelligent control, as proposed in SAP 2005

⁽²⁾Subject to registration and annual service

⁽³⁾Autostop activation device required. Contact Vokèra technical for advice

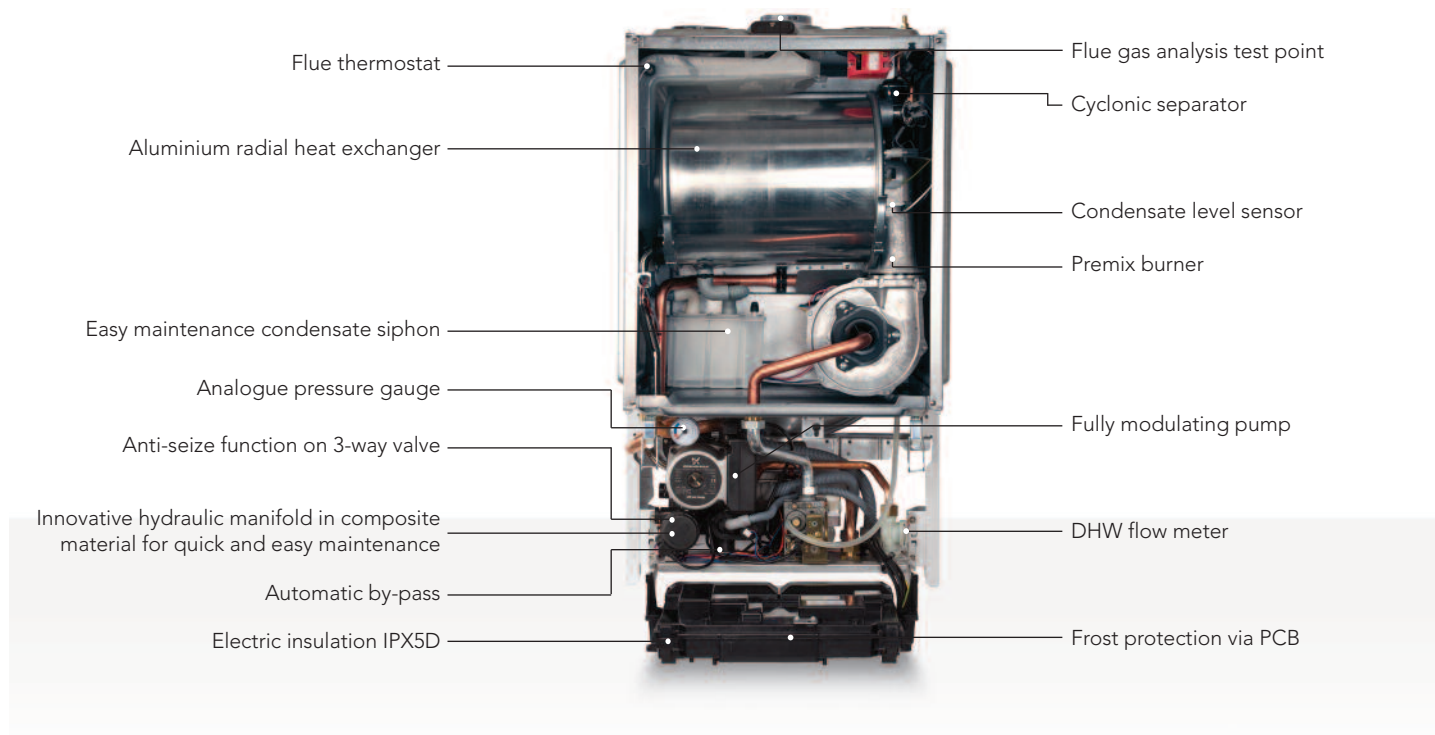

SPECIFICATIONS	Linea One 38HE
Product order code	20023491
Central Heating	
Heat input (kW)	30
Maximum heat output @ 80/60°C (kW)	29.3
Maximum heat output @ 50/30°C (kW)	32
Minimum heat output @ 80/60°C (kW)	3.8
Minimum heat output @ 50/30°C (kW)	3.8
Domestic Hot Water	
Maximum heat input (kW)	38
Minimum heat input (kW)	3.8
Flow Rate - 35°C rise (l/min)	15.6
Minimum flow rate (l/min)	2.0
Weight	
Dry weight (kg)	44
Connections	
Flow & return	22mm
Gas	15mm
DHW hot & cold	15mm
Safety valve	15mm
Condense	21mm
Electrical	
Voltage (V/Hz)	230/50
Flue Details (concentric)	
Maximum horizontal flue length (60/100mm)	3.85m
Maximum vertical flue length (60/100mm)	4.85m
Maximum horizontal flue length (80/125mm)	10m
Maximum vertical flue length (80/125mm)	12m
Flue Details (twin pipes)	
Maximum horizontal flue length (80mm/80mm)	30m/30m
Maximum vertical flue length (80mm/80mm)	30m/30m
Efficiency	
Efficiency ⁽⁴⁾ (%)	90.1
NOx class	5

⁽⁴⁾SEDBUK 2005

DIMENSIONS AND CLEARANCES (MM)

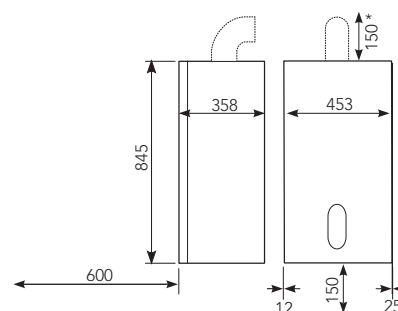

*From casing or 25mm above flue elbow (whichever is applicable)

ENVIRONMENTALLY FRIENDLY

Vokèra are committed to creating the most environmentally friendly products available and continue to invest in limiting emissions such as CO₂ and NO_x. The Linea One boasts both impressive energy efficiency ratings and has the best class for NO_x emissions.

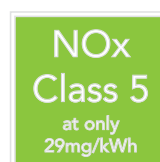

Up to 92% efficient, the Linea One is an industry leader and one of the most energy efficiency combination boilers currently available. With up to 92% of the fuel used being converted into heat, emissions are kept to a minimum.



To achieve maximum credits with a condensing boiler, under the Code for Sustainable Homes the NO_x must be below 40mg/kWh. Significant research and development have enabled the Linea One to declare a NO_x emissions of only 29mg/kWh.

Unica i

High efficiency combi boiler

- UP TO
92.4%
EFFICIENT ⁽¹⁾
-  REAR
FLUE
OPTION
-  **5**
year
warranty ⁽²⁾
-  ENERGY SAVING TRUST
recommended
- PRE FIXING JIG
AND BUILT IN
FILLING LOOP
- 10:1**
MODULATION
RATIO
- OPENTHERM
'PLUG AND
PLAY'



SEDBUK A rated and up to 92.4% efficient when installed with the weather compensation sensor or OpenTherm control⁽¹⁾, reducing running costs by up to 35% more than a conventional boiler which helps to safeguard the environment.

5 year parts and labour warranty.⁽²⁾

Versatile flue options with concentric flue lengths up to 20m and twin flue lengths up to 45m.

Energy Saving Trust Recommended certification mark.

Low NOx - Class-5 performance provides maximum credits available for a condensing boiler under the Code for Sustainable Homes.

Front mounted heat exchanger assists in simple maintenance.

Our in house patented heat exchanger incorporates a unique radial design utilising an extruded aluminium alloy. Aluminium has excellent thermal transfer properties and our updated design incorporates a new profile that inhibits the build-up of condense residues, thereby significantly reducing the frequency of cleaning.

Designed for easy installation with a pre-fixing jig supplied and built-in filling loop allows the system to be connected without the boiler needing to be in place.

Extremely high modulation ratio of 10:1 maximises efficiency and comfort for end user. Other energy saving features, including low power consumption, make the Unica i extremely efficient.

Built-in frost protection, protects the appliance from damage during periods of cold weather.

Simple to use back-lit LCD display ensures end-users can easily operate and adjust the appliance.

Compatible with energy saving controls including outside weather compensation sensor or the new OpenTherm control with a 'Plug and Play' connection for a simple installation. The OpenTherm control can save a further £67 a year off energy bills.⁽³⁾



Rear flue option as well as the standard top flue option provides a versatile installation. Other flueing options available are; horizontal, vertical and twin flue, enabling the boiler to be sited almost anywhere in the home.

Easy to understand diagnostic display aids the service engineer in the unlikely event of a fault developing.

Standard Autostop disabling function⁽⁴⁾ that automatically changes the current operating mode and moves it permanently into the standby mode, helping Registered Social Landlords fulfill their legal obligation of an annual gas safety check. Autostop will only operate after a pre-defined period of time has elapsed and if it has been activated during commissioning.

Incorporates Vokera's Cyclonic Separator, providing a significant improvement in the effectiveness of the 'air separator' and can also capture particulates from the system water.

Can be converted to LPG with LPG Kit.

Compatible with Vokera Fuelsaver passive flue gas heat recovery device. Heat recovered from the flue exhaust gases is used to pre-heat the incoming cold mains water supply before entering the boiler, thereby reducing gas consumption and improving domestic hot water efficiency. See page 8 for more information.



ENERGY SAVING CONTROLS AND OPTIONS

Description	Code
Rear flue terminal	29450133
Telescopic flue terminal	29450121
OpenTherm RF programmable room stat with 'Plug and Play' connection to the Unica i	20050690
Weather compensation sensor	2359259
White pipe cover 400mm	518
Spacing frame	435
Magnetic filter	29450199
Fuelsaver	29450000

⁽¹⁾When installed with a Vokera intelligent control, as proposed in SAP 2005

⁽²⁾ Subject to registration and annual service. ⁽³⁾ Energy saving based on average 18,000kw hrs per annum. ⁽⁴⁾ Autostop activation device required. Contact Vokera Technical Helpline for advice.

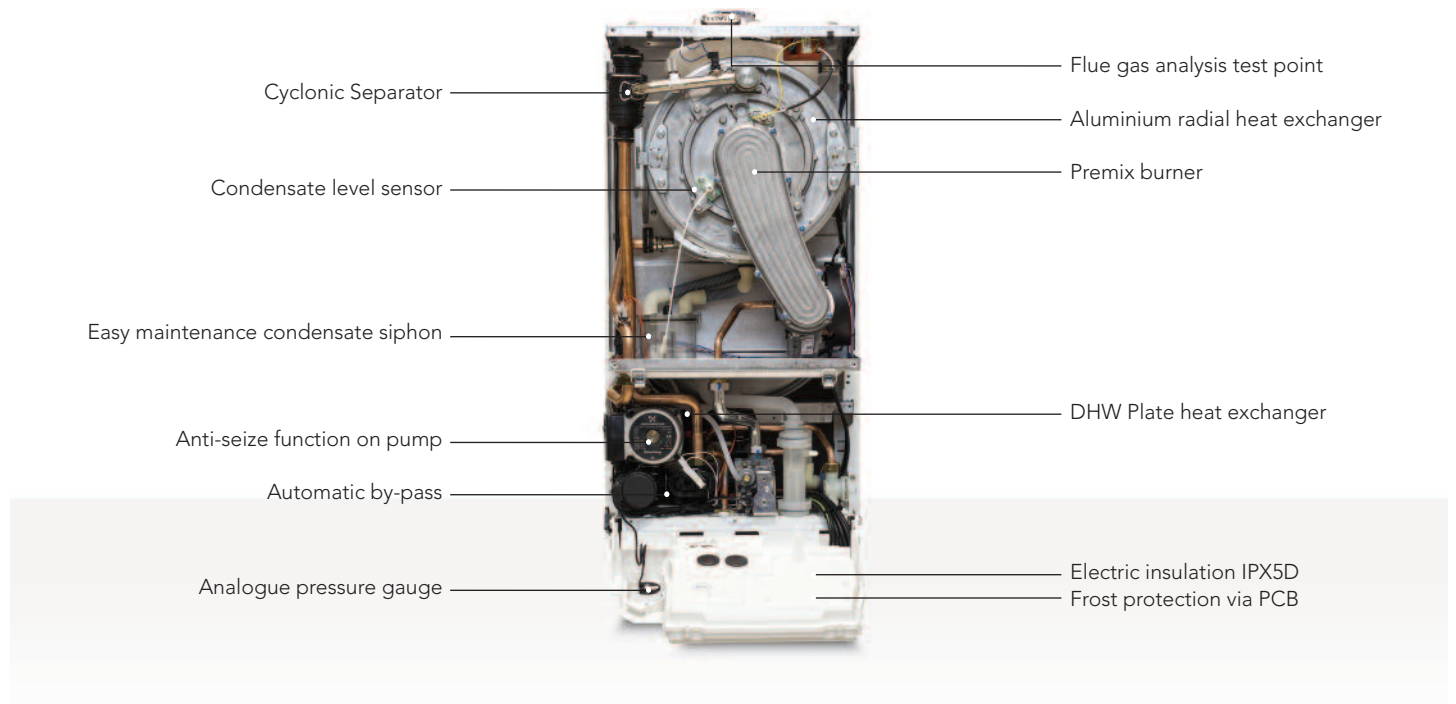

SPECIFICATIONS	Unica i28	Unica i32	Unica i36
Product order code	20037856	20037857	20065834
Central Heating			
Heat input (kW)	20	25	30
Maximum heat output @ 80/60°C (kW)	19.6	24.6	29.3
Maximum heat output @ 50/30°C (kW)	21.4	26.7	31.8
Domestic Hot Water			
Heat input (kW)	28	32	36
Flow Rate - 35°C rise (l/min)	11.5	13.1	14.7
Weight			
Dry weight (kg)	39	40	41
Connections			
Flow & return	22mm	22mm	22mm
Gas	15mm	15mm	15mm
DHW hot & cold	15mm	15mm	15mm
Safety valve	15mm	15mm	15mm
Condense	21mm	21mm	21mm
Electrical			
Voltage (V/Hz)	230/50	230/50	230/50
Flue Details (concentric)			
Maximum horizontal flue ⁽⁶⁾ length inc. rear flue (60/100mm)	7.8m	7.8m	7.8m
Maximum vertical flue ⁽⁶⁾ length (60/100mm)	8.8m	8.8m	8.8m
Maximum horizontal flue length (80/125mm)	18m	18m	18m
Maximum vertical flue length (80/125mm)	20m	20m	20m
Flue Details (twin pipes)			
Max horizontal (80mm/80mm)	45m/45m	45m/45m	45m/45m
Max vertical (80mm/80mm)	45m/45m	45m/45m	45m/45m
Efficiency			
Efficiency ⁽⁵⁾ (%)	90.3	90.4	90.1
NOx class	5	5	5

⁽⁵⁾ SEDBUK 2005 ⁽⁶⁾ Deduct 3.85m from the maximum flue length when installed with Fuelsaver.

DIMENSIONS AND CLEARANCES (MM)

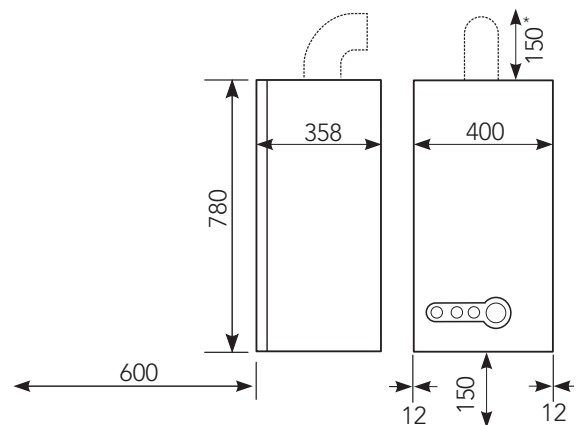

*From casing or 25mm above flue elbow (whichever is applicable)

ADDITIONAL ENERGY SAVING OPTIONS

The Unica i combi range is compatible with the new Vokèra Fuelsaver passive flue gas heat recovery device.

The Fuelsaver consists of a post heat exchanger device that is located between the boiler and the flue terminal and offers the potential to increase efficiency by capturing heat recovered from the flue exhaust gases that would normally be wasted. This captured heat is then used to pre-heat the incoming cold mains water supply before entering the boiler, thereby reducing gas consumption and improving domestic hot water efficiency.

The addition of a Vokèra Fuelsaver can:





- Save up to **33%** of the gas normally required for DHW
- Saves up to **500kg** carbon emissions annually
- Reduces cold water wastage by **5%** annually due to the inlet water being pre-heated

Certified under SAP Appendix Q

Unica Balcony HE

High efficiency balcony combi boiler

- 92.2% EFFICIENT**
(1)
- 
2 year warranty
- DESIGNED FOR EXTERNAL INSTALLATIONS**
- IN-HOUSE PATENTED HEAT EXCHANGER**
- 
PIPE COVER



Pipe cover included, supplied in the box.



SEDBUK A rated and up to 92.2% efficient when installed with the weather compensation sensor⁽¹⁾, reducing running costs by up to 35% more than a conventional boiler which helps to safeguard the environment.

Designed specifically for external installations, requiring only limited protection to withstand typical UK weather conditions.⁽²⁾

Optional galvanised box to reduce possible vandalism and to help protect against adverse weather conditions and low temperatures.

Low NOx - Class-5 performance.

Full IPX5D rating enables the Unica BHE to be installed either on a balcony or on an external wall.

Ideal for problematic installations such as; flats with limited space, if there are difficulties with flue clearances or if a long run to an adequate soak away for the condensate are foreseen.

Simple commissioning, only minimal adjustments are required after installation and automatic modulation eliminates the need to range rate the boiler.

Extremely high modulation ratio, increasing efficiency and component longevity.

Hot water pre-heat provides instant hot water, saving time and energy.

Anti seize function protects the pump and motorised valve from sticking during long periods of inactivity.

Anti-cycling control prevents energy wasteful on/off cycling and reduces wear and tear.

Built-in frost protection, protects the appliance from damage during periods of cold weather.

Additional external frost protection kit available for when temperatures are expected to reach temperatures as low as -10°C.

Intuitive control panel ensures end-users can easily operate and adjust the appliance.

Standard Autostop disabling function⁽³⁾ that automatically changes the current operating mode, and moves it permanently into the standby mode, helping Registered Social Landlords fulfill their legal obligation of an annual gas safety check. Autostop will only operate after a pre-defined period of time has elapsed and if it has been activated during commissioning.

Versatile flueing options that can reach lengths up to 40 metres.

Built-in thermo-regulation to increase further fuel efficiency. Attach an energy saving control to increase energy efficiency.

Can be converted to LPG with LPG Kit.

ENERGY SAVING CONTROLS AND OPTIONS

Description	Code
REC07 programmable room thermostat	1221169
Weather compensation sensor	2359259
Galvanised box	1103289
Telescopic flue terminal	29450121
Condensate pump	404
External frost protection kit	1101279
Magnetic filter	29450199
Unica BHE LPG conversion kit	01005447

⁽¹⁾When installed with a Vokera intelligent control, as proposed in SAP 2005

⁽²⁾ Some additional protection may be required for extreme weather conditions

⁽³⁾Autostop activation device required. Contact Vokera Technical Helpline for advice

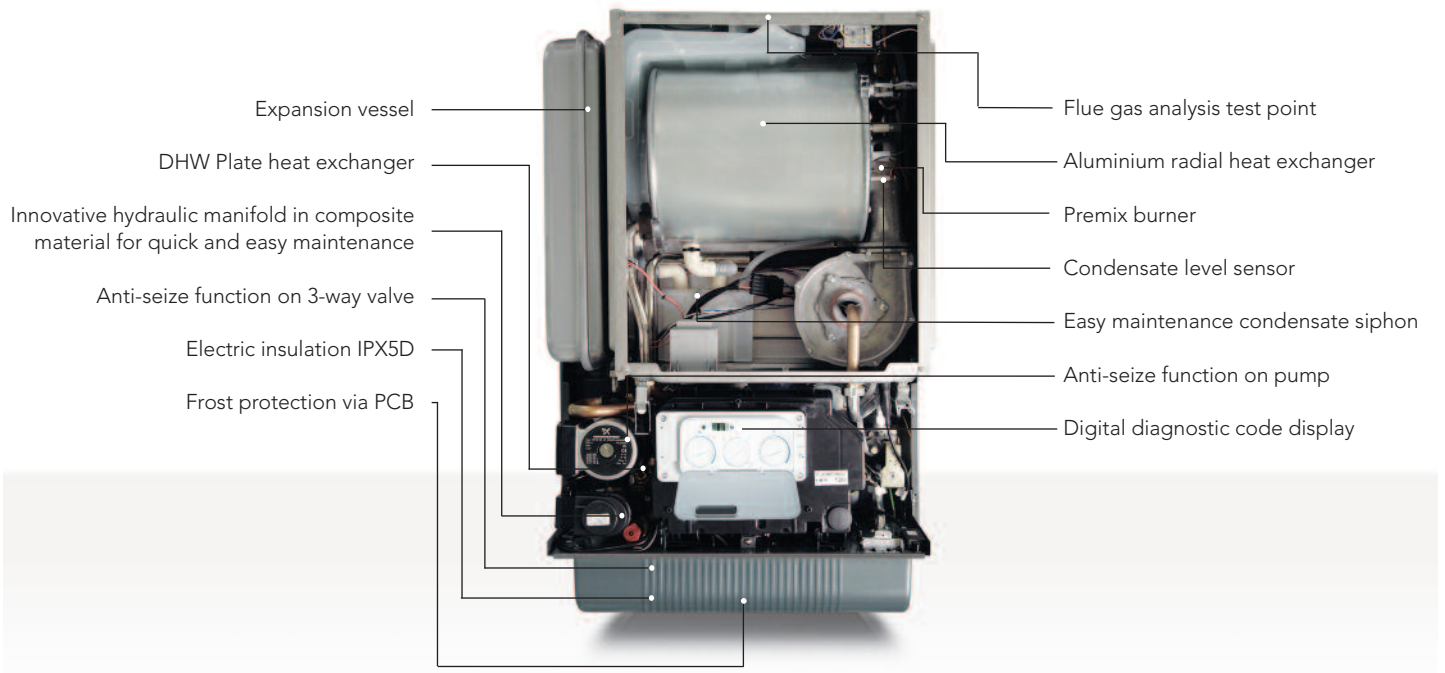

SPECIFICATIONS	Unica 32 BHE
Product order code	20001056
Central Heating	
Heat input (kW)	25
Maximum heat output @ 80/60°C (kW)	24.45
Maximum heat output @ 50/30°C (kW)	26.3
Domestic Hot Water	
Maximum heat input (kW)	32
Flow Rate - 35°C rise (l/min)	13.1
Weight	
Dry weight (kg)	44
Connections	
Flow & return	22mm
Gas	15mm
DHW hot & cold	15mm
Safety valve	15mm
Condense	21mm
Electrical	
Voltage (V/Hz)	230/50
Flue Details (concentric)	
Maximum horizontal flue length (60/100mm)	7.8m
Maximum vertical flue length (60/100mm)	8.8m
Maximum horizontal flue length (80/125mm)	20m
Maximum vertical flue length (80/125mm)	25m
Flue Details (twin pipes)	
Maximum horizontal flue length (80mm/80mm)	40m/40m
Maximum vertical flue length (80mm/80mm)	40m/40m
Efficiency	
Efficiency ⁽⁴⁾ (%)	90.2
NOx class	5

⁽⁴⁾ SEDBUK 2005

DIMENSIONS AND CLEARANCES (MM) - UNICA 32 BHE

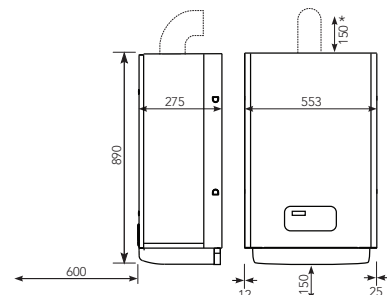

*From casing or 25mm above flue elbow (whichever is applicable)

OPTIONAL GALVANISED BOX

The Vokèra Unica BHE is designed for external installations and can withstand typical UK and ROI weather conditions. The optional galvanised box offers further protection during adverse weather and also helps prevent vandalism.

It is to be used when the boiler is installed on an external wall where there is no cover/protection from the elements. When installed below a balcony no galvanised box is required.

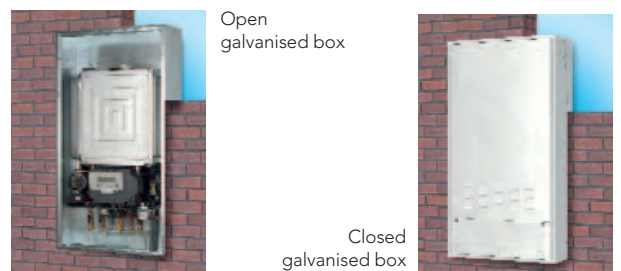

Vision C

High efficiency combi boiler

- UP TO
92.1%
EFFICIENT ⁽¹⁾
- 5 or 7** year warranty ⁽²⁾
- REAR
FLUE
OPTION
- BUILT IN
FILLING LOOP
- BUILT IN 7 DAY
DIGITAL CLOCK
- KITCHEN
CUPBOARD FIT
- LIGHTWEIGHT
FROM JUST
26KG



SEDBUK A rated and up to 92.1% efficient when installed with the weather compensation sensor or OpenTherm control⁽¹⁾, reducing running costs by up to 35% more than a conventional boiler which helps to safeguard the environment.

Built-in filling loop as standard allows the system to be connected without the boiler needing to be in place.

NEW 5 or 7 year parts and labour warranty option.⁽²⁾

Simple to use built in 7 day digital clock with 3 modes of operation and back-lit LCD display enables full control of heating timings over a 7 day period, maximising control and saving energy.

Small dimensions enables the boiler to be sited almost anywhere in the home, including a kitchen cupboard.



Rear flue option as well as the standard top flue option provides a versatile installation. Other flueing options available are; horizontal, vertical and twin flue.

Lightweight at only 26kg for the 25C enables the boiler to be lifted into place easily, even in tight spaces.

Designed for easy installation. Standard Vokera pipework layout enables trouble-free replacement of older Vokera models.

Low NOx - Class-5 performance. Only 21mg/kWhr for 25C provides maximum credits available for a condensing boiler under the Code for Sustainable Homes.

Flow rate of up to 12 l/min results in quick delivery of hot water.

DHW Pre-Heat function that is easily activated by the end user.

Standard Autostop disabling function⁽³⁾ automatically changes the current operating mode and moves it permanently into the standby mode, helping registered social landlords fulfill their legal obligations of an annual gas safety check.

Simple commissioning, only minimal adjustments are required after installation and automatic modulation eliminates the need to range rate the boiler.

Built in functions include: SARA function for automatic temperature control and improved efficiency, frost protection to protect the appliance during periods of cold weather. and CO mode for simple servicing.

Anti-cycling control prevents energy wasteful on/off cycling reduces wear and tear for longer lasting component performance.

If the boiler is to be installed in a location that is difficult to access then Vokera's optional RF room thermostat control can be installed in a convenient location so the heating temperature can easily be adjusted.

Hot water survivor function:- If the hot water thermistor fails it will use the primary thermistor to provide hot water at 55°C to ensure the end user has access to a supply of warm water.

Low temperature option for under floor heating.

Can be converted to LPG with LPG kit.

Vision system boiler also available. See page 26 for more information.

Compatible with Vokera Fuelsaver passive flue gas heat recovery device. See page 8 for more information.

⁽¹⁾When installed with a Vokera intelligent control, as proposed in SAP 2005. The addition of an energy saving control will override the built in digital control settings ⁽²⁾Subject to registration and annual service, 7 year warranty available until 31st December 2014.

⁽³⁾ Autostop activation device required. Contact Vokera Technical Helpline for advice.

KITCHEN CUPBOARD FIT



ENERGY SAVING CONTROLS AND OPTIONS

Description	Code
Rear flue terminal	29450133
Pipe cover	20012594
RF Room thermostat control	20059642
OpenTherm RF programmable room stat*	20050690
Weather compensation sensor*	2359259
Spacing frame	20030704
Condense pump	404
Magnetic filter	29450199
Fuelsaver	29450000

*Control Interface required for use with OpenTherm and weather compensation controls. Code 29450143

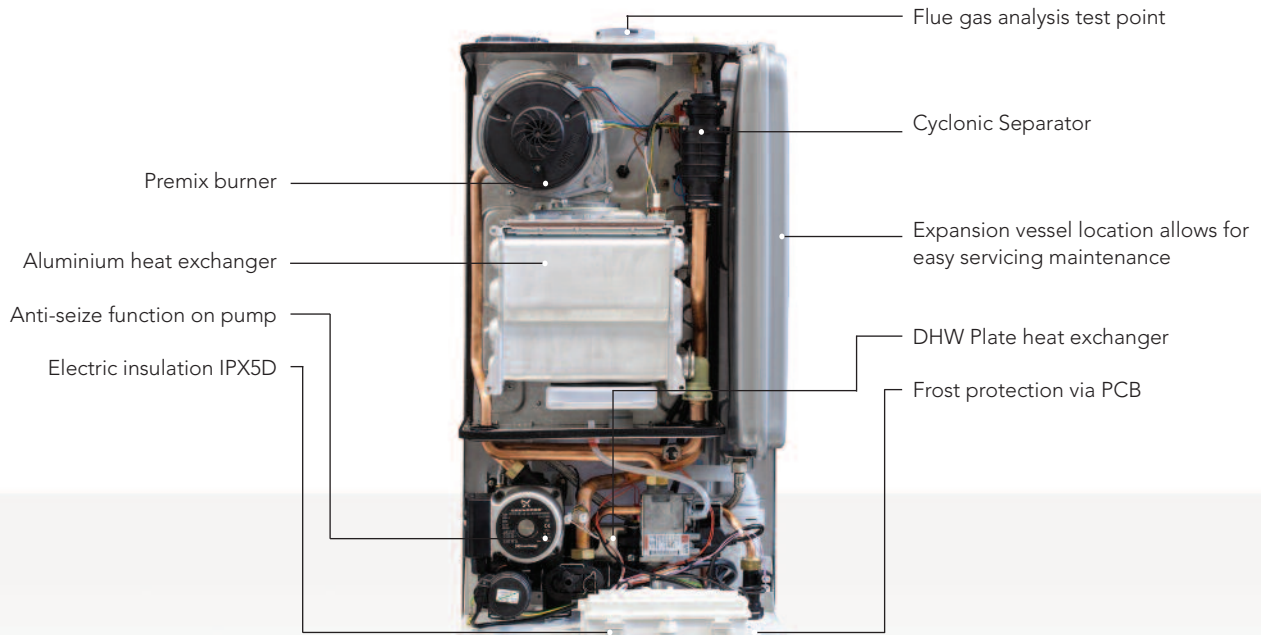

SPECIFICATIONS	Vision 25C	Vision 30C
Product order code - 5 year warranty	20052391	20052392
Product order code - 7 year warranty	29450431	29450432
Central Heating		
Max heat input (kW)	20	25
Maximum heat output @ 80/60°C (kW)	19.5	24.45
Maximum heat output @ 50/30°C (kW)	20.84	26.23
Domestic Hot Water		
Maximum heat input (kW)	25	29
Flow Rate - 35°C rise (l/min)	10.2	12
Weight		
Dry weight (kg)	26	27
Connections		
Flow & return	22mm	22mm
Gas	15mm	15mm
DHW hot & cold	15mm	15mm
Safety Valve	15mm	15mm
Condensate	21mm	21mm
Electrical		
Voltage (V/Hz)	230/50	230/50
Flue details (concentric)		
Maximum horizontal flue length ⁽⁵⁾ inc. rear flue (60/100mm)	5.85m	4.85m
Maximum vertical flue length ⁽⁵⁾ (60/100mm)	6.85m	5.85m
Maximum horizontal flue length (80/125mm)	15.3m	12.8m
Maximum vertical flue length (80/125mm)	16.3m	13.8m
Flue Details (twin pipes)		
Maximum horizontal flue length (80mm/80mm)	45m/45m	40m/40m
Maximum vertical flue length (80mm/80mm)	45m/45m	40m/40m
Efficiency		
Efficiency ⁽⁴⁾ (%)	90.0	90.1
NOx class	5	5

DIMENSIONS AND CLEARANCES (MM)

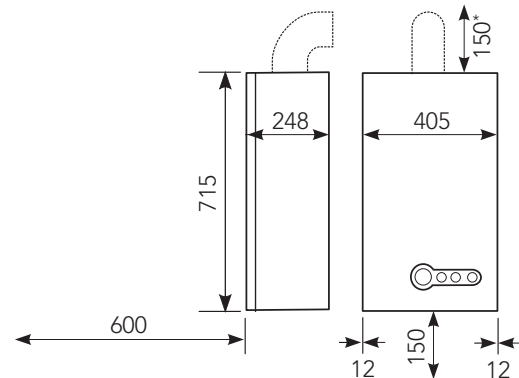

*From casing or 25mm above flue elbow (whichever is applicable)

ADDITIONAL ENERGY SAVING OPTIONS

The Vision combi range is compatible with the Vokèra Fuelsaver passive flue gas heat recovery device.

The Fuelsaver consists of a post heat exchanger device that is located between the boiler and the flue terminal and offers the potential to increase efficiency by capturing heat recovered from the flue exhaust gases that would normally be wasted. This captured heat is then used to pre-heat the incoming cold mains water supply before entering the boiler, thereby reducing gas consumption and improving domestic hot water efficiency.

The addition of a Vokèra Fuelsaver can:





Certified under SAP Appendix Q

- Save up to **33%** of the gas normally required for DHW
- Saves up to **500kg** carbon emissions annually
- Reduces cold water wastage by over **5%** annually due to the inlet water being pre-heated

⁽⁴⁾ SEDBUK 2005 ⁽⁵⁾ Deduct 3.85m from the maximum flue length when installing with the Vokèra Fuelsaver passive flue gas heat recovery device.

Compact A

High efficiency combi boiler

- UP TO
92.1%
EFFICIENT ⁽¹⁾
- 2
year
warranty
- REAR
FLUE
OPTION
- KITCHEN
CUPBOARD FIT
- PIPE COVER
AVAILABLE AS
OPTIONAL
EXTRA
- Energy Saving Trust
recommended



SEDBUK A rated and up to 92.1% efficient when installed with the weather compensation sensor or OpenTherm control⁽¹⁾, reducing running costs by up to 35% more than a conventional boiler which helps to safeguard the environment.



Rear flue option as well as the standard top flue option provides a versatile installation. Other flueing options available are; horizontal, vertical and twin flue, enabling the boiler to be sited almost anywhere in the home.

Easy to understand diagnostic display aids the service engineer in the unlikely event of a fault developing.

Energy Saving Trust Recommended certification mark.

Compact dimensions and low lift weight enables a flexible installation with the boiler to be lifted into place easily, even in tight spaces.

Attach the RF 7 day programmable room thermostat to increase efficiency and maintain optimum room temperature. Easy to install with a Tyco 'plug and play' connection, simply plug the receiver in to the boiler.

Designed for easy installation. Standard Vokèra pipework layout enables trouble-free replacement of older Vokèra models.

Hot water survivor function:- If the hot water thermistor fails it will use the primary thermistor to provide hot water at 55°C to ensure the end user has access to a supply of warm water.

Simple commissioning, only minimal adjustments are required after installation and automatic modulation eliminates the need to range rate the boiler.

Anti-cycling control prevents energy wasteful on/off cycling and reduces wear and tear.

Low NOx - Class-5 performance.

Plated heat exchanger reduces the risk of scaling and comes with 5-year anti-scale warranty.

Installation time saving features:- Built-in condensate trap with safety device and push-fit connection and no ventilation is required.

Can be converted to LPG with LPG Kit.

Selectable pre-heat function enables end-users to manually select the pre-heat function according to their own individual tastes and requirements, improving end-user comfort

Compatible with Vokèra Fuelsaver passive flue gas heat recovery device. See page 8 for more information.

CYCLONIC AIR AND PARTICLE SEPARATOR

The Compact A incorporates Vokèra's Cyclonic Separator. The Cyclonic Separator provides a significant improvement in the effectiveness of the 'air separator' and can also capture particulates from the system water. Its distinct advantages include:

- Reduced pressure loss through the hydraulic circuit of the boiler
- Quicker discharge of air during commissioning
- Possibility to now remove and clean the inside of the separator, removing any particulates that may have been trapped
- Quick-release clips – no tools required, reduces time spent on routine maintenance

N.B: This device/component is not intended to substitute or replace any requirement for an external particle separator



ENERGY SAVING CONTROLS AND OPTIONS

Description	Code
Rear flue terminal	29450133
Pipe cover	20012594
7 day RF programmable room thermostat	20059643
OpenTherm RF programmable room thermostat*	20050690
Weather compensation sensor*	2359259
Compact A 24 hour analogue clock kit	20025085
Telescopic flue terminal	29450121
Spacing frame	20030704
Compact 25A LPG conversion kit	20045569
Compact 29A LPG conversion kit	20029055
Condense pump	404
Magnetic filter	29450199

*Control Interface required. Code 29450143.

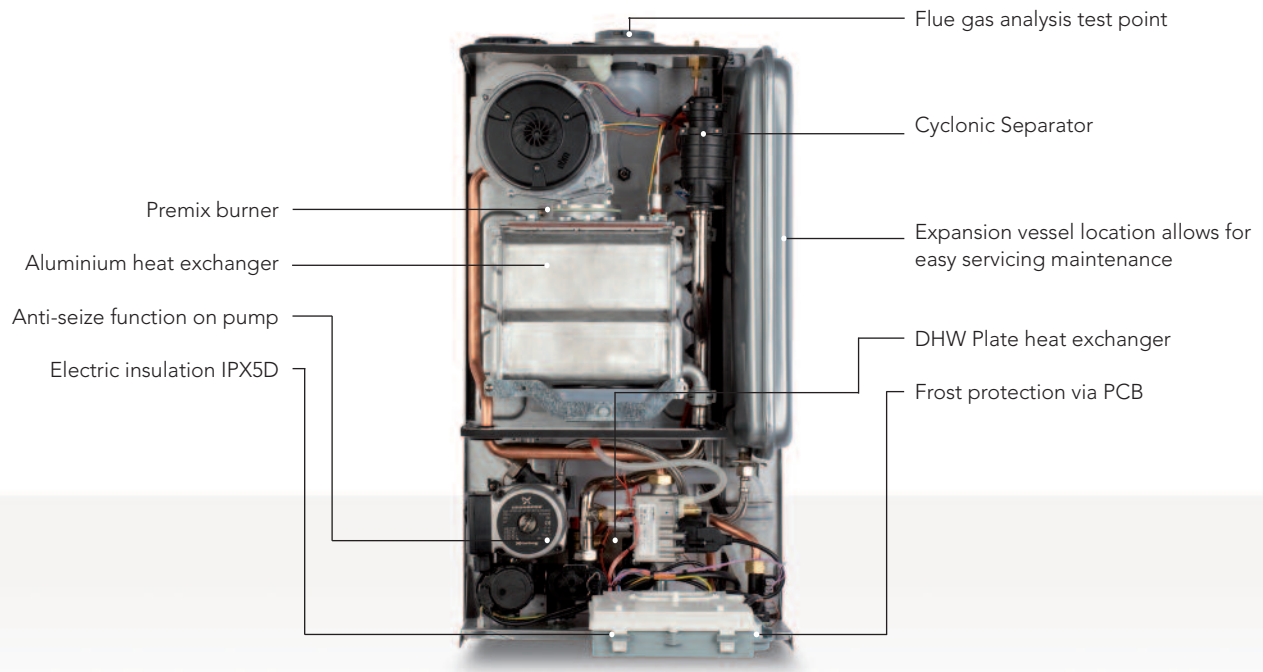

SPECIFICATIONS	Compact 25A	Compact 29A
Product order code	20071498	20071500
Central Heating		
Heat input (kW)	20	25
Maximum heat output @ 80/60°C (kW)	19.5	24.4
Domestic Hot Water		
Maximum input (kW)	25	29.5
Flow Rate - 35°C rise (l/min)	10.2	12.1
Weight		
Dry weight (kg)	26	27
Connections		
Flow & return	22mm	22mm
Gas	15mm	15mm
DHW hot & cold	15mm	15mm
Safety Valve	15mm	15mm
Condensate	21mm	21mm
Electrical		
Voltage (V/Hz)	230/50	230/50
Flue details (concentric)		
Maximum horizontal flue length ⁽³⁾ inc. rear flue (60/100mm)	5.85m	4.85m
Maximum vertical flue length ⁽³⁾ (60/100mm)	6.85m	5.85m
Maximum horizontal flue length (80/125mm)	15.3m	12.8m
Maximum vertical flue length (80/125mm)	16.3m	13.8m
Flue Details (twin pipes)		
Maximum horizontal flue length (80mm/80mm)	45m/45m	40m/40m
Maximum vertical flue length (80mm/80mm)	45m/45m	40m/40m
Efficiency		
Efficiency ⁽²⁾	90.0	90.1
NOx class	5	5

⁽¹⁾When installed with a Vokèra intelligent control, as proposed in SAP 2005 ⁽²⁾SEDBUK 2005
⁽³⁾Deduct 3.85m from the maximum flue length when installing with the Vokèra Fuelsaver.

DIMENSIONS AND CLEARANCES (MM)

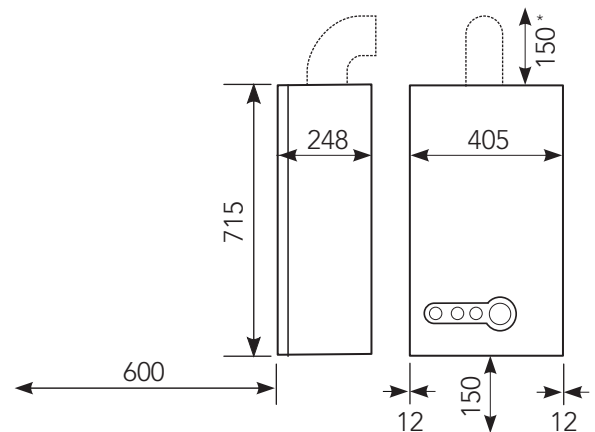

*From casing or 25mm above flue elbow (whichever is applicable)

'PLUG AND PLAY' CONNECTION FOR RF CONTROL



The 7 day RF programmable room thermostat allows easy control over boiler heating timings and temperatures over a 7 day period.

This wall mounted, battery operated, digital thermostat control enables versatile siting and ensures end user accessibility.

The receiver is easily connected to the boiler using the 'plug and play' Tyco socket ensuring the simplest of installation.

See page 42 for more information.



Verve

High output heat only boiler

92.1% EFFICIENT
(1)

2
year warranty

ALUMINIUM HEAT EXCHANGER

EXCELLENT POWER TO WEIGHT RATIO

CASCADES UP TO 200kW

COMPATIBLE WITH SOLAR THERMAL



Pipe cover supplied as standard. Not shown.

SEDBUK A rated and up to 92.1% efficient when installed with the weather compensation sensor or OpenTherm control⁽¹⁾, reducing running costs by up to 35% more than a conventional boiler which helps to safeguard the environment.

Can be cascaded up to 200kW in wall hung, free standing linear or back to back installations. See the Vokèra Commercial Catalogue for more information and example configurations.

Vokèra strongly recommend the addition of the optional hydraulic separator to ensure that the boiler operates at the required flow-rate, preventing nuisance shut down and reducing component wear and tear.

Isolating valve kit supplied as standard for simple servicing. The flow and return valve kit that enables the boiler to be isolated from the circuit – whether sealed or open-vent – eliminates any need to drain the whole system during servicing.

Optional 3 port valve enables separate zoning of space heating and hot water circuits.

Our in house patented heat exchanger incorporates a unique radial design utilising an extruded aluminium alloy. Aluminium has excellent thermal transfer properties and our updated design incorporates a new profile that inhibits the build-up of condense residues, thereby significantly reducing the frequency of cleaning.

Boiler comes with 80mm twin flue outlet allowing the flue run to go up to 20m but can easily be converted to a 60/100mm concentric flue or 80/125mm concentric flue, making installation extremely flexible.

Incorporates Vokèra's Cyclonic Separator, providing a significant improvement in the effectiveness of the 'air separator' and can also capture particulates from the system water.

The Verve is relatively lightweight at 39kg and measures in at 858mm high, 553mm wide and 284mm deep making it an ideal choice if space is an issue.

Simple installation with the Verve operating on a standard domestic gas supply, reducing installation preparation.

Low NOx - Class-5 performance.

Combustion analysis test point for easy servicing and maintenance.

Built-in SARA function for improved efficiency, anti-cycling for longer lasting component performance, frost protection and CO mode for simple servicing.

3.5 bar safety pressure relief valve.

Can be converted to LPG with LPG Kit.

Built-in thermo-regulation, attach an energy saving control⁽²⁾ to increase energy efficiency. Compatible with weather compensation sensor and OpenTherm RF control.

No internal expansion vessel but a 24 litre expansion vessel is available as an optional extra and is adequate for most systems.

Compatible with Vokèra's MCS accredited Zenith Solar thermal collectors.

⁽¹⁾When installed with a Vokèra intelligent control, as proposed in SAP 2005

⁽²⁾Contact Vokèra Technical Helpline for advice



OPTIONS

Description	Code
Hydraulic separator	20028475
3 way valve kit for DHW	20028476
B23 air intake kit	20028478
Flue kit adaptor 80/80 - 60/100	20028027
Flue kit adaptor 80/80 - 80/125	20028029
24l expansion vessel	20043324
OpenTherm RF control ⁽²⁾	20050690
Weather compensation sensor ⁽²⁾	2359259
Condense pump	404
Magnetic filter	29450199

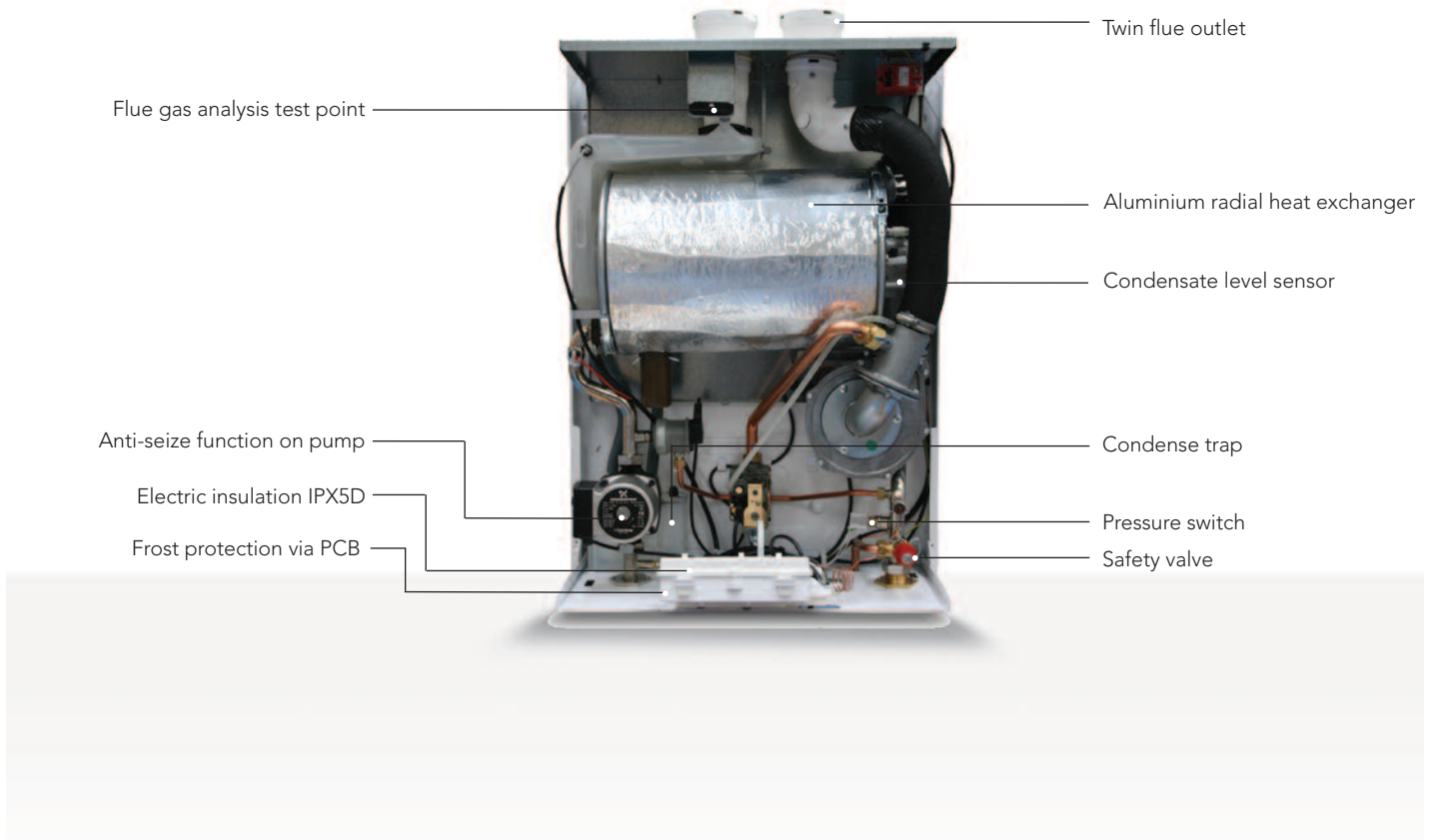

SPECIFICATIONS	Verve
Product order code	20039783
Central Heating	
Heat input (kW)	47
Maximum heat output (kW) 80/60°C	45.78
Maximum heat output (kW) 50/30°C	49.91
Weight	
Dry weight (kg)	39
Connections	
Flow and Return	1.0"
Gas	22mm
Safety Valve	15mm
Condense	21mm
Electrical	
Voltage (V/Hz)	230/50
Flue Details (concentric)	
Maximum horizontal flue length (60mm/100mm)	1.8m
Maximum vertical flue length (60mm/100mm)	2.8m
Maximum horizontal flue length (80/125mm)	4.8m
Maximum vertical flue length (80/125mm)	7.0m
Flue Details (twin pipes)	
Maximum horizontal flue length (80mm/80mm)	20m/20m
Maximum vertical flue length (80mm/80mm)	20m/20m
Efficiency	
Efficiency ⁽³⁾ (%)	90.1
NOx class	5

³SEDBUK 2005

DIMENSIONS AND CLEARANCES (MM)

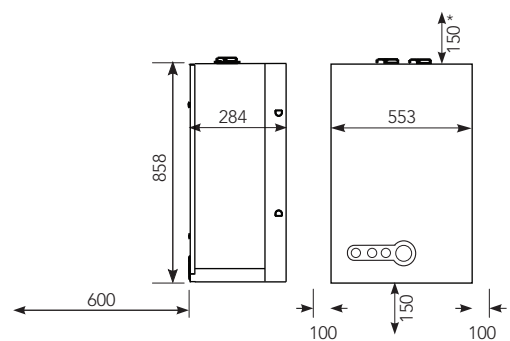

*From casing or 25mm above flue elbow (whichever is applicable)

HIGH POWER DOMESTIC BOILER

The Verve boiler has been designed to provide domestic installers the opportunity to expand their scope of work into large domestic and light commercial applications without having to gain additional commercial qualifications.

Domestic characteristics include Vokèra's unique in-house patented heat exchanger and a similar PCB to that of other Vokèra domestic appliances, ensuring a familiar and simple installation.

Mynute i

High efficiency system boiler

- UP TO 92.3% EFFICIENT ⁽¹⁾
- 5 year warranty ⁽²⁾
- REAR FLUE OPTION
- FRONT MOUNTED PATENTED HEAT EXCHANGER
- UP TO 8:1 MODULATION RATIO
- BUILT IN ON BOARD RELAY
- COMPATIBLE WITH SOLAR THERMAL

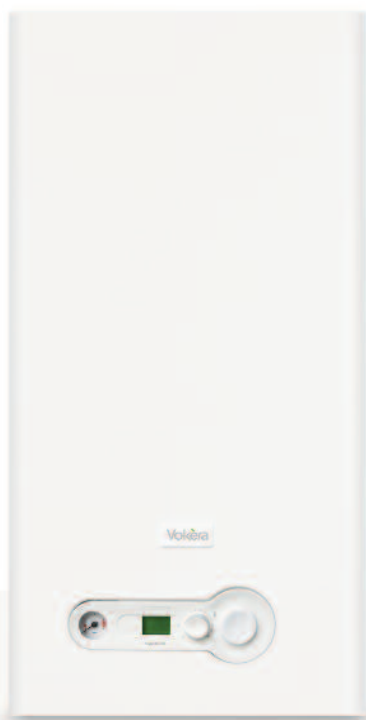

SEDBUK A rated and up to 92.3%⁽¹⁾ efficient when installed with the weather compensation sensor or OpenTherm control⁽¹⁾, reducing running costs by up to 35% more than a conventional boiler which helps to safeguard the environment.

5 year parts and labour warranty⁽²⁾.

High modulation ratio, 7:1 on Mynute i20 and 8:1 on Mynute i30, increasing efficiency and component longevity.

Simple to use back-lit LCD display ensures end-users can easily operate and adjust the appliance.

Rear flue option as well as the standard top flue option provides a versatile installation. Other flueing options available are; horizontal, vertical and twin flue.

Front mounted heat exchanger assists in simple maintenance. Our in-house patented heat exchanger incorporates a unique radial design utilising an extruded aluminium alloy. Aluminium has excellent thermal transfer properties and our updated design incorporates a new profile that inhibits the build-up of condense residues, thereby significantly reducing the frequency of cleaning.

Built-in relay enables the boiler to be used with external controls and switching voltages. The relay can also be reconfigured to incorporate an external weather compensation sensor in certain controls systems.⁽⁴⁾

Dual temperature range - easily configured to suit under-floor heating systems, with 2 built-in temperature ranges to suit either high or low temperature systems.

Low pressure loss reduces noise and increases pump performance.

Designed for easy installation with standard Vokèra pipework layout enabling trouble free replacement of older Vokèra models.

Simple commissioning, only minimal adjustments are required after installation and automatic modulation eliminates the need to range rate the boiler.

Low NOx - Class-5 performance.

Anti seize function protects the pump from sticking during long periods of inactivity.

Anti-cycling control prevents energy wasteful on/off cycling and reduces wear and tear.

Versatile horizontal or vertical flueing options – using Vokèra’s concentric or twin flue systems – enable the boiler to be sited almost anywhere in the home.

Standard Autostop disabling function⁽³⁾ that automatically changes the current operating mode and moves it permanently into the standby mode, helping Social Landlords fulfill their obligation of an annual gas safety check. Autostop will only operate after a pre-defined period of time has elapsed and if it has been activated during commissioning.

Built-in thermo-regulation, attach an energy saving control⁽⁴⁾ to increase energy efficiency. Compatible with weather compensation sensor and OpenTherm RF control.

Can be converted to LPG with LPG Kit.

Compatible with Vokèra’s MCS accredited Zenith Solar thermal collectors.

Compatible with Vokèra’s unvented single and twin coil cylinders.



OPTIONS

Description	Code
OpenTherm RF programmable room thermostat ⁽⁴⁾	20050690
Weather compensation sensor ⁽⁴⁾	2359259
Relay ⁽⁴⁾ (for use with weather compensation sensor)	29450144
Spacing frame	435
Mynute i LPG conversion kit	20069593
Pipe cover	518
Condense pump	404
Magnetic filter	29450199

⁽¹⁾When installed with a Vokèra intelligent control, as proposed in SAP 2005. ⁽²⁾Subject to registration and annual service. ⁽³⁾Autostop activation device required. ⁽⁴⁾Can be used on heat only appliances, contact Vokèra Technical Helpline for advice

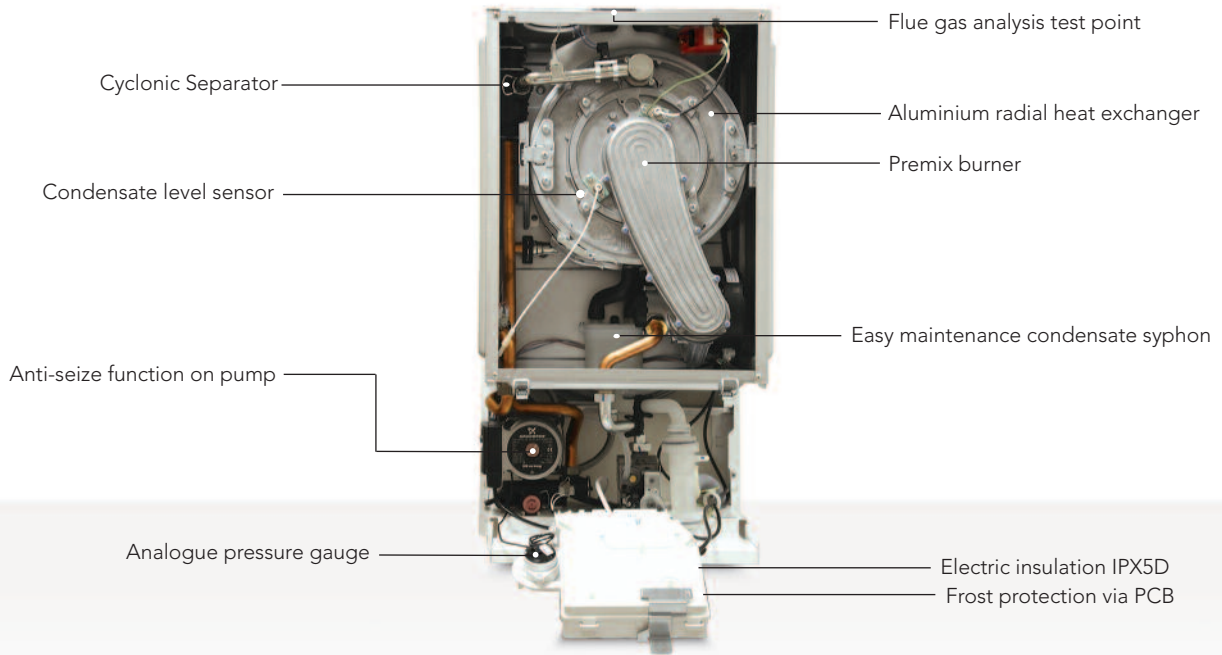

SPECIFICATIONS	Mynute i20	Mynute i30	Mynute i35 ⁽⁵⁾
Central Heating			
Heat input (kW)	20	30	TBC
Maximum heat output @ 80/60°C (kW)	2.76 - 19.62	3.5 - 29.25	TBC
Maximum heat output @ 50/30°C (kW)	3 - 21.44	3.8 - 31.77	TBC
Modulation ratio			
Modulation ratio @ 50/30C	7:1	8:1	TBC
Weight			
Dry weight (kg)	36	38	TBC
Clearances			
Sides	12mm	12mm	TBC
Top ⁽⁶⁾	150mm	150mm	TBC
Bottom	150mm	150mm	TBC
Front	600mm	600mm	TBC
Connections			
Flow and return	22mm	22mm	TBC
Gas	15mm	15mm	TBC
Safety valve	15mm	15mm	TBC
Condense	21mm	21mm	TBC
Flue Details (concentric)			
Maximum horizontal flue length inc. rear flue (60/100mm)	7.8m	7.8m	TBC
Maximum vertical flue length (60/100mm)	8.8m	8.8m	TBC
Maximum horizontal flue length (80/125mm)	18m	14m	TBC
Maximum vertical flue length (80/125mm)	20m	16m	TBC
Flue Details (twin pipes)			
Max horizontal (80mm/80mm)	45/45m	30/30m	TBC
Max vertical (80mm/80mm)	45/45m	30/30m	TBC
Efficiency			
Efficiency ⁽⁷⁾ (%)	90.30	90.03	TBC
NOx class	5	5	TBC

⁽⁷⁾ SEDBUK 2005

DIMENSIONS AND CLEARANCES (MM)

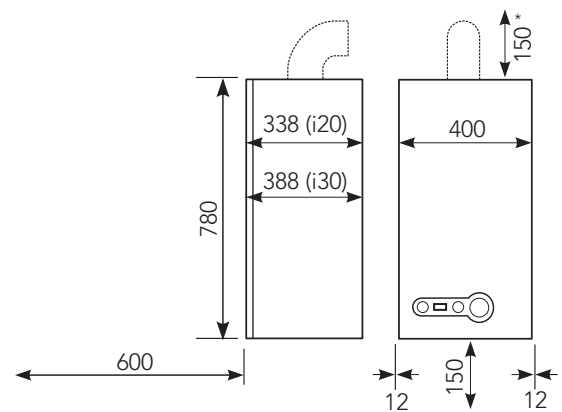

*From casing or 25mm above flue elbow (whichever is applicable)

EASY TO INSTALL AND SIMPLE TO MAINTAIN

The popular and respected Mynute HE range has been redeveloped to create the highly efficient Mynute i system boiler. The Mynute i is extremely energy efficient and is the first Vokèra system boiler to incorporate a wide modulation ratio, up to 8:1, which provides significant benefits to the end user with the primary advantages being running costs and user comfort.

The Mynute i is also the first Vokèra system boiler to incorporate a front mounted heat exchanger which ensures the range is easy to install and simple to maintain.



The versatile flue options simplify installation further and increase siting flexibility. Flue options include a rear flue option and horizontal or vertical flueing options, using Vokèra's concentric or twin flue systems.

⁽⁵⁾ Mynute i35 is launching soon, please order the Mynute 35HE in the meantime. Code 880

Vision S

High efficiency system boiler

UP TO
92.2%
EFFICIENT ⁽¹⁾

⁽²⁾
5 or 7 year warranty

BUILT IN
ON-BOARD
RELAY

REAR
FLUE
OPTION

KITCHEN
CUPBOARD FIT

LIGHTWEIGHT
FROM JUST
25KG



SEDBUK A rated and up to 92.2% efficient when installed with the weather compensation sensor or OpenTherm control⁽¹⁾, reducing running costs by up to 35% more than a conventional boiler which helps to safeguard the environment.

Built in on-board relay on Vision S enables the simplest of connections to enable Y plan compatibility, other 230V controls or energy saving controls, including weather compensation sensor.

NEW 5 or 7 year parts and labour warranty option.⁽²⁾

Small dimensions enable the boiler to be sited almost anywhere in the home, including a kitchen cupboard.



Rear flue option as well as the standard top flue option provides a versatile installation. Other flueing options available are; horizontal, vertical and twin flue.

Designed for easy installation with standard Vokera pipework layout enabling trouble free replacement of older Vokera models.

Lightweight at only 25kg for the 20S, enables the boiler able to be lifted into place easily even in tight spaces.

Low NOx - Class-5 performance. Only 21mg/kWhr for 20S provides maximum credits available for a condensing boiler under the Code for Sustainable Homes.

Pipe cover (not shown) available as an optional extra, for a tidy installation.

Standard Autostop disabling function⁽³⁾ automatically changes the current operating mode and moves it permanently into the standby mode, helping registered social landlords fulfill their legal obligation of an annual gas safety check. Autostop will only operate after a pre-defined period of time has elapsed and if it has been activated during commissioning.

Attach the outside weather compensation sensor or OpenTherm RF Programmable room thermostat to the Vision system boiler to further increase energy efficiency and comfort (heating only applications).⁽⁴⁾

Simple commissioning, only minimal adjustments are required after installation and automatic modulation eliminates the need to range rate the boiler.

Additional built in functions include: SARA function for automatic temperature control and improved efficiency, anti-cycling for longer lasting component performance and CO mode for simple servicing.

Built-in frost protection, protects the appliance from damage during periods of cold weather.

Low temperature option for under floor heating.

Can be converted to LPG with LPG kit.

Compatible with Vokera's unvented single and twin coil cylinders.

Compatible with Vokera's MCS accredited Zenith Solar thermal collectors.

Vision combi boiler also available, see page 18 for more information.

⁽¹⁾When installed with a Vokera intelligent control, as proposed in SAP 2005 ⁽²⁾ Subject to registration and annual service, 7 year warranty option available until 31st December 2014 ⁽³⁾ Autostop activation device required. Contact Vokera Technical Helpline for advice ⁽⁴⁾ Contact Vokera technical for advice ⁽⁵⁾ Required for use with OpenTherm and weather compensation controls

KITCHEN CUPBOARD FIT



ENERGY SAVING CONTROLS AND OPTIONS

Description	Code
Rear flue terminal	29450133
Pipe cover	20012594
RF Room thermostat control	20059642
OpenTherm RF programmable room stat ⁽⁴⁾	20050690
Weather compensation sensor ⁽⁴⁾	2359259
Spacing frame	20030704
Control interface ⁽⁵⁾	29450143
Magnetic filter	29450199

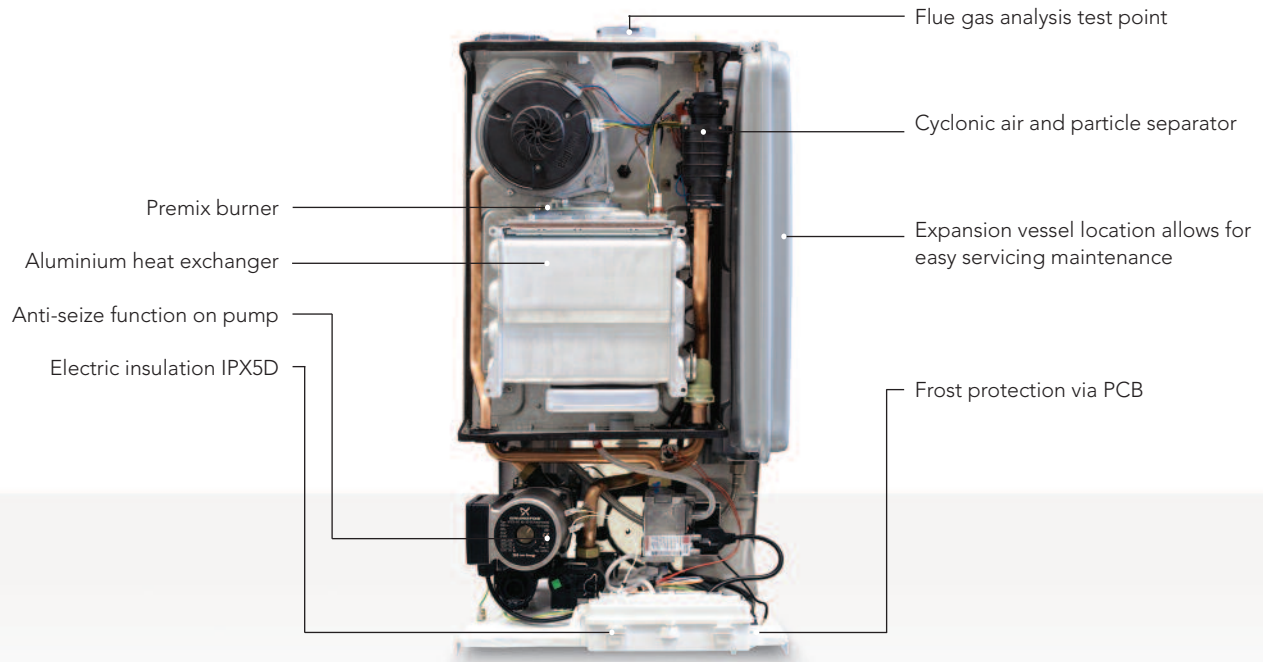

SPECIFICATIONS	Vision 20S	Vision 25S
Product order code - 5 year warranty	20071534	20071535
Product order code - 7 year warranty	29450433	29450434
Central Heating		
Heat input (kW)	20	25
Maximum heat output @ 80/60°C (kW)	19.5	24.45
Maximum heat output @ 50/30°C (kW)	20.84	26.23
Weight		
Dry weight (kg)	25	26
Connections		
Flow & return	22mm	22mm
Gas	15mm	15mm
Safety Valve	15 mm	15mm
Condensate	21mm	21mm
Electrical		
Voltage (V/Hz)	230/50	230/50
Flue details (concentric)		
Maximum horizontal flue length (60/100mm)	5.85m	4.85m
Maximum vertical flue length (60/100mm)	6.85m	5.85m
Maximum horizontal flue length (80/125mm)	15.3m	12.8m
Maximum vertical flue length (80/125mm)	16.3m	13.8m
Flue Details (twin pipes)		
Maximum horizontal flue length (80mm/80mm)	45m/45m	40m/40m
Maximum vertical flue length (80mm/80mm)	45m/45m	40m/40m
Efficiency		
Efficiency ⁽⁶⁾ (%)	90.1	90.2
NOx class	5	5

DIMENSIONS AND CLEARANCES (MM)

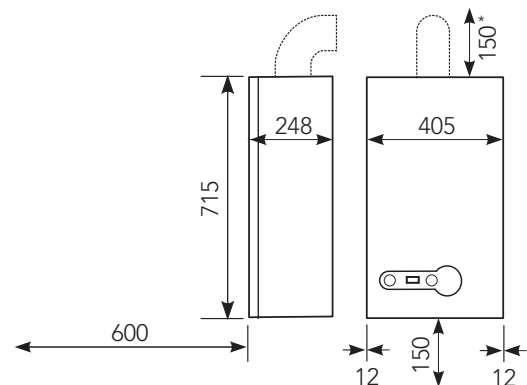

*From casing or 25mm above flue elbow (whichever is applicable)

INSTALLER FRIENDLY AND FEATURE RICH

The Vision range was designed to provide installers with a hassle free installation and end users with a simple to operate and reliable appliance.

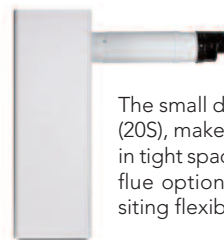

The small dimensions and lightweight 25kg lift weight (20S), make the Vision boilers very easy to install, even in tight spaces - including a kitchen cupboard. The rear flue option also simplifies installation and increases siting flexibility.

The upgraded Vision system boilers now come with a built in on-board relay which enables the simplest of connections to 230V controls and energy saving controls including the Vokèra weather compensation sensor.

⁽⁶⁾ SEDBUK 2005

Mynute VHE

High efficiency open vent boiler

- UP TO 90.5% EFFICIENT ⁽¹⁾
- 2 year warranty
- Energy Saving Trust recommended ⁽²⁾
- IN-HOUSE PATENTED HEAT EXCHANGER
- COMPATIBLE WITH SOLAR THERMAL
- KITCHEN CUPBOARD FIT ⁽²⁾



15kW model shown.



REAR FLUE AND TOP AND BOTTOM PIPE CONNECTIONS ⁽²⁾



⁽²⁾ 15kW outputs only. ⁽³⁾ Autostop activation device required. Contact Vokèra Technical for advice

SEDBUK A rated and up to 90.5% efficient⁽¹⁾, reducing running costs by up to 35% more than a conventional boiler which helps to safeguard the environment.

Energy Saving Trust Recommended certification mark (Mynute 15 VHE).

Aluminium heat exchanger provides excellent thermal transfer and anti corrosion properties and is fully recyclable.

Low pressure loss reduces noise and increases pump performance.

Simple commissioning, only minimal adjustments are required after installation and automatic modulation eliminates the need to range rate the boiler.

Low NOx - Class-5 performance.

Top and bottom pipe connections⁽²⁾ for flexibility and ease of installation.

Requires only 1-metre minimum static head.

Anti-cycling control reduces on/off cycling, increasing efficiency of the boiler and reducing fuel costs.

Built-in frost protection, protects the appliance from damage during periods of cold weather. External pump must be connected directly to the boiler to ensure this function operates.

Versatile, horizontal, vertical or rear flueing⁽²⁾ options enable the boiler to be sited almost anywhere in the home. Flue type certification also permits Mynute VHE to be used with Vokèra's 80mm PP Flexible flue liner and B23 applications.

Anti seize function protects the pump from sticking during long periods of inactivity.

Designed for easy installation with standard Vokèra pipework layout enabling trouble free replacement of older Vokèra models.

Compatible with Vokèra's MCS accredited Zenith Solar thermal collectors.

Standard Autostop disabling function⁽³⁾ automatically changes the current operating mode and moves it permanently into the standby mode, helping registered social landlords fulfill their legal obligation of an annual gas safety check. Autostop will only operate after a pre-defined period of time has elapsed and if it has been activated during commissioning.

Intuitive control panel ensures end-users can easily operate and adjust the appliance.

Purge cycle feature. Boiler will automatically run a two minute purge cycle when the boiler is switched on for the first time before the burner ignites to expel any air that may be present in the system.

Can be converted to LPG with LPG kit.

Compatible with Vokèra's unvented single and twin coil cylinders.

OPTIONS

Description	Code
Rear flue terminal (15kW only)	533
White pipe cover 400mm (20kW only)	518
Spacing frame (20kW only)	2359689
Condense pump	404
Magnetic filter	29450199

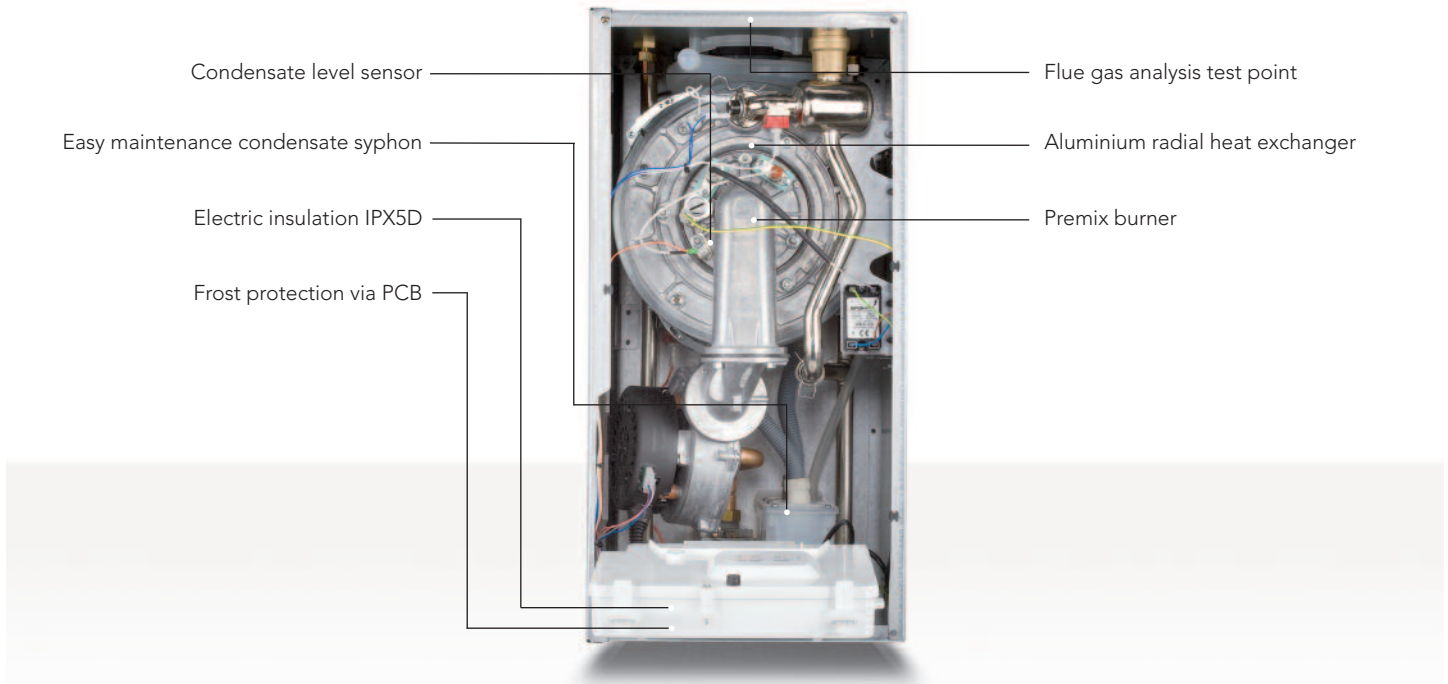

SPECIFICATIONS	Mynute 15VHE	Mynute 20VHE
Product order code	884	886
Central Heating		
Heat input (kW)	15	20
Maximum heat output @ 60/80°C (kW)	14.60	19.68
Maximum heat output @ 30/50°C (kW)	15.74	21.16
Min static head	1m	1m
Max static head	30m	30m
Min flow rate at max output	500 l/h	500l/h
Weight		
Dry weight (kg)	25	29
Connections		
Flow & return	22mm	22mm
Gas	15mm	15mm
Condense	21mm	21mm
Electrical		
Voltage (V/Hz)	230/50	230/50
Flue Details (concentric)		
Maximum horizontal flue length (60/100mm)	7.8m	7.8m
Maximum vertical flue length (60/100mm)	8.8m	8.8m
Maximum horizontal flue length (80/125mm)	25m	20m
Maximum vertical flue length (80/125mm)	30m	30m
Flue Details (twin pipes)		
Maximum horizontal flue length (80mm/80mm)	40m/40m	40m/40m
Maximum vertical flue length (80mm/80mm)	40m/40m	40m/40m
Efficiency		
Efficiency ⁽¹⁾ (%)	90.0	90.5
NOx Class	5	5

⁽¹⁾ SEDBUK 2005

DIMENSIONS AND CLEARANCES (MM)

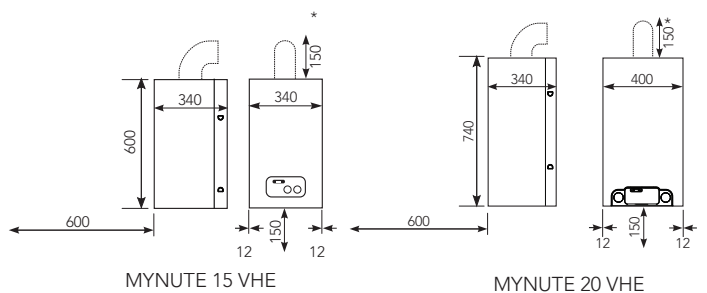

*From casing or 25mm above flue elbow (whichever is applicable)

CONTROL PANEL



No pipe cover available for 15kW outputs.
Pipe cover for 20kW output available as optional extra.

Need to upgrade your cylinder as well as your boiler?
You can install this boiler with a Vokera AquaFlow unvented single coil cylinder - See next page for details

AquaFlow

Unvented single coil water cylinder

FOR USE WITH
MYNUTE VHE,
MYNUTE i AND
VISION S BOILERS

2
year
warranty

WRAS
APPROVED

25 YEAR
GUARANTEE ON
INNER SHELL



For use with Vokera Mynute VHE open vent boiler, Mynute i system boiler and Vision S boiler.

Inner shell guaranteed for 25 years, made from Super-Molybdenum.

2 years guarantee on ancillary components.

High performance mains pressure to all hot water outlets.

Up to 50-litre per minute flow rate.

WRAS Approved.

Internal secondary expansion via self generating air gap means no expansion vessel required, or use fully flooded cylinder with an expansion vessel.

No need for 'sacrificial anode' due to excellent anti-corrosion properties of Super-Molybdenum.

Compact dimensions.

TPRV, EV, Tundish, 2-port motorised valve supplied as standard.

3kW immersion heater and energy cut-out device supplied as standard.

Optional secondary return connection if required.

Thermal insulation and energy efficient coil meet Part L Requirements.

SPECIFICATIONS	AquaFlow 150	AquaFlow 200	AquaFlow 250
Product order code	863	864	865
Capacity range	125-150 litres	170-200 litres	210-250 litres
Height	900mm	1150mm	1400mm
Depth (diameter)	580mm	580mm	580mm
Weight (when full)	190kg	240kg	300kg
Coil rating	12kW	26.5kW	26.5kW
Average recovery time	30 min	26 min	28 min
Energy loss (kW/day)	1.78	2.04	2.45
Maximum working pressure	8-bar	8-bar	8-bar

1. Hot water outlet
2. Pressure reducing valve
3. Expansion/check valve
4. Flexible connection
5. TPR valve
6. Tundish
7. Discharge pipe
8. Cylinder thermostat
9. Cold feed tube
10. Drain cock
11. Motorised valve
12. Flow connection
13. Junction box
14. Cable Entry
15. Commissioning drain valve
16. Secondary return
17. Return connection
18. Tee Piece
19. Immersion Element

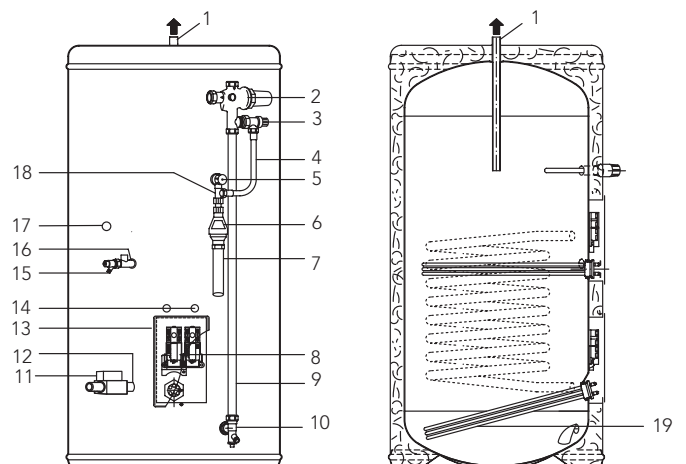

AquaNova

Instantaneous multipoint water heater

INSTANTANEOUS
HOT WATER

2
year
warranty

HIGH FLOW
RATE



Suitable for domestic and small light commercial applications.

Provides instant hot water to multiple outlets, such as to a kitchen and bathroom.

Ideal for replacement installations for properties that require hot water supply only due to existing electric, convector or gas wall heating appliances.

AquaNova has a 28kW heat output and high flow rate of 11.8 litres per minute.

Simple installation and commissioning. All connections are easily accessible and the appliance features a built-in fly lead.

Continuous gas modulation and electronic temperature sensing gives accurate temperature control.

AquaNova can be flued horizontally or vertically using Vokèra's concentric Uni flue or twin flue systems.

Simple to service. No diaphragm or water section. This reduces maintenance requirements.

Electronic ignition eliminates the need for a constantly running fan or energy wasteful pilot light.



SPECIFICATIONS	AquaNova	DIMENSIONS AND CLEARANCES (MM) - AQUANOVA
Product order code	965	
Rated output to DHW (kW)	28.8	
Hot water flow rate - 35°C rise (l/min)	11.8	
Dry weight (kg)	20	
Voltage (V/Hz)	230/50	
Power consumption (W)	85	
Minimum cold water inlet pressure	0.15 bar	
Maximum flue length		
Max horizontal flue length 60/100mm	2.4m	
Max vertical flue length 60/100mm	3.6m	
Max twin flue length 80/80mm	5m/5m + terminal	
Pipe connections		
DHW	15mm	
Cold water	15mm	
Gas	15mm	

*From casing or 25mm above flue elbow (whichever is applicable)

CondexaPRO and CondexaPRO Box

Stand alone, cascade and box units for commercial applications

CONDEXAPRO BOILER BACK TO BACK INSTALLATION



The CondexaPRO, a long established product range within Vokèra, makes true plant-room efficiency simple. The high reliability of products, the availability of a comprehensive line of specific accessories, the ease of mounting and the maximum flexibility, make the Vokèra CondexaPRO systems the best solution both for large domestic properties and commercial buildings, including hotels, schools, office-buildings, factories and sports centres. CondexaPRO products are suitable both for new buildings and as a replacement of old floor-standing boilers and offer the highest efficiency at any time combined with the maximum peace of mind, thanks to their modularity.

The availability of two different heat exchangers, giving nominal outputs of 50kW and 128kW, offer a number of practical boiler variations and even more cascade configurations, all available as natural gas or LPG.

The expert Vokèra Service team are also able to provide a commissioning service for CondexaPRO boiler installations.

CONDEXAPRO BOILERS

Possibility to combine CondexaPRO boilers in cascade systems to reach up to 3MW of total power.

CondexaPRO 50 M Master model - input from 15 to 50 kW (HHV), consists of one boiler unit and can work both as stand alone and in cascade applications with slave models.

CondexaPRO 100 M Master model - input from 15 to 100 kW (HHV), consists of two boiler units and can work both as stand alone and in cascade applications with slave models.

CondexaPRO 100 S Slave model - input from 15 to 100 kW (HHV), consists of two boiler units and can work only in cascade applications managed by a master model.

CONDEXAPRO BOX 500

Possibility to combine CondexaPRO Box 500 series in cascade systems to reach up to 3MW of total power.

CondexaPRO Box AI 500 - suitable for outdoor and indoor stand alone installations, includes shunt pumps. Available as 85M and 128M units.

CondexaPRO Box EXT 500 - suitable for outdoor cascade installations. Available as 150M and 200M units with shunt pumps or with two way valves. 100M expansion modular unit with shunt pumps also available.

CondexaPRO Box EXT AI 500 - suitable for outdoor stand alone installations, includes shunt pumps and hydraulic separator. Available as 250M and 300M units.

CondexaPRO Box INT 500 - suitable for indoor cascade installations. Available as 150M and 200M units with shunt pumps or with two way valves.

CONDEXAPRO BOX 1000

Possibility to combine CondexaPRO Box units (1000 series) in cascade systems to reach up to 6.9MW (NHV) of total power.

CondexaPRO Box AI 500 - suitable for outdoor and indoor stand alone installations. Available as 128kW units.

CondexaPRO Box EXT 1000 - suitable for external installations, includes shunt pumps. Available as 256kW, 364kW and 511kW units.

CondexaPRO Box INT 1000 - suitable for indoor cascade installations, includes shunt pumps. Available as 256kW, 384kW and 511kW units.

NB. 'AI' models are not suitable for cascade installations

CONDEXAPRO BOILER CASCADE INSTALLATION



CONDEXAPRO BOX INSTALLATION



CondexaPRO range

Ten reasons why it is the logical choice

MAXIMUM EFFICIENCY AT ALL TIMES.

The efficiency of a CondexaPRO and CondexaPRO Box is significantly higher than a traditional single boiler installation with the same output. In fact, by automatically controlling the number of boilers in operation, the system can optimise the heat supply according to demand at any particular time.

For instance in spring and autumn, when the heat request is lower, or in buildings like hotels and restaurants, where the heat request is not constant, the system can switch individual boilers on and off, ensuring maximum efficiency.

The CondexaPRO challenges the perception of fuel efficiency only being possible with low temperature systems. Traditionally it has been believed that condensing boilers only result in high fuel savings if installed with low temperature heating outputs (such as underfloor heating). Whilst this may be true for other condensing boilers with flue temperatures up to 25°C higher than the return temperature, the CondexaPRO's ability to keep flue temperatures as low as only 3°C above the return temperature makes the CondexaPRO ideal and highly efficient for both low temperature and high temperature heating outputs.

CONDEXAPRO CONDENSING BOILERS

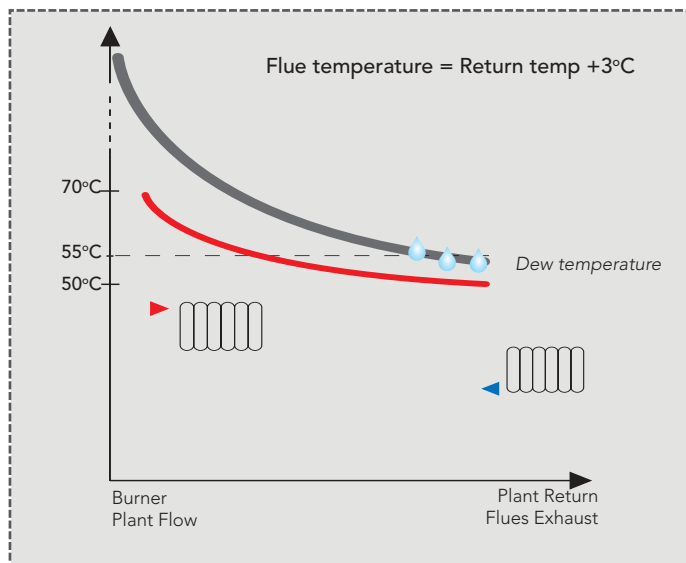

In high temperature plants (ex. 70°C / 50°C), the CondexaPRO boilers evacuate flue gases at a temperature lower than the natural gas flues dew, meaning that they work as a high efficiency condensing boiler. This is due to the low flue gas temperature of only 3°C above the return temperature.

MAXIMUM PEACE OF MIND.

A CondexaPRO system is more reliable than a traditional boiler installation as each boiler of the cascade can be individually serviced and maintained. In the event of a fault or maintenance on one combustion unit, the other boilers of the cascade are still able to operate without a total loss of heating.

MAXIMUM SAVINGS.

Thanks to the intelligent condensing technology of the CondexaPRO range, upgrading from an inefficient heating system to the high efficiency CondexaPRO will result in significant energy, fuel and financial savings. In addition, reduced installation time and quick servicing result in savings for the end user.

MAXIMUM EASE OF SERVICING.

The CondexaPRO range is designed so that all components can be easily serviced and maintained from the front. Each boiler can also be individually serviced and maintained while the other boilers of the cascade are still able to operate.

MAXIMUM COMMITMENT TO THE ENVIRONMENT.

The CondexaPRO range achieved Class 5 of the UNI EN 677 standard (best European category in ecological terms), thanks to the condensing combustion with controlled pre-mix burner and micro-flame burner combination. A CondexaPRO cascade can also automatically control the number of boilers in operation according to heat demand, saving energy and reducing polluting emissions.

MAXIMUM RANGE OF MODULATION.

CondexaPRO M (master model), 500 series boilers and box units contain a board that can manage up to 60 slaves in cascade and up to 3MW of power, with a modulation down to only 16kW. For larger commercial applications the CondexaPRO 1000 series has capabilities of up to 6.9MW, and can modulate down to 23kW. To configure multi-boiler cascades over 450kW, all components of the cascade must be accurately sized and selected with the help of a specialised design engineer.

MAXIMUM FLEXIBILITY.

A CondexaPRO system is designed to provide a space-saving and versatile solution for light commercial buildings or large domestic properties.

CondexaPRO boilers are available for wall hung and floor standing installations and CondexaPRO Box units are available for indoor and outdoor installations with a choice of the standard painted unit or a stainless steel case. There are also different models according to the connections of each thermal unit with shunt-pump or two-ways valve. This last case being suitable for those applications with a single primary circulation pump.

MAXIMUM INTELLIGENT CONTROL.

In some cases, the CondexaPRO hard wired remote control interface unit can replace the need for an expensive BMS (Building Management System) as it controls the functionality of the boiler in respect of different zones. Please contact Vokèra Pre-Sales for further advice and information.

MAXIMUM EASE OF INSTALLATION.

Both CondexaPRO boilers and CondexaPRO Box units are designed to ensure a simple installation. A CondexaPRO boiler cascade can be assembled in the boiler room which is useful in new build and refurbished plant rooms. Within the box units, the combustion groups are already assembled together with the water, gas, condense and flue manifolds.

The AI box models have the hydraulic separator fitted and connected in the same box as the combustion groups. The integrated flue collector helps to keep the total height of the installation to a compact dimension.

MAXIMUM RELIABILITY.

All components are assembled and tested in the factory ensuring maximum reliability. The multi-combustion configuration of most of the CondexaPRO Box units guarantees that the end user benefits from continuity of service at all times.

Vokèra has carefully selected an extensive range of high quality components and accessories to configure CondexaPRO Box units to ensure that all components of your cascade work in harmony with one another.

For more information on the Vokèra CondexaPRO range please email marketing@vokera.co.uk

Compact SE

Combi boilers for specialist applications

APPROVED
FOR USE WITH
SHARED FLUE
SYSTEMS



COMPACT
DIMENSIONS

COMPATIBLE
WITH VOKERA
'UNI-FLUE'
RANGE



DON'T DELAY - SE and U Duct boiler replacement legislation is changing in September 2015 when these appliances will no longer be manufactured.



CONTROLS AND FLUES

Description	Code
NEW 7 day RF programmable room thermostat	20059643
Compact SE spacing frame	20030704
Telescopic horizontal flue terminal	2359119
Horizontal flue terminal	2359029
Vertical flue terminal	2359039
45° bend (pair)	2359049
90° bend	2359059
0.75m extension	2359069
1.5m extension	2359079
Telescopic extension	2359089
Long joint clips	2359169
Standard joint clips	2359179
Magnetic filter	29450199

The Compact SE is a standard efficiency appliance that is to be used on applications where a condensing boiler is not suitable. Any boiler replacements that use a standard efficiency appliance must have been deemed exempt under the Building Regulations (England and Wales) and Building Standards (Scotland).

Certified and approved for use with Type C22 and C42, shared flue systems e.g. SE duct and U duct.

Compact dimensions and low lift weight enables a flexible installation with the boiler being able to be sited almost anywhere in the home.

'Tyco' socket provides a simple 'plug and play' connection for the 7 day RF programmable room thermostat.

Designed for easy installation. Standard Vokera pipe-work layout for trouble free replacement of older Vokera models and top mounted flue turrent can be rotated 360 degrees.

Compatible with Vokera current 'Uni-flue' range of flue accessories.

Built in SARA function for improved efficiency, anti-cycling for longer lasting component performance, frost protection and CO mode for simple servicing.

Can be converted to LPG with LPG kit.

SPECIFICATIONS	Compact 24SE	Compact 28SE
Product order code	20022436	20022803
Central Heating		
Heat input (kW)	25.8	30.2
Maximum heat output @ 60/80°C (kW)	23.94	28.24
Domestic Hot Water		
Maximum input	25.8	30.2
Flow rate 35°C rise (l/min)	9.8	11.6
Dimensions and Weight		
Height x width x depth (mm)	715 x 405 x 248	780 x 450 x 328
Dry weight (kg)	28	41
Clearances		
Sides	12mm	12mm
Top*	150mm	150mm
Bottom	150mm	150mm
Front	600mm	600mm
Connections		
Flow & return	22mm	22mm
Gas	15mm	15mm
DHW hot & cold	15mm	15mm
Safety valve	15mm	15mm
Electrical		
Voltage (V/Hz)	230/50	230/50
Flue Details (concentric)		
Maximum horizontal flue length (60/100mm)	4.25m	3.40m
Maximum vertical flue length (60/100mm)	5.25m	4.40m
Flue Details (twin pipes)		
Maximum horizontal flue length (80mm/80mm)	16m/16m	14m/14m
Maximum vertical length (80mm/80mm)	16m/16m	14m/14m
Efficiency		
Efficiency ⁽¹⁾ (%)	81.1	81.4
NOx class	3	3

⁽¹⁾ SEDBUK 2005 *From casing or 25mm above flue elbow (whichever is applicable)

Mynute SE

System boiler for specialist applications

APPROVED
FOR USE WITH
SHARED FLUE
SYSTEMS



COMPACT
DIMENSIONS

COMPATIBLE
WITH VOKERA
'UNI-FLUE'
RANGE



The Mynute SE is a standard efficiency appliance that is to be used on applications where a condensing boiler is not suitable. Any boiler replacements that use a standard efficiency appliance must have been deemed exempt under the Building Regulations (England and Wales) and Building Standards (Scotland).

Certified and approved for use with Type C22 and C42, shared flue systems e.g. SE duct and U duct.

Compact dimensions and low lift weight enable a flexible installation with the boiler able to be sited almost anywhere in the home.

Compatible with Vokera's unvented single and twin coil cylinders.

Compatible with Vokera's current 'Uni-flue' range of flue accessories.

Designed for easy installation with the standard Vokera pipework enabling a trouble-free replacement of older Vokera models.

Built-in SARA function for improved efficiency, anti-cycling for longer lasting component performance, frost protection and CO mode for simple servicing.

Can be converted to LPG with LPG kit.

DON'T DELAY - SE and U Duct boiler replacement legislation is changing in September 2015 when these appliances will no longer be manufactured.



FLUES AND ACCESSORIES

Description	Code
Mynute 24SE spacing frame	20030704
Telescopic horizontal flue	2359119
Horizontal flue terminal	2359029
Vertical flue terminal	2359039
45° bend (pair)	2359049
90° bend	2359059
0.75m extension	2359069
1.5m extension	2359079
Telescopic extension	2359089
Long joint clips	2359169
Standard joint clips	2359179
Magnetic filter	29450199

SPECIFICATIONS	Mynute 24SE
Product order code	20030333
Central Heating	
Heat input (kW)	25.80
Maximum heat output @ 60/80°C (kW)	23.94
Dimensions	
Height x width x depth (mm)	715 x 405 x 248
Dry weight (kg)	29
Clearances	
Sides	12mm
Top*	150mm
Bottom	150mm
Front	600mm
Connections	
Flow & return	22mm
Gas	15mm
Safety valve	15mm
Electrical	
Voltage (V/Hz)	230/50
Flue Details (concentric)	
Maximum horizontal flue length (60mm/100mm)	4.25m
Maximum vertical flue length (60mm/100mm)	5.25m
Flue Details (twin pipes)	
Maximum horizontal flue length (80mm/80mm)	16m/16m
Maximum vertical flue length (80mm/80mm)	16m/16m
Efficiency	
Efficiency ⁽¹⁾ (%)	81.1
NOx class	3

⁽¹⁾ SEDBUK 2005 *From casing or 25mm above flue elbow (whichever is applicable)

Domestic Boiler Feature Reference Chart

Use this product feature reference chart to quickly identify what Vokera product provides the ideal solution for your heating and domestic hot water requirements.

PRODUCT FEATURES									
Feature	Linea One	Unica i	Unica BHE	Vision Combi	Compact A	Verve 47kW	Mynute i	Vision System	Mynute VHE
5 year warranty	✓	✓	✗	✓	✗	✗	✓	✓	✗
Back lit LCD display	✓	✓	✗	✓	✓	✓	✓	✓	✗
History recall information function	✓	✓	✗	✓	✗	✓	✗	✗	✗
DHW preheat ON/OFF function	✓	✓	✓	✓	✓	✗	✗	✗	✗
External second pump connection	✓	✗	✗	✗	✗	✗	✗	✗	✗
DHW memory function option	✓	✗	✗	✗	✗	✗	✗	✗	✗
DHW comfort function option	✓	✗	✗	✗	✗	✗	✗	✗	✗
Modulating pump	✓	✗	✗	✗	✗	✗	✗	✗	✗
Advanced Autostop function - 4 modes operation	✓	✗	✗	✗	✗	✗	✗	✗	✗
Autostop function - 1 mode operation	✗	✓	✓	✓	✓	✗	✓	✓	✓
OpenTherm control option	✓	✓ ⁽¹⁾	✓	✓ ⁽²⁾	✓ ⁽²⁾	✓ ⁽²⁾	✓ ⁽²⁾	✓ ⁽²⁾	✗
Cyclonic air and particle separator	✓	✓	✓	✓	✓	✓	✓	✓	✓
Built in filling loop	✓	✓	✗	✓	✗	✗	✗	✗	✗
Pre-heated hot water	✓	✓	✓	✓	✓	✗	✗	✗	✗
Pre-fixing jig	✓	✓	✗	✗	✗	✗	✗	✗	✗
Full hot water flame modulation +/- 1°C max fluctuation	✓	✓	✓	✓	✓	✗	✗	✗	✗
Automatic by-pass	✓	✓	✓	✓	✓	✗	✓	✓	✗
Digital diagnostic code display	✓	✓	✓	✓	✓	✓	✓	✓	✓
High efficiency air/gas modulation system	✓	✓	✓	✓	✓	✓	✓	✓	✓
Weather compensation control option	✓ ⁽³⁾	✓	✓	✓ ⁽²⁾	✓ ⁽²⁾	✓ ⁽²⁾	✓ ⁽²⁾	✓ ⁽²⁾	✗
Compartment ventilation not required	✓	✓	✓	✓	✓	✓	✓	✓	✓
Built in frost protection	✓	✓	✓	✓	✓	✓	✓	✓	✓
LPG model / conversion kit available	✓	✓	✓	✓	✓	✓	✓	✓	✓
Anti seize function	✓	✓	✓	✓	✓	✓	✓	✓	✓
'Anti cycle' heating control	✓	✓	✓	✓	✓	✓	✓	✓	✓
Electrical insulation to IPX5D	✓	✓	✓	✓	✓	✓	✓	✓	✓
Fault diagnostic display	✓	✓	✓	✓	✓	✓	✓	✓	✓
Telescopic flue system	✓	✓	✓	✓	✓	✓	✓	✓	✓
Twin flue system	✓	✓	✓	✓	✓	✓	✓	✓	✓
Vertical flue option	✓	✓	✓	✓	✓	✓	✓	✓	✓
Rear flue option	✗	✓	✗	✓	✓	✗	✓	✓	✓ ⁽⁴⁾
Combustion analysis function	✓	✓	✓	✓	✓	✓	✓	✓	✓
Electronic burner ignition	✓	✓	✓	✓	✓	✓	✓	✓	✓
Pipe space through back of boiler	OPT	OPT	✗	OPT	OPT	✗	OPT	OPT	N/A
Domestic heat exchanger: 5yr guarantee against scaling of DHW	✓	✓	✓	✓	✓	N/A	N/A	N/A	N/A

⁽¹⁾ Plug and Play connection on OpenTherm and Unica i

⁽²⁾ Contact Vokera Technical for advice

⁽³⁾ Weather compensation control supplied as standard

⁽⁴⁾ Mynute 15VHE only

Flue Options

Vokèra offer a wide range of flue systems that are able to meet the majority of applications. There are concentric flue systems and a parallel (twin) flue system that can be used in either horizontal or vertical configurations.

All Vokèra flue systems incorporate simple to use, push-fit connections that are designed to enable a fast and simple method of installation. The attractive white finish complements the modern design of our appliances.

60/100mm CONCENTRIC

Our 60/100 condensing range (for HE appliances) are the most widely used and will suit most applications that are usually encountered.

80/125mm CONCENTRIC

The 80/125 range is suitable for use on specific appliances and suits applications where a slightly longer concentric flue system is required.

80mm + 80mm PARALLEL (twin)

The 80mm + 80mm parallel (twin) range can be utilised where an extremely long flue run is envisaged, or required.

Uni-flue 60/100mm CONCENTRIC

The Uni-flue range is suitable for use on the Aquanova water heater and standard efficiency appliances that are only to be used on applications where a condensing boiler is not suitable.

TERMINAL POSITIONS

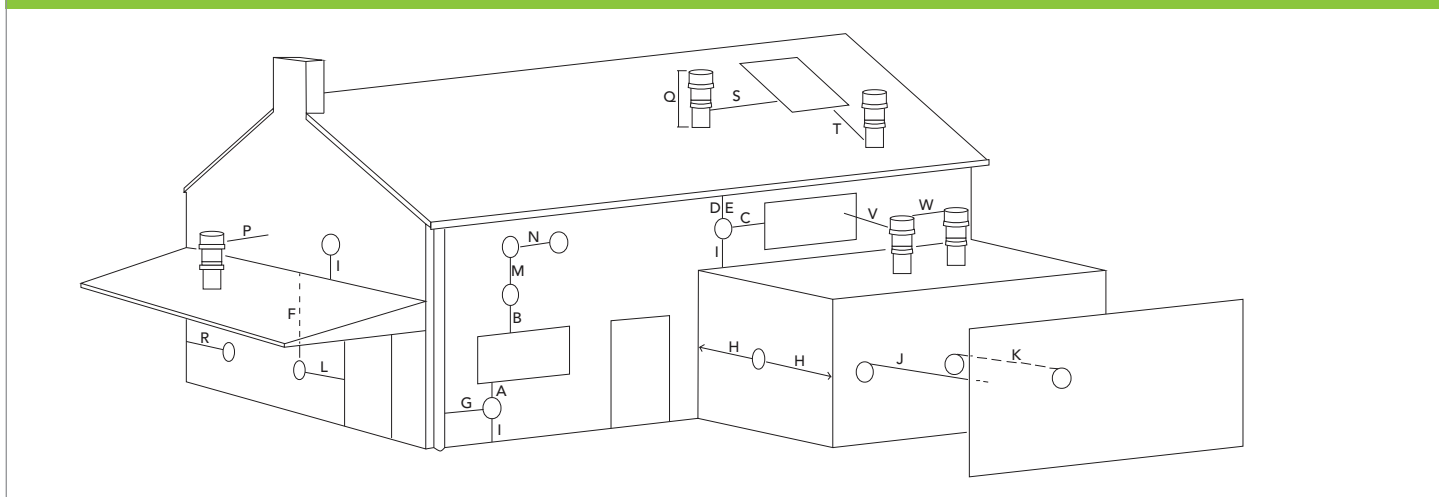

FLUE EXIT CLEARANCES

	Flue Exits	Minimum distance SE & HE Boilers
A	Below an opening*	300mm
B	Above an opening*	300mm
C	To the side of an opening*	300mm
D	Below gutters, drain pipe etc	25mm
E	Below eaves	25mm
F	Below balcony, carport roof etc	25mm
G	To side of a vertical soil/drain pipe etc	25mm (60mm for 80/125 flue)
H	From internal or external corner or boundary	25mm (60mm for 80/125 flue)
I	Above ground, roof or balcony level	300mm
J	From a surface or boundary facing a terminal	600mm**
K	From a terminal facing a terminal	1200mm
L	From an opening in the carport into the building	1200mm
M	Vertically from a terminal on the same wall	1500mm
N	Horizontally from a terminal on the same wall	300mm
P	From a structure to the side of a vertical terminal	300mm
Q	From the top of a vertical terminal to the roof flashing	As determined by fixed collar of vertical terminal
R	To the side of a boundary	300mm
S	To the side of an opening / window on a pitched roof	600mm
T	Below an opening / window on a pitched roof	2000mm
V	From a vertical terminal to an adjacent opening*	Call Vokèra Technical for advice
W	From a vertical terminal to an adjacent vertical terminal	300mm (only if both terminals are same height)

Flue systems and terminal locations should be located and installed in accordance with current Building Regulations (UK) or I.S. 813 (ROI).

The terminal should be located where the dispersal of combustion products is not impeded and with due regard for the damage and/or discolouration that may occur to building products located nearby.

The terminal must not be located in a place where it is likely to cause a nuisance. Water vapour may condense on leaving the terminal. The effect of such plumeing must be considered.

* Term 'opening' includes window, air brick etc

** Minimum clearance ensures the boiler works safely, however consideration should be made for nuisance factor.

Flue Options

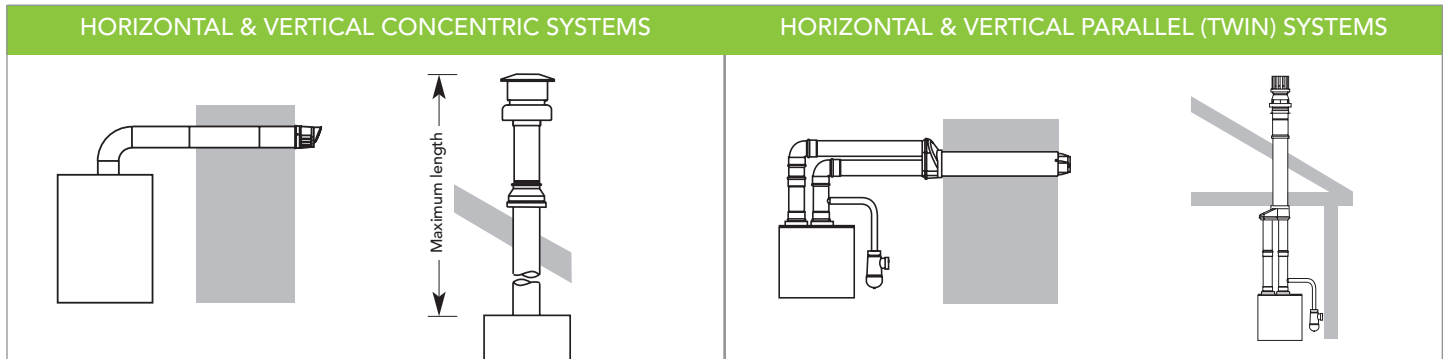

ALSO AVAILABLE - 80MM FLEXIBLE PP FLUE SYSTEM

The 80mm Flexible PP Flue System range consists of Polypropylene components and a flexible Polypropylene liner. A full range of flue components and accessories to facilitate different flue requirements are available.

The flexible PP flue system is suitable for multiple applications and is for use with high efficiency appliances, including Linea One, Unica i, Vision Combi and System boilers, Mynute i, Mynute VHE and Compact A.

The range includes several different connectors that enable flexible PP to be connected to rigid PP / flexible PP to flexible PP when off-cuts may be required to be joined together.

For further information and advice please contact the Vokera Technical Helpline on 0844 391 0999 (option 4).

MAXIMUM FLUE LENGTHS

	Concentric 60/100mm (4")		Concentric 80/125mm (5")		Parallel (twin) 80mm + 80mm	Flexible PP Flue	Concentric Uni-flue 60/100mm (4")	
	Horiz.	Vertical	Horiz.	Vertical	Horiz. / Vertical	Horiz. / Vertical	Horiz.	Vertical
Linea One	3.85m	4.85m	10.0m	12.0m	30m + 30m	12m + 12m	N/A	N/A
Unica i28	7.8m*	8.8m*	18m	20m	45m + 45m	16m + 16m	N/A	N/A
Unica i32	7.8m*	8.8m*	18m	20m	45m + 45m	14m + 14m	N/A	N/A
Unica i36	7.8m*	8.8m*	18m	20m	45m + 45m	14m + 14m	N/A	N/A
Unica Balcony HE	7.8m	8.8m	20m	25m	40m + 40m	16m + 16m	N/A	N/A
Vision 25C	5.85m*	6.85m*	15.3m	16.3m	45m + 45m	8m + 8m	N/A	N/A
Vision 30C	4.85m*	5.85m*	12.8m	13.8m	40m + 40m	8m + 8m	N/A	N/A
Compact 25A	5.85m*	6.85m*	15.3m	16.3m	45m + 45m	8m + 8m	N/A	N/A
Compact 29A	4.85m*	5.85m*	12.8m	13.8m	40m + 40m	8m + 8m	N/A	N/A
Compact 24SE	N/A	N/A	N/A	N/A	16m + 16m	N/A	4.25m	5.25m
Compact 28SE	N/A	N/A	N/A	N/A	14m + 14m	N/A	3.40m	4.40m
Verve 47kW	1.8m	2.8m	4.8m	7.0m	20m + 20m	8m + 8m	N/A	N/A
Mynute i20	7.8m	8.8m	20m	25m	40m + 40m	16m + 16m	N/A	N/A
Mynute i30	7.8m	8.8m	20m	25m	40m + 40m	16m + 16m	N/A	N/A
Mynute i35	7.8m	8.8m	20m	25m	40m + 40m	16m + 16m	N/A	N/A
Mynute 35HE	7.8m	8.8m	20m	25m	40m + 40m	16m + 16m	N/A	N/A
Vision 20S	5.85m	6.85m	15.3m	16.3m	45m + 45m	8m + 8m	N/A	N/A
Vision 25S	4.85m	5.85m	12.8m	13.8m	40m + 40m	8m + 8m	N/A	N/A
Mynute 15VHE	7.8m	8.8m	25m	30m	40m + 40m	16m + 16m	N/A	N/A
Mynute 20VHE	7.8m	8.8m	20m	25m	40m + 40m	16m + 16m	N/A	N/A
Mynute 24SE	N/A	N/A	N/A	N/A	16m + 16m	N/A	4.25m	5.25m
Aquanova	N/A	N/A	N/A	N/A	7m + 7m	N/A	2.4m	3.8m
Reductions for additional bend/s (reduction for PMK = 4.0 metres)								
45-deg	1m	1m	1m	1m	1m	N/A	1m	1m
90-deg	1m	1m	1m	1m	1m	N/A	1.5m	1.5m

*Deduct 3.85m from the maximum flue length when installed with Fuelsaver.



80MM PARALLEL (TWIN) FLUE SYSTEMS

Code	Description
310	Adaptor kit for SE range and Aquanova
430	Adaptor kit for all condensing boilers
0225805	Horizontal terminal & convertor box
0225810	Vertical terminal & convertor box
0225820	250mm extension (pair)
0225825	500mm extension (pair)
0225830	1000mm extension (pair)
0225835	2000mm extension (pair)
0225840	45-deg bend (pair)
0225845	90-deg bend (pair)
0225850	Double pipe bracket 80mm X 80mm (5-OFF)
0225855	Single pipe bracket 80mm (5-OFF)
0225765	Flat roof flashing plate (390mm Dia)
29450178*	Condense trap kit for SE range and Aquanova
29450176	Vertical collector for SE range and Aquanova
29450177	Horizontal collector for SE range and Aquanova

*When ordering this product you will need to also order either the 29450176 or 29450177, depending on your installation requirements.

The 80mm + 80mm parallel (twin) system enables greater flue lengths to be achieved and can be used in either a horizontal or vertical configuration. However the parallel system must be converted back to a concentric system at the point of termination. Dedicated flue kits are available for this purpose.

An adaptor kit is required to convert the appliance flue outlet from a concentric configuration into a parallel configuration.

When used in the horizontal plane, the flue system should be installed so that it has a 1° – minimum – fall back to the boiler. This will enable any condensate fluid that may form, to drain via the condensate connection/trap.

The exhaust pipe can reach very high temperatures and so must be adequately protected to avoid contact with persons and/or materials that could be damaged as a result.

The air inlet pipe should be insulated to reduce the possibility of condense forming on the outside of the pipe.

Vokèra can advise that the Gas Safe Technical Bulletin, TB 008 ed2.1, gives specific advice on the requirements for new installations with a flue routed within a void, where appropriate means for the gas engineer to visually check the flue must be incorporated (this is normally achieved by inspection hatches located in the ceiling).

The flue system installation options as detailed below are not generic for all concentric flues. Please see the boiler and flue compatibility tables for information on a specific appliances suitability with the different concentric flue systems.

FLUE SYSTEM OPTIONS

Configuration	Description	Compatible with
1	Horizontal Concentric	All appliances
2	Vertical Concentric	All appliances
3	Horizontal parallel system	All appliances
4	Vertical parallel system	All appliances

N.B. A boiler top adaptor/kit is required when using the 80/125mm concentric and 80mm parallel systems.

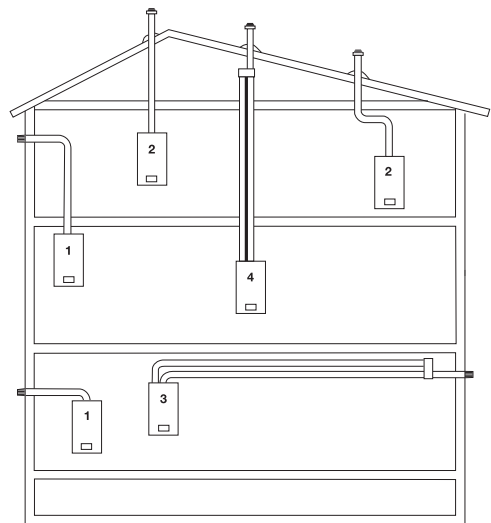

White nose cone
60/100mm concentric flue system
Code: 29450130



Telescopic horizontal flue terminal
60/100mm concentric flue system
Code: 29450121



Plume management kit
60/100mm concentric flue system
Code: 522

Boiler and Flue Compatibility

Concentric flue ranges

The **60/100 condensing range** is suitable for all current Vokèra high efficiency (condensing) appliances. A flue kit adaptor is required to use the 60/100 concentric flue on the Verve 47kW domestic heat only boiler.

When used in the horizontal plane, the flue system (excluding horizontal terminal) should be installed so that it has a 1° - 3° fall back to the boiler (17mm - 51mm per-metre). This will enable any condensate fluid that may form, to drain via the condensate connection/trap. It can also be used as a replacement flue system on older/obsolete Vokèra HE appliances, however you should contact the Vokèra Technical Helpline for specific advice.

60/100MM CONCENTRIC FLUE SYSTEMS

Code	Description	Linea One	Unica i	Unica BHE	Vision range ⁽¹⁾	Compact A	Verve 47kW	Mynute i	Mynute VHE
29450121	Telescopic horizontal flue terminal	✓	✓	✓	✓	✓	✓	✓	✓
29450120	Horizontal flue terminal	✓	✓	✓	✓	✓	✓	✓	✓
522	Plume management kit	✗ ⁽²⁾	✓	✓	✓	✗ ⁽²⁾	✗	✓	✓
29450131	Plume management kit extension	✗ ⁽²⁾	✓	✓	✓	✗ ⁽²⁾	✗	✓	✓
29450123	90-deg bend	✓	✓	✓	✓	✓	✓	✓	✓
29450124	45-deg bend (pair)	✓	✓	✓	✓	✓	✓	✓	✓
29450125	500mm extension	✓	✓	✓	✓	✓	✓	✓	✓
29450126	1000mm extension	✓	✓	✓	✓	✓	✓	✓	✓
29450127	2000mm extension	✓	✓	✓	✓	✓	✗	✓	✓
29450128	Telescopic extension	✓	✓	✓	✓	✓	✓	✓	✓
529	Wall brackets (5 x 100mm)	✓	✓	✓	✓	✓	✓	✓	✓
29450122	Vertical flue terminal	✓	✓	✓	✓	✓	✓	✓	✓
531	Pitched roof flashing plate	✓	✓	✓	✓	✓	✓	✓	✓
532	Flat roof flashing plate	✓	✓	✓	✓	✓	✓	✓	✓
533	Telescopic rear flue	✗	✗	✗	✗	✗	✗	✓	✓ ⁽³⁾
29450133	Telescopic rear flue	✗	✓	✗	✓	✓	✗	✓	✓ ⁽³⁾
534 ⁽⁴⁾	Brick red nose cone	✓	✓	✓	✓	✓	✓	✓	✓
535 ⁽⁴⁾	Beige nose cone	✓	✓	✓	✓	✓	✓	✓	✓
29450130	White nose cone	✓	✓	✓	✓	✓	✓	✓	✓
487	45-deg-plume diverter	✓	✓	✓	✓	✓	✓	✓	✓
20028027	Flue kit adaptor for Verve	✗	✗	✗	✗	✗	✓	✗	✗

⁽¹⁾Includes both Vision combi and system boilers ⁽²⁾Contact Vokèra Technical for advice ⁽³⁾15kW output only ⁽⁴⁾Available as special order only. Minimum order quantities apply

The **80/125 range** can be only utilised with certain appliances. A flue kit adaptor is required to use the 80/125 concentric flue on the Verve 47kW domestic heat only boiler. An adaptor is also required for other appliances to convert the flue outlet from 100mm to 125mm.

When used in the horizontal plane, the flue system (excluding horizontal terminal) should be installed so that it has a 1° - 3° fall back to the boiler (17mm - 51mm per-metre). This will enable any condensate fluid that may form, to drain via the condensate connection/trap.

80/125MM CONCENTRIC FLUE SYSTEMS

Code	Description	Linea One	Unica i	Unica BHE	Vision range ⁽¹⁾	Compact A	Verve 47kW	Mynute i	Mynute VHE
413	Horizontal terminal	✓	✓	✓	✓	✓	✓	✓	✓
414	Vertical terminal	✓	✓	✓	✓	✓	✓	✓	✓
415	90-deg bend	✓	✓	✓	✓	✓	✓	✓	✓
416	45-deg bend (single)	✓	✓	✓	✓	✓	✓	✓	✓
417 ⁽²⁾	250mm extension	✓	✓	✓	✓	✓	✓	✓	✓
418	500mm extension	✓	✓	✓	✓	✓	✓	✓	✓
419	1000mm extension	✓	✓	✓	✓	✓	✓	✓	✓
420	2000mm extension	✓	✓	✓	✓	✓	✓	✓	✓
422 ⁽²⁾	Telescopic extension	✓	✓	✓	✓	✓	✓	✓	✓
423	Wall brackets (5 x 125mm)	✓	✓	✓	✓	✓	✓	✓	✓
424	Boiler top adaptor for HE appliances	✓	✓	✓	✓	✓	✗	✓	✓
425 ⁽²⁾	Fixed offset	✓	✓	✓	✓	✓	✓	✓	✓
426	Silicon lubricant	✓	✓	✓	✓	✓	✓	✓	✓
532	Flat roof flashing plate	✓	✓	✓	✓	✓	✓	✓	✓
531	Pitched roof flashing plate	✓	✓	✓	✓	✓	✓	✓	✓
20028029	Flue kit adaptor for Verve	✗	✗	✗	✗	✗	✓	✗	✗

⁽¹⁾Includes both Vision combi and system boilers ⁽²⁾Available by special order



Choosing the right control

Intelligent controls

Maximise energy and fuel savings

With the introduction of condensing technology, boilers have continued to increase in efficiency with most current appliances able to reach over 90% efficiency. However, the technology within boilers is now so advanced that, even with future developments, there is little chance of boiler efficiency percentages increasing much further.

The one area that can still help maximise the efficiency and overall performance of the boiler is the correct use of a control. Even with average efficiencies now reaching over 90%, this can be increased by a further 2% - with the simple addition of a weather compensation control for example.

Choosing the right control

There are a number of different controls available so establishing the most suitable one for your heating requirements may be confusing. Vokèra provide a range of controls that can be used with combi and system boilers, including room thermostats, programmable room thermostats and the Vokèra 'Intelligent Control' range that incorporates the most advanced technology available, such as weather compensation and OpenTherm.

The Vokèra Vision Combi boilers come with a built in 7 day digital clock which enables different settings for each day of the week. Additional controls can be added to a Vision Combi if it needs to be sited in a difficult to access location or for energy saving purposes.

Intelligent controls

Outside weather compensation sensor

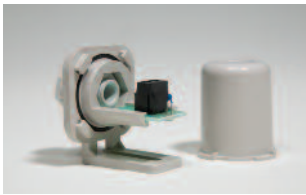

The Vokèra outside weather compensation sensor manages the central heating flow outlet temperature by regulating the boiler in line with external weather conditions, providing a consistent and comfortable room temperature. For example, when the central heating is timed to come on, the external sensor measures the outside temperature and the boiler calculates the required flow temperature needed to maintain the set room temperature.

Code: 2359259 - This control is supplied as standard with the Linea One combi boiler.

OpenTherm RF programmable room thermostat

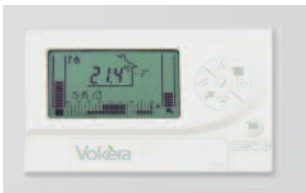

Vokèra's OpenTherm programmable room thermostat incorporates the most advanced technology; the basic principle of OpenTherm is that it takes over the management of the flow outlet temperature and raises or lowers the flow temperature of the boiler in order to maintain a certain room temperature that has been requested or set by the end user.

When you connect the OpenTherm to a boiler, the boiler's own internal management of the set point becomes redundant and the OpenTherm control takes over. By allowing the OpenTherm to manage the set-point the efficiency of the appliance is increased as the control constantly endeavours to maintain a

low outlet temperature, this means an even lower return temperature and condensing boilers are at their peak efficiency when operating with a low return temperature.

A saving of around 15% can be achieved when using the OpenTherm programmable room thermostat when compared to a typical ON/OFF room thermostat, this equates to a £67 saving on an annual fuel bill (energy saving based on average 18,000kw hrs per annum). Not only is the OpenTherm designed to reduce fuel costs it is also designed to improve end user comfort, it achieves this by significantly reducing or eliminating temperature 'undershoot' or 'overshoot', meaning that a stable room temperature is achieved and maintained.

You can install the OpenTherm alongside the weather compensation control to benefit from even further energy savings. Weather compensation technology 'fine tunes' the heating system to the outside temperature condition, where the flow temperature increases/decreases in response to external weather conditions. Effectively it takes into consideration the external temperature and works with the OpenTherm control to tell the boiler what it needs to do to compensate for the outside weather conditions, so if it is a warm day, it tells the boiler it will not need to work as hard to achieve the room set point.

Configured for use with the Unica i combi boiler with the receiver being easily connected to the boiler using the 'plug and play' Tyco socket. The Tyco connection can be re-configured or removed to facilitate use with other compatible Vokèra high efficiency combi boilers.

OpenTherm RF programmable room thermostat - colour white. Code: 20050690 (Black version also available. Code: 20050691)



Gas Safe Registered Installers: For a step by step installation video visit the Vokèra YouTube channel (search Vokera Ltd)

Choosing the right control

Energy saving controls

Energy Saving Controls

Room thermostats control the ambient room heating temperature. Programmable room thermostats can have different set temperatures for different periods of the day, offering greater flexibility and a simple solution to boiler control. For maximum comfort it is recommended that your thermostat is set between 18 - 21°C.

7 day RF programmable room thermostat



This ON/OFF programmable room thermostat allows easy control over boiler heating timings and temperatures over a 7 day period. A typical heating programme is pre programmed so the time and day of the week only need to be set before the programmer is fully operational.

Configured for use with the Compact A combi boiler with the receiver being easily connected to the boiler using the 'plug and play' Tyco socket. The Tyco connection can be re-configured or removed to facilitate use with other compatible Vokera high efficiency combi boilers.



Wireless version product code: 20059643

Hard-wired version also available, product code: 20063874

Tyco connection from receiver to boiler

RF room thermostat control

This ON/OFF room thermostat has similar characteristics to the above as it can be used to adjust the set room temperature. It is ideal for the Vision Combi boilers as it allows easy control over the heating temperatures but it will not interfere with any programmed heating timings that have been set on the built in digital clock.

Wireless version product code: 20059642

Hard-wired version also available, product code: 20063869

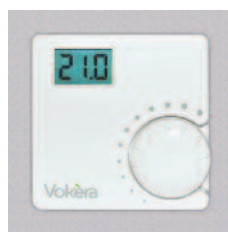

CONTROLS COMPATIBILITY

Code	Control	Linea One	Unica i	Unica BHE	Vision Combi	Compact A	Verve 47kW	Mynute i	Vision System	Mynute VHE
20050690	OpenTherm RF programmable room thermostat	✓ ⁽¹⁾	✓	✗ ⁽⁴⁾	✓ ⁽³⁾	✓ ⁽³⁾	✓ ⁽²⁾	✓ ⁽²⁾	✓ ⁽²⁾	✗
2359259	Outside weather compensation sensor	✓ ⁽⁵⁾	✓	✓	✓ ⁽³⁾	✓ ⁽³⁾	✓ ⁽²⁾	✓ ⁽²⁾	✓ ⁽²⁾	✗
20059643	7 Day RF Programmable room thermostat	✓	✓ ⁽⁶⁾	✗ ⁽⁴⁾	✓	✓	✓ ⁽²⁾	✓ ⁽²⁾	✓ ⁽²⁾	✓ ⁽²⁾
20063874	7 Day HW Programmable room thermostat	✓	✓	✗ ⁽⁴⁾	✓	✓	✓ ⁽²⁾	✓ ⁽²⁾	✓ ⁽²⁾	✓ ⁽²⁾
20059642	RF room thermostat control	✓	✓	✓	✓	✓	✓	✓	✓	✓
20063869	Hard-wired room thermostat control	✓	✓	✓	✓	✓	✓	✓	✓	✓
20025085	Compact A 24 hour analogue clock kit ⁽⁷⁾	✗	✗	✗	✗	✓	✗	✗	✗	✗

⁽¹⁾ Requires wiring kit - code 1221179 - contact Vokera Technical for advice.

⁽²⁾ Can be used on heating only applications - contact Vokera Technical for advice.

⁽³⁾ Requires control interface - code 29450143 - contact Vokera Technical for advice. The addition of an energy saving control will override any settings that have been programmed into the built in digital clock on the Vision Combi.

⁽⁴⁾ Can be used on internal installations - contact Vokera Technical for advice.

⁽⁵⁾ Outside weather compensation control is supplied in the box with every Linea One.

⁽⁶⁾ Wiring needs to be reconfigured - contact Vokera Technical for advice.

⁽⁷⁾ Compact A 24 hour analogue clock kit includes a pipe cover that the analogue clock is incorporated into.

Financial incentives to help improve energy efficiency

Providing solutions for the future

Almost one third of the UK's carbon emissions come from the energy we use in our homes, with hot water and central heating accounting for over 70% of this.

With fuel costs continuing to rise and natural energy resources depleting we need to be considering alternative, sustainable and more efficient ways of providing energy. While legislation will enforce the integration of renewable technologies into new build projects, the issue of improving the energy efficiency of existing homes is a major concern with 87% of UK homes still likely to be around in 2050. Not only does the UK have to meet carbon emission reduction targets, but we are all having to deal with rising energy costs. The need to help householders and commercial businesses to improve efficiency has resulted in the Government introducing a number of initiatives.

For more information on these, visit www.vokera.co.uk or www.decc.gov.uk for updates

Summary of Initiatives

The Green Deal - Helps homeowners improve the energy efficiency of their homes, without any up front costs. Under the Green Deal, homeowners can get a loan to cover the costs of energy saving products, however this loan is different because the repayments are promised to be the same as or lower than what the homeowner is predicted to save on bills each month from having energy saving products installed; so there's no net cost. For example, if the homeowner's energy bill is £1,000 a year now, their energy bill PLUS green deal repayments (including interest) will never be more than that - sometimes less. So there's no net increase in cost to the homeowner, and they have a more energy efficient home.

The loan is repaid between 10 and 25 years depending on the improvements and is attached to the property's electricity bill (because not everyone has gas), so if the homeowner moves or rents the property out, the new owners/tenants will pay the electricity bill including the green deal repayments. Energy saving products included in The Green Deal include boiler upgrades, heating controls, renewable technologies as well as many other products.

Renewable Heat Incentive (RHI) Commercial Sector - Long-term tariff support available for the big heat users in the non-domestic sector, from large-scale industrial heating to small business and community heating projects. Tariffs are offered on a range of technologies with payments being made for each kWh of renewable heat that is produced, with the level of support dependent on the renewable technology that is installed. Following an early tariff review carried out by the Government in December 2013, new tariffs were announced and are available on any system accredited after 21st January 2014. The increase will be applied only when the tariffs come into affect and they will not be back dated, all eligible commercial installations completed after 15th July 2009 and up to the launch of the RHI, will be eligible for support from the date of the RHI's introduction. Visit www.decc.gov.uk for more information and the latest tariffs.

Domestic Renewable Heat Incentive (RHI) - The scheme is designed to financially reward those who use renewable energy to heat their home. Opened on the 9th April 2014, the domestic RHI is available to anyone who meets the joining requirements. It offers quarterly tariff payments for every kWh of renewable energy that is produced using certain technologies to heat homes and the amount of money that is paid depends on which technology is used. To receive the domestic RHI tariff funding, eligible installations must have been installed after 15th July 2009 and all installations must be carried out by an MCS approved installer using MCS approved products to qualify.

For more information on how you can benefit from any of the above visit www.vokera.co.uk where you will find short guides to help you understand all aspects of these Government incentives.

Renewable Technology

Solar thermal

Solar thermal has become one of the most cost efficient renewable technologies currently available for reducing CO₂ emissions, harnessing the sun's natural energy to heat water.

Solar thermal collectors absorb the sun's energy, which is absorbed by the heat transfer fluid that circulates around the collector and pipework to a twin coil cylinder that heats the domestic hot water. The water is then stored ready for supply to the taps. When the system does not heat to the required temperature the boiler steps in to make up the difference.

By installing Solar thermal you can expect to save on average around 350 - 400kg of CO₂ per year. Financial returns will depend on a number of factors including, among others, location of property, positioning of collectors on the roof, weather conditions and which fossil fuel you are replacing.

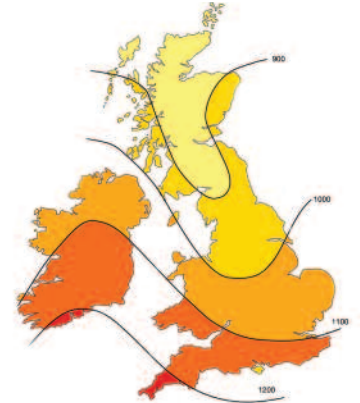

Fig 1 - Source: Solar Trade Association

Fig 1 shows the annual average solar radiation falling on one m² measured in kW hours. (UK and Ireland).

Zenith Solar thermal systems



Our high grade MCS approved Solar collectors maximise energy efficiency and meet the approved standard of BS EN12975 and have the Solar Keymark seal of approval.

Zenith 'Evacuated Tube' collectors - Vokèra Zenith evacuated tubes are made up of 14 double sleeve evacuated glass tubes. The vacuum inside the double sleeved glass tubes provides effective thermal insulation and permits the collectors to generate heat from the sun even in bad weather and during winter months. Zenith evacuated tubes can be more efficient than flat plate collectors in colder, less sunny parts of the UK and are suitable for retro fit and new build applications.

Zenith 'On Tile' collectors and 'Inset' collectors - Vokèra Zenith on tile flat plate collectors and inset flat plate collectors are of high build quality and are designed to use both direct sunlight and daylight to gain the maximum amount of energy throughout the whole year. Zenith on tile collectors are more suited to retro fit applications and inset collectors to new build applications or for those requiring a more discreet finish.

Design and Installation

The Vokèra renewable portfolio can be incorporated to form many different heating system layouts that fulfil all heating and domestic hot water requirements.

The below diagrams show how the Vokèra Zenith range can be teamed with Vokèra boilers to further reduce reliance on fossil fuels and maximise the benefits of renewable energy. For a Solar efficiency and suitability report contact the Vokèra Pre Sales team.



Zenith Solar system
Mynute i sealed system boiler
Aquaflow Twin coil cylinder



Zenith Solar system
Mynute VHE regular open vent boiler
Aquaflow Twin coil cylinder

Zenith Evacuated Tube Solar thermal collectors



SPECIFICATIONS	Evacuated Tube Collector
Total area	2.77 m ²
Exposed area	2.40 m ²
Effective absorption area	2.69 m ²
Dimensions H x W x D (mm)	1730 x 1600 x 145
Empty weight	52 kg
Liquid content	2.05 L
Recommended flow rate of panel (per m ² /hr)	30 L
Absorption (α)	> 94%
Emissions (β)	< 7%
Maximum permitted pressure	10 bar
Maximum temperature	236 °C
Optical efficiency / Zero Loss Collector (η ₀)	0.676
Thermal dispersion factor a ₁ W/(m ² K)	1.15

EVACUATED TUBE COLLECTOR PACKAGE CODES	
Description	Code
Evacuated tube pitched roof package	29450193
Evacuated tube flat roof package	29450194

EVACUATED TUBE COLLECTOR PACKAGE INCLUDES	
Evacuated Tube Solar collectors (x2)	Air Vent
Roof kit (pitched or flat roof)	Expansion vessel
Glycol	Premium controller
Pump station	

MCS approved demonstrating the quality and reliability of the Zenith Solar thermal collector range.

Evacuated tube technology provides better efficiency in cooler parts of the UK due to their ability to absorb and retain Solar radiation, with the tubes working on the same principle as a vacuum flask.

High build quality designed to use both direct sunlight and daylight maximising energy performance even on cloudy days.

Ideal for retro fit and new build applications.

Evacuated tube collectors are easy to install, if necessary, the tubes can be removed prior to the frame being fitted onto the roof. The tubes can then be positioned within the collector frame.

Zenith Solar thermal packages include an intelligent controller for increased functionality and flexibility.

Evacuated tube collectors have greater application flexibility, this is due to the wider range of angles the collector can be positioned in, while maintaining effective absorption.

Easy replacement of glass tubes without having to empty the Solar heating circuit.

As a guide 1m² of Solar collector is required per person in a household. Up to 6 collectors can be connected in a series.

Zenith Solar thermal collector systems are pressurised which provides greater flexibility for siting of the collector and a faster reaction time to daylight and sunlight, maximising upon the sun's energy.

Integrated CPC mirrors maximise absorption even in oblique light.

A highly selective finish on the copper absorber plate within each tube guarantees exceptional absorption performance.

14 individual tubes in each collector.

Long working life, with no metal parts passing through the glass tubes to cause loss of vacuum.

Solar Keymark seal of approval.

Pre Sales service available to provide advice and assistance on suitability and free design service.

PRE SALES SUPPORT FOR SOLAR THERMAL

Vokera Pre Sales support offers practical, sound advice and will advise you if a solution is not fit for purpose, ensuring the correct products are recommended for the application.

Information regarding the Solar installation is input into a TSOL simulation software programme that processes the data and the findings are submitted in a detailed bespoke specification report.

The report documents potential annual results including proposed collector power, natural gas savings, system efficiency and a graphical analysis of Solar thermal performance, see Fig. 2 for an example. With this information the most cost effective and efficient solution can be determined.

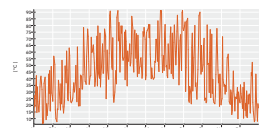

Fig 2. Daily maximum collector temperature graphical analysis

Email: pre-sales@vokera.co.uk

Zenith Flat Plate 'On tile' 'Inset' Solar thermal collectors



ON TILE COLLECTORS - Ideal for retro fit applications with Solar collectors sitting on top of the roof tiles, therefore requiring minimal adaptation to the roof.

INSET COLLECTORS - Ideal for new build applications with collectors sitting in the roof therefore requiring less roof tiles and resulting in a neat and discreet finish.

MCS approved demonstrating the quality and reliability of the Zenith Solar thermal collector range.

High build quality designed to use both direct sunlight and daylight, and a highly selective finish on the copper absorber plate maximises energy performance even on cloudy days.

The collectors have an aluminium body, with a single - piece copper absorber plate to create a greater reflective surface, maximising energy performance.

Flat plate collectors achieve optimum performance when positioned on a south facing roof at an angle of 35° and 45°. If this position is not possible a split system could be used whereby one collector would be placed on the east facing side of the roof and another on the west.

The collectors are ultrasonically welded together to ensure high build quality and product longevity.

Heat transfer fluid flows through 12 individual copper pipes in the collector to create a large surface area for absorption.

As a guide 1m² of Solar collector is required per person in a household. Up to 6 collectors can be connected in a series.

Zenith Solar thermal collector systems are pressurised which provides greater flexibility for siting of the collector and a faster reaction time to daylight and sunlight, maximising upon the sun's energy.

The bottom and walls of the collector tray are lined with 4cm of rock wool insulation to maximise heat retention and energy efficiency.

Low iron oxide content for high energy transmission and to minimise corrosion.

Each collector is protected with tempered glass to withstand extreme weather conditions, such as hail stones.

A well installed Zenith system will provide a reliable and extremely efficient service with a life expectancy of approximately 20+ years.

Pre Sales service available to provide advice and assistance on suitability and free design service..

SPECIFICATIONS	Flat Plate Collector
Total area	2.43 m ²
Exposed area	2.20 m ²
Effective absorption area	2.15 m ²
Dimensions H x W x D (mm)	2046 x 1186 x 90
Empty weight	40 kg
Liquid content	1.6 L
Recommended flow rate per m ² (l/hr)	30 L
Absorption (α)	95%
Emissions (β)	5%
Maximum permitted pressure	10 bar
Maximum temperature	204 °c
Zero loss collector efficiency (η ₀)	0.798
Collector heat loss efficiency a ₁ W/(m ² K)	4.27

FLAT PLATE COLLECTOR PACKAGE CODES	
Description	Code
On tile pitched roof package	29450195
On tile flat roof package	29450196
Inset slate roof package	29450191
Inset tile roof package	29450192

FLAT PLATE COLLECTOR PACKAGE INCLUDES	
Flat Plate Solar collectors (x2)	Air Vent
Roof kit	Expansion vessel
Glycol	Premium controller
Pump station	

CHOOSING THE RIGHT SOLAR EQUIPMENT

If you are considering taking the step into Solar thermal it is important to:

Carry out a TSOL simulation prior to the Solar installation. This ensures the suitability of the Solar equipment and identifies the ideal components, Vokera offers this service.

Check that the product has the Solar Keymark seal of approval as this shows that the equipment fulfils the European Standards and ensures a reliable quality system that is backed by reliable performance information.

Check that the equipment is MCS approved, ensuring it is eligible for the RHI and RHPP grant fundings.

Email: pre-sales@vokera.co.uk

AquaFlow Twin

Unvented twin coil water cylinder



COMPATIBLE WITH
SOLAR THERMAL



2
year
warranty

25 YEAR
GUARANTEE ON
INNER SHELL



Install the Aquaflow Twin with a Zenith Solar thermal system and a system or open vent boiler to benefit from Solar thermal energy.

Inner shell guaranteed for 25 years, made from Super-Molybdenum.

Cylinder manufactured from high grade corrosion resistant stainless steel.

Easy and quick to install.

Internal secondary expansion via self generating air gap means no expansion vessel required, or use fully flooded cylinder with an additional expansion vessel.

Balanced cold water supply point.

Secondary return facility on all units as standard.

No need for 'sacrificial anode' due to excellent anti-corrosion properties of Super-Molybdenum.

No cold water feed tanks required means a dry roof space.

Twin coil units supplied with one two port motorised valve.

Twin coil units are supplied with one low level immersion heater factory fitted and hard wired complete with surface mounted thermostat.

Twin coil cylinders have two thermostats, upper for boiler heating and lower for Solar pre-heater.

Cylinders are supplied with all mandatory valves and fittings.

SPECIFICATIONS	AquaFlow Twin 250	AquaFlow Twin 300
Product order code	924	925
Unvented capacity	207 litres	239 litres
Approximate weight full	255kg	297kg
Flooded capacity	250 litres	300 litres
Approximate weight fully flooded	312kg	364kg
Height	1400mm	1600mm
Diameter	580mm	580mm

1. Hot water outlet
2. Pressure reducing valve
3. Expansion/check valve
4. Flexible connection
5. TPR valve
6. Tundish
7. Discharge pipe
8. Cylinder thermostat
9. Cold feed tube
10. Drain cock
11. Ret 3/4 inch
12. Sensor Boss 1/2 inch
13. Cable entry
14. Flow 3/4 inch
15. Flow 3/4 inch
16. Secondary return 1/2 inch
17. Ret 3/4 inch
18. Sensor Boss 1/2 inch
19. Immersion element

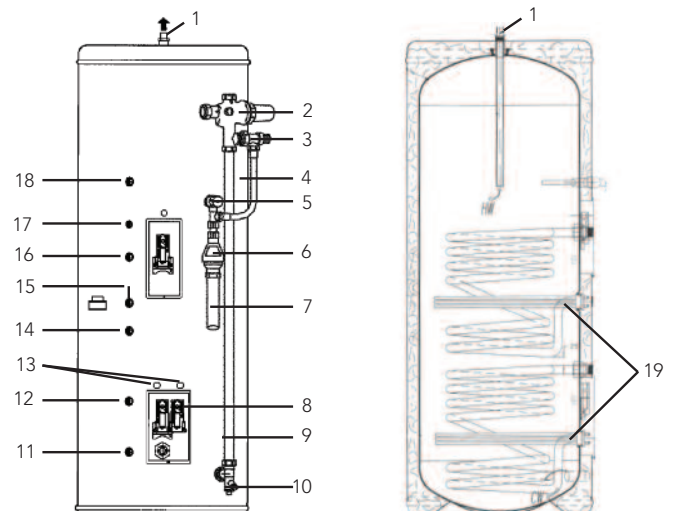

Renewable Technology

Air source heat pumps

Air source heat pumps utilise air to generate heat in order to heat water using compression technology, providing a great source of renewable energy.

Air source heat pumps work by extracting heat from the outside air, even when it's below 0°C. The extracted heat is then transferred to a plate-heat exchanger that heats the central heating and domestic water in a traditional way.

Air source heat pump technology is best suited to low temperature or under-floor heating systems as they require a lower flow temperature but some models are also able to achieve higher temperatures that are suitable for traditional central heating systems and domestic hot water (when connected to a water cylinder). Vokèra recommend that the AriaPRO is installed with an additional back up heat source, for example an immersion heater, to ensure all domestic heating and hot water requirements are satisfied.

AriaPRO air source heat pumps

The Vokèra AriaPRO can reach a CoP (Co-efficient of Performance) of 4.2*, i.e. 1kW of electrical energy can provide 4.2kW of heat output or £1 of electricity can provide over £4 of heat. The appliance can be effective in temperatures ranging from -20°C to +30°C and so will continue to provide heat even in the cold winter months.

Sited outside a property without the requirement for extensive installation preparation the AriaPRO is an ideal renewable solution for both new build and retrofit applications.

*Dependent on ambient outside temperature

Design and Installation: AriaPRO air source heat pump system

The Vokèra renewable portfolio can be incorporated to form many different heating system layouts that fulfil all heating and domestic hot water requirements. The below diagram shows how the Vokèra AriaPRO air source heat pump can be teamed with Vokèra cylinders to further reduce reliance on fossil fuels and maximise the benefits of renewable energy.

AriaPRO air source heat pump
Aquaflow single coil cylinder

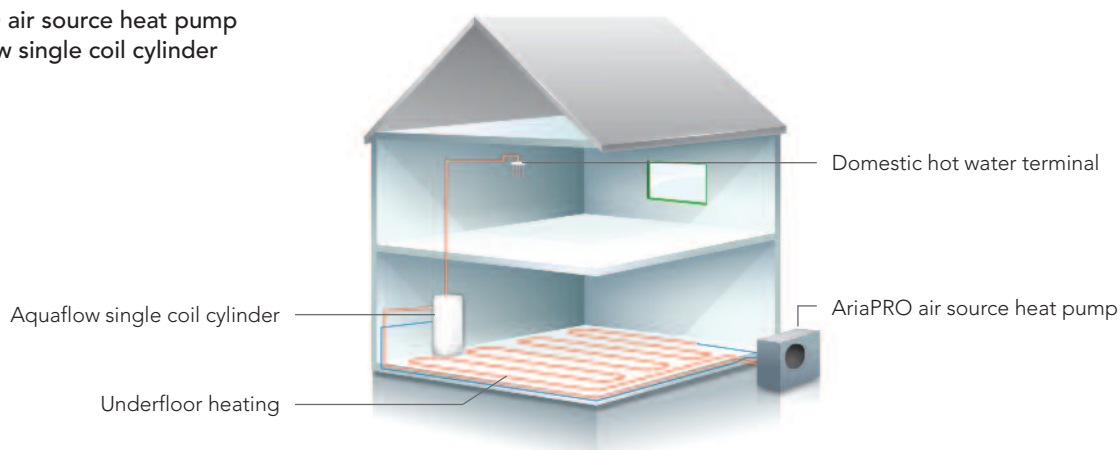

A Vokèra boiler can be teamed with the AriaPRO air source heat pump to make up any differential in heat requirements, ensuring maximum end user comfort.

AriaPRO

Air source heat pump



MCS approved demonstrating the quality and reliability of the AriaPRO range.

Extracts heat from ambient air, even when outside temperature is below 0°C, which is then transferred to a heat exchanger that heats the central heating and domestic hot water in a traditional way.

Co-efficient of Performance (CoP) of up to 4.2 i.e. 1.0kW of electrical energy required to generate 4.2kW of heat output (£1 of electricity can provide over £4 of heat) at EN 14511 reference conditions.

Designed for a simple installation as the integrated hydronic module requires the addition of only a few external components.

Mono-block design means that the refrigerant circuit is located in the outdoor equipment only, enabling the AriaPRO to remain outside the scope of the F-Gas directive for installation; so no F-Gas certification is necessary to install the product.

Latest inverter technology with twin rotary compressor managed by both PAM and PWM logic control ensures both temperature and efficiency is optimised at all times leading to fuel efficiency, lower noise emissions and improved comfort.

Built-in frost protection, protects the appliance from damage during periods of cold weather.

Both central heating and domestic hot water can be provided when connected to a water cylinder.

The Vokèra heat pump system can incorporate Vokèra Zenith Solar thermal to further minimise reliance on fossil fuels.

Compatible with most Vokèra boilers, with the boiler making up any differential in heat requirement, maximising end user comfort.

SPECIFICATIONS	AriaPRO 4kW	AriaPRO 6kW	AriaPRO 8kW	AriaPRO 12kW	AriaPRO 15kW
Product order code	20033107	20033108	20033109	20033110	20033111
Co-efficient of Performance (1)*					
Nominal capacity (kW)	4.1	5.8	7.2	11.9	14.5
Power input (kW)	1.01	1.37	1.84	3.04	3.57
CoP 0/35°C	4.06	4.24	3.95	3.94	4.06
Energy class	A	A	B	B	A
Co-efficient of Performance (2)* Typical UK and Ireland conditions					
Nominal capacity (kW)	3.9	5.8	7.4	12.95	14.5
Power input (kW)	1.21	1.93	2.34	4.3	4.36
CoP 0/45°C	3.2	3.01	3.16	3.01	3.21
Energy class	A	B	B	B	B
Dimensions and weights					
Height (mm)	821	821	821	1363	1363
Width (mm)	908	908	908	908	908
Depth (mm)	350	350	350	350	350
Empty weight (kg)	61	61	71	105	105
Sound levels					
Sound pressure** (db)	42	42	44	47	48
Electrical					
Voltage (V/Hz)	230/50	230/50	230/50	230/50	230/50

* CoP (1) - outside air +7°C / water 30-35°C.

* CoP (2) - outside air +7°C / water 40-45°C.

** Sound pressure measured in a hemispheric field 4 meters in front of the fan.

Sited outside a property without the requirement for extensive installation preparation.

Flexible application, suitable for both new build and retrofit applications.

Effective in outside air temperatures ranging from -20°C to +30°C.

Flow outlet temperature ranging up to +60°C, making the AriaPRO ideal for a number of domestic applications including underfloor heating, central heating and domestic hot water.

Electronically controlled variable speed helical fan ensures exceptionally low noise levels as low as 42 dBa (4 and 6kW outputs).

Supplied with built-in external sensor, a supplementary external sensor and remote control, to maximise efficiency.

Integral 2 litre expansion vessel supplied with the 4kW, 6kW, 8kW and 3 litre expansion vessel supplied with the 12kW and 15kW. Additional expansion capacity may be necessary dependant on the system.

Vokèra Support

Technical training

Vokèra offer training nationwide, we have 4 Vokèra training centres and 7 satellite centres:

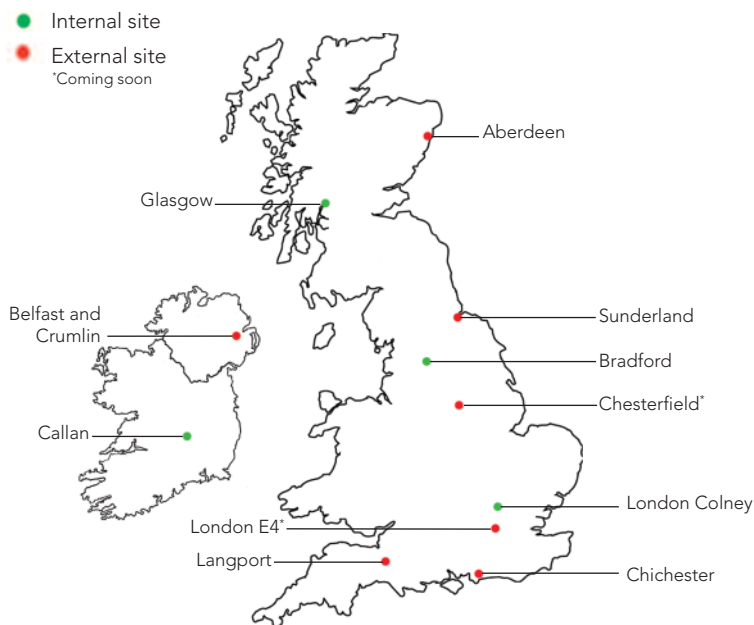

Vokèra technical training delivers real value to Gas Safe Registered engineers. Our technical training focuses on an engineers need to become familiar with the product and to enable quick and simple installation or repair.

Our technical training is structured to ensure you cover: the appliance range, installation, operation, wiring, flueing, benchmark, fault finding and commissioning. To attend you must be Gas Safe Registered.

Vokèra Product Courses

High Efficiency Product Course explains how condensing boilers operate through using controls such as zero governors.

Fault Finding Product Course is designed for engineers to test their knowledge & fault finding skills in a real life environment on working boilers.

Controls course can help you understand the fundamentals of how control technology can work in conjunction with boiler operation.

Renewables Overview Product Course will provide you with an understanding of the Vokèra Zenith Solar products, Air Source Heat pumps and an insight into the theory of Solar Domestic Hot Water.

Individual or tailored Workshops are tailored to the individual/groups training requirements.

CondexaPRO Product Course contains an overview of the features and components of the boiler, system configurations, wiring of the external controls, flue options and commissioning.



Certificated Courses

All certificated courses are accredited by LOGIC Certification. Our range of certificated 1 day courses include:

Energy Efficiency Certificate looks at energy efficiency for boilers, hot water and controls with an open book exam at the end and is based on a pre-defined PowerPoint presentation.

Hot Water Systems and Safety Certificate is recognised by those Competent Person Schemes (CPS) and covers: water regulations, unvented requirements, Legionella overview and much more.



Vokèra also offer a variety of CPD presentations, please contact Vokèra training for more information.



CUSTOMER FEEDBACK

Vokèra product courses receive many positive comments from those who have attended them, below is a selection of comments received recently:

- One of the best courses I have attended.
- Clear and precise explanations given during the course.
- The trainer provided such good valuable knowledge about the new boiler, it makes me feel comfortable and happy to install Vokèra.
- The trainer opened my mind up about the boilers, made everything so easy to understand and the course was practical and hands on. I cannot compare this training with any others I have had in the past.
- I found the course very useful and hands on and it really helped boost my confidence on the new boiler ranges.

CONTACT VOKERA TRAINING

Telephone:	0844 391 0999 (option 5)
Email:	training@vokera.co.uk



Vokèra Support

Customer Care Team - 0844 391 0999 (option 2)

We pride ourselves on providing a first class after sales service with a dedicated customer care centre in the UK and Ireland, supported with 41 factory trained Vokèra field engineers along with 85 service agents, who support every Vokèra installation.

- Every engineer carries a full complement of spare parts to help ensure a high first time fix rate
- Real time data field reports for service contracts
- Full monthly reports can be provided to monitor call outs
- One point of contact to report and discuss service issues
- Full audit trail to track service calls

Technical Support 0844 391 0999 (option 4)

Our fully trained, Gas Safe registered technical team provides post sales technical help to support the Installer.

Product Warranty

As with all domestic gas boilers, an annual service is recommended to maintain optimum performance, efficiency and safety. In addition to a free 2 year, 5 year or 7 year warranty (depending on the boiler model), we also make a promise to all our customers:-

Our dedicated customer service team and Gas Safe registered engineers are available 6 days a week to support the needs of every single Vokèra boiler installation. They aim to respond to every call within 48 hours or less, or at a time agreed with the householder. They will make every effort to solve any technical problem over the phone, answering quickly, politely and at all times acting in the best interest of our customers.

All warranties are subject to registration and annual servicing.

Accreditations and Quality Assurances

Vokèra is recognised for the quality and reliability of its products. At every stage from research and development, through to production and after sales support, we build quality in. Safety is our number one priority.

- BS EN ISO9001:2000 Approved
- Support the 'benchmark' initiative
- Members of the Heating and Hotwater Council
- Members of Energy Utilities Alliance
- Supplier members of the Association of Plumbing and Heating Contractors (APHC)
- Registered Gas Safe with our technical support team and trainers all being Gas Safe registered
- Every product is pre-tested at the factory ensuring the highest quality and reliability



Vokèra is a licensed member of the Benchmark scheme which aims to improve the standards of installation and commissioning of domestic hot water systems in the UK.



CONTACT US	
Department	Email
UK Sales	sales@vokera.co.uk
Spares Team	spares@vokera.co.uk
Customer Care Team	service@vokera.co.uk
Pre Sales	pre-sales@vokera.co.uk
Marketing Support	marketing@vokera.co.uk

CONTACT US	
Department	Email
UK General Enquiries	enquiries@vokera.co.uk
Technical Support	technical@vokera.co.uk
Customer Relations	custrelations@vokera.co.uk
Technical Training	training@vokera.co.uk
Boiler Upgrade	boilerupgrade@vokera.co.uk



Registered address:

Vokera Ltd
Borderlake House
Unit 7 Riverside Industrial Estate
London Colney
Herts AL2 1HG

enquiries@vokera.co.uk

www.vokera.co.uk
www.vokera.ie

Sales, General Enquiries:

T 0844 391 0999
F 0844 391 0998

Vokera Ireland
West Court, Callan
Co Kilkenny
T 056 7755055
F 056 7755060

Vokera Limited reserve the right to change
specification without prior notice.
Consumers statutory rights are not affected.
E&OE

Company Reg No: 1047779

Search Vokera Ltd

