

BRISTAN

Round Pop Up Slotted Basin Waste

Installation Instructions & User Guide



IMPORTANT: Please keep these instructions for future reference and request of replacement parts

Introduction

Thank you for choosing Bristan, the UK's leading taps and showers expert. We have designed this product with your enjoyment in mind. To ensure that it works to its full potential, it needs to be fitted correctly. These fitting instructions have been created to give you all of the information you need and, if you need any further help, please do not hesitate to give us a call on 0844 701 6273.

Installation

1. Identify all components are present prior to installation.
2. Fit the pop-up waste. Bed in the waste flange (1) to the basin with a good quality clear silicon sealant. This should compensate for any slight moulding imperfections that may be present around the waste area.
3. Fir the large rubber seal (2) to the underside of the basin after applying silicone sealant to both sealing surfaces, as shown in the diagram below. Secure by tightening the waste body (3) onto the flange's thread. Remove any excess silicon sealant from the basin
4. Place the pop-up knob & shroud assembly (10) onto the basin & secure using the small foam washer (9), metal plate (8) & retaining nut (7) on the underside of the basin.
5. Use pop-up link (5) to connect the vertical (6) & horizontal (4) connecting rods.
6. Check all joints & connections for any leaks.

COMPONENTS

1. Waste Flange
2. Large Rubber Seal
3. Waste Body
4. Horizontal Connecting Rod
5. Retaining Nut
6. Metal Plate
7. Small Foam Washer
8. Pop-up Knob & Shroud
9. Plug (Not Shown)

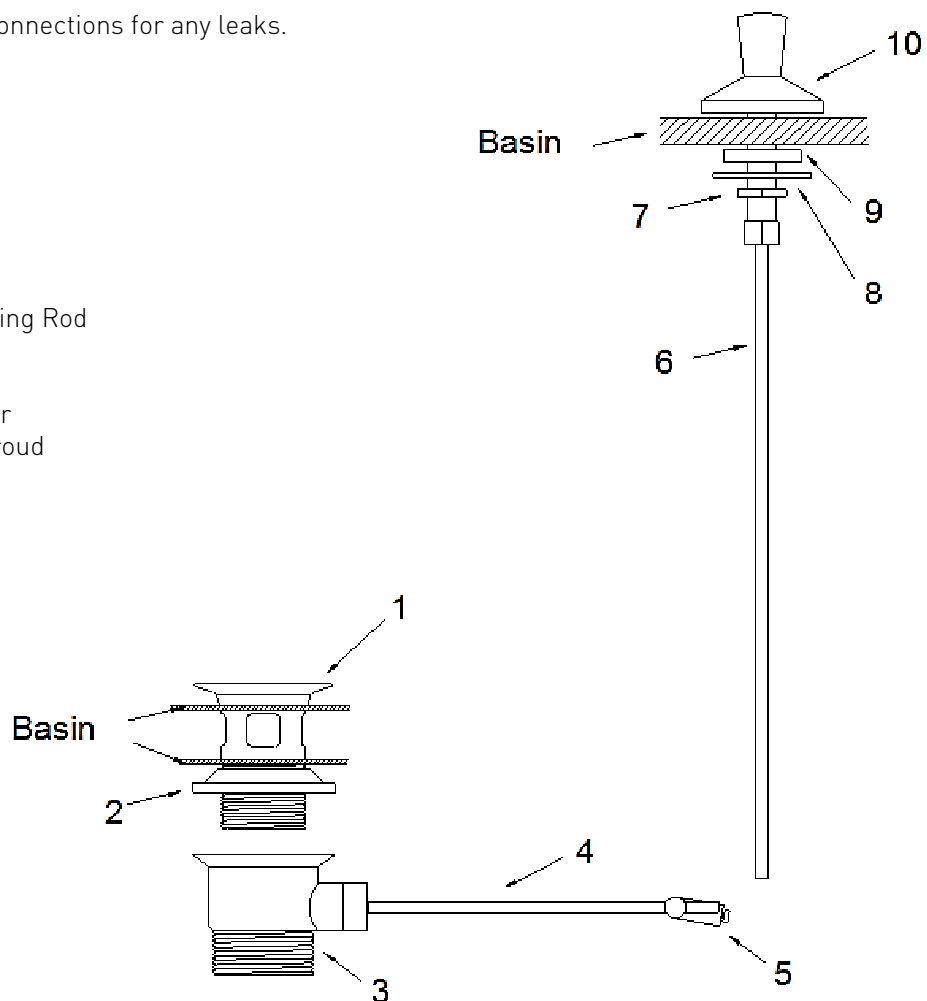



Guarantee

Bristan Guarantee

2 year -

Pumps, Power Showers

2 year parts. 1 year labour (subject to registration).

Electric Showers/Instantaneous Water Heaters

2 year parts. 1 year labour (subject to registration).

5 year -

Taps and Mixers

5 year parts and 1 year labour (subject to proof of purchase).

Shower Valves

5 year parts. 5 year labour (subject to registration), else 1 year with proof of purchase.

Accessories

5 year parts only. Includes bathrooms accessories, shower accessories (e.g. hoses, handsets and poles), wastes, WC levers and light pulls.

10 year -

Shower enclosures, Shower Trays, Sanitary Ware & Furniture

10 year parts (subject to registration), else 2 years with proof of purchase. 1 year labour (subject to registration), else 1 year with proof of purchase.

This guarantee applies to products purchased within the United Kingdom or Republic of Ireland, but does not apply to products used commercially.

The guarantee is only available to original purchasers who have proof of purchase.

The installation must allow ready access to all products for the purpose of inspection, maintenance or replacement.

Any part found to be defective during the above guarantee period will be replaced without charge, providing that the product has been installed in accordance with the instructions, used as intended, and regularly serviced.

Servicing should be carried out at regular intervals of no more than 12 months and more frequently in hard water areas (heavy lime scale) areas.

In the unlikely event that any problems are encountered with the product's performance on installation, you must obtain guidance/authorisation from our Customer Service Department, and be able to supply proof and date of purchase, before any remedial action is taken.

The guarantee excludes general wear and tear and damage caused by accident, misuse or neglect, and does not cover the following:

Components that are subject to general wear and tear such as filters, seals, 'O' rings and washers etc.

- Damage caused by faulty installation
- Damage caused by lime scale or any waterborne debris
- Damage caused by inappropriate cleaning products (see user instructions)
- Damage caused by the use of non-Bristan parts
- The product being used for a purpose other than intended by the manufacturer.

In the interests of continuous product improvement Bristan reserves the right to alter specification as necessary.



Guarantee



Guarantee



Guarantee



Guarantee

BRISTAN

This booklet covers all product codes

W BASIN13 C

Helpline

0844 701 6273

Bristan Group Limited

Birch Coppice Business Park, Dordon, Tamworth, Staffordshire B78 1SG

A Masco Company

Website: www.bristan.com

Telephone: 0844 7016 274 Facsimile: 0844 701 6275

Email: enquire@bristan.com