

## OPAC

### Thermostatic Concealed Shower Valve Only with Lever Handle

#### Product Specification

Product Code:	OP TS1503 CL C
Finish:	Chrome
Product Type:	Commercial
Construction:	Body is of brass construction and is designed to conform to BS EN 1111:1999 (HP) & BS EN 1287:1999 (LP)
Valve Type:	Thermostatic Cartridge
Supply:	Suitable for all plumbing systems (Preferably balanced)
Inlet Connections:	15mm compression elbows
Outlet Connections:	½" BSP
Working Pressures:	Min 0.2bar, Max 8.0bar
Cavity Depth:	<b>Min 64mm, Max 74mm</b>
Dimensions for Fitting:	175mm inlet centres



#### Additional Information

- Single sequential control for both temperature & flow.
- Anti-vandal stainless steel concealing plate
- Automatic thermostatic shut-off in the event of hot or cold water failure.
- Check valves and serviceable filters as standard
- Supplied as 'valve only' and thus can be customised by choosing accessories from our Pick 'N' Mix showering options. Please see our Product and Price guide for details.
- Chrome plated to BS EN 248.

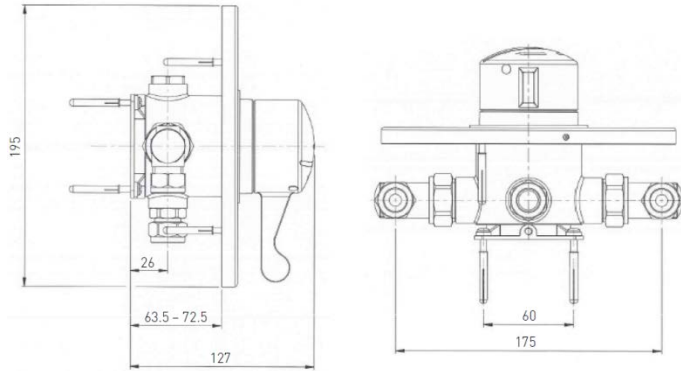

#### Flow Rates (litres per minute)

System Pressure	0.2bar	0.5bar	1bar	2bar	3bar	4bar	5bar
Flow Limiters Fitted	4.6	6.8	7.1	8.1	8.6	8.9	9.0

#### Compliance / Approvals

WRAS:	Certificate N <sup>o</sup> : 1311021
TMV3:	Certificate N <sup>o</sup> : BC397/1208

**Technical Advice:** For further information please call 0844 7016273 or email [customercare@bristan.com](mailto:customercare@bristan.com)

**Guarantee:** 1 year covering manufacturing faults.

Bristan, Birch Coppice Business Park, Dordon, Tamworth, B78 1SG  
 Telephone: 0844 701 6274 Facsimile: 0844 701 6275  
 Web Site: [www.bristan.com](http://www.bristan.com) Email: [enquire@bristan.com](mailto:enquire@bristan.com)

