

## NON - CONCUSSIVE TAPFITTING INSTRUCTIONS

Congratulations on purchasing this Non - Concussive tap. This quality product is manufactured to exacting standards and will provide many years of reliable service if the following instructions are adhered to.

- 1) Turn off electric immersion and gas water heaters.
- 2) Turn off the hot and cold water supplies, drain taps.
- 3) Carefully remove old taps.
- 4) Connect the mains pipes to the taps (Note G1/2" thread connection).
- 5) Operate the tap several times to flush out the system after turning the water back on.
- 6) Your Non - Concussive tap is now fitted and ready to use. The time delay is not adjustable.

### IMPORTANT NOTE

The good working pressure of Non - Concussive taps is from 0.1 to 3 Bar. In areas with high water pressure the action of the tap may be effected, to overcome this problem you have to reduce pressure with a flow restrictor or with pressure reducers. Please note that the time delay action of the tap may fluctuate with water pressure as water pressure may vary from time to time.

### AFTERCARE INSTRUCTION

These taps have a high quality finish and should be treated with care to preserve the visible surface. All surface finishes will wear if cleaned incorrectly, the only safe way to clean your tap is to wipe with a soft damp cloth. Stains can be removed using washing up liquid. All bath cleaning powders and liquids will damage the surface of your taps even the non - scratch cream cleaners.

### GUARANTEE

All products are extensively tested before despatch and a 1 year guarantee covers any defect in manufacture. The good operation of a Non - Concussive tap is guaranteed only with a clean water system. It is advisable to use a filter in the water system to prevent debris entering the tap.

## BRISTAN

Bristan Group Ltd  
Birch Coppice Business Park  
Dordon  
Tamworth  
Staffordshire  
B78 1SG  
T: 0844 7016274  
E: [customercare@bristan.com](mailto:customercare@bristan.com)

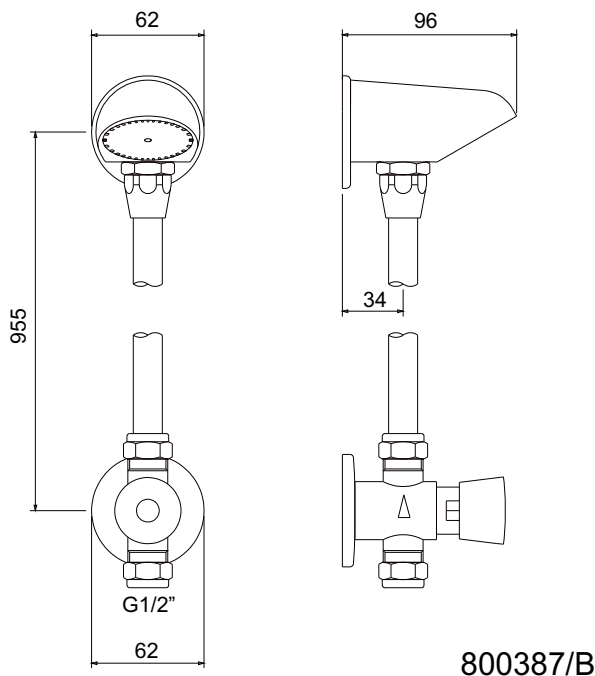

**Customer Care**  
☎ 0844 7016273

## NON - CONCUSSIVE TAPFITTING INSTRUCTIONS

Congratulations on purchasing this Non - Concussive tap. This quality product is manufactured to exacting standards and will provide many years of reliable service if the following instructions are adhered to.

- 1) Turn off electric immersion and gas water heaters.
- 2) Turn off the hot and cold water supplies, drain taps.
- 3) Carefully remove old taps.
- 4) Connect the mains pipes to the taps (Note G1/2" thread connection).
- 5) Operate the tap several times to flush out the system after turning the water back on.
- 6) Your Non - Concussive tap is now fitted and ready to use. The time delay is not adjustable.

### IMPORTANT NOTE

The good working pressure of Non - Concussive taps is from 0.1 to 3 Bar. In areas with high water pressure the action of the tap may be effected, to overcome this problem you have to reduce pressure with a flow restrictor or with pressure reducers. Please note that the time delay action of the tap may fluctuate with water pressure as water pressure may vary from time to time.

### AFTERCARE INSTRUCTION

These taps have a high quality finish and should be treated with care to preserve the visible surface. All surface finishes will wear if cleaned incorrectly, the only safe way to clean your tap is to wipe with a soft damp cloth. Stains can be removed using washing up liquid. All bath cleaning powders and liquids will damage the surface of your taps even the non - scratch cream cleaners.

### GUARANTEE

All products are extensively tested before despatch and a 1 year guarantee covers any defect in manufacture. The good operation of a Non - Concussive tap is guaranteed only with a clean water system. It is advisable to use a filter in the water system to prevent debris entering the tap.

## BRISTAN

Bristan Group Ltd  
Birch Coppice Business Park  
Dordon  
Tamworth  
Staffordshire  
B78 1SG  
T: 0844 7016274  
E: [customercare@bristan.com](mailto:customercare@bristan.com)

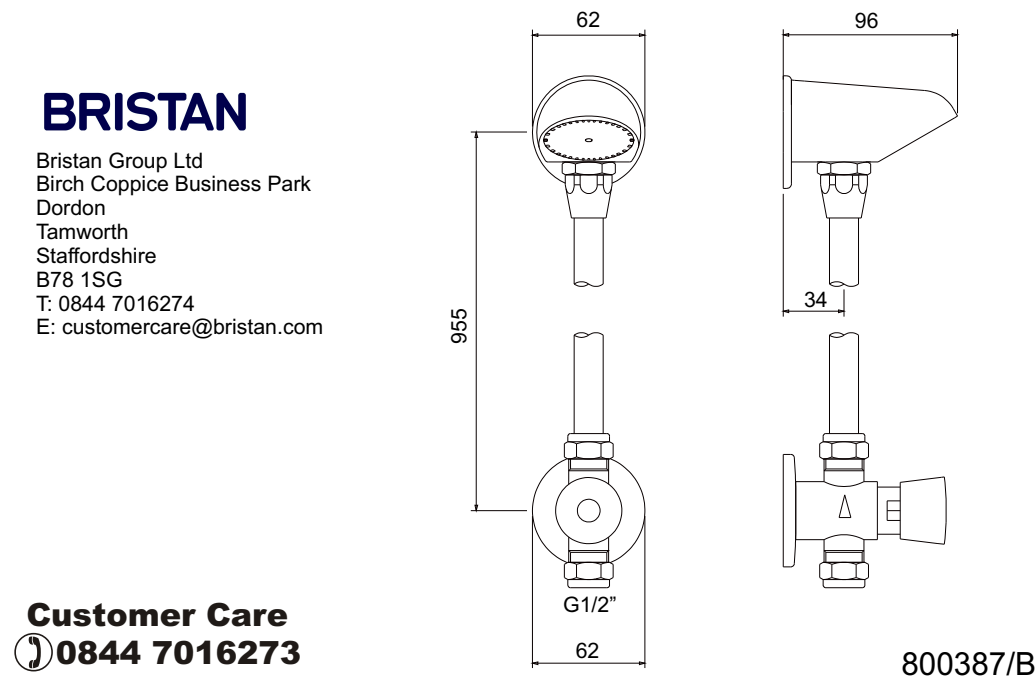

**Customer Care**  
☎ 0844 7016273