

# INSTALLATION AND OPERATING INSTRUCTIONS

SOLAR CONTROLLER

## TDS 100

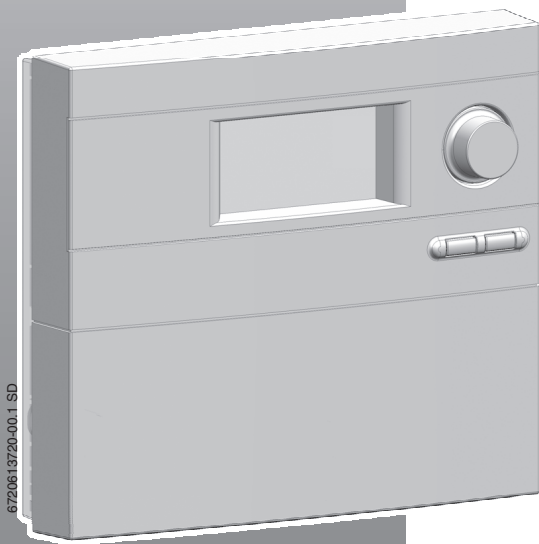

6720613720-00.1 SD



6 720 644 596 (2010/04)

  
**WORCESTER**  
Bosch Group

# CONTENTS

---

<b>Contents</b>	<b>2</b>
<b>1 Safety instructions and explanation of symbols</b>	<b>4</b>
1.1 General safety instructions	4
1.2 Symbols	5
<b>2 Information about the product</b>	<b>6</b>
2.1 EU Declaration of Conformity	6
2.2 Included in delivery	6
2.3 Product description	7
2.4 Specifications	9
<b>3 Regulations</b>	<b>10</b>
<b>4 Installation (For qualified technicians only)</b>	<b>11</b>
4.1 Mounting the controller on a wall	11
4.2 Electrical connection	12
4.2.1 Preparing cable entry	12
4.2.2 Connecting the cables	13
<b>5 Operation</b>	<b>14</b>
5.1 Elements of the solar pump station	15
5.2 Elements of the controller	16
5.3 Operating modes	17
5.4 Displaying temperature values	17
5.5 Main menu (For qualified technicians only)	18
5.6 Expert menu (For qualified technicians only)	21
<b>6 Commissioning (For qualified technicians only)</b>	<b>22</b>
<b>7 Fault Finding</b>	<b>23</b>
7.1 Faults with display indications	23
7.2 Faults without display indications	24

---

<b>8</b>	<b>Notes for the user</b>	<b>26</b>
8.1	Why is regular maintenance important?	26
8.2	Important notes on heat transfer fluids	26
8.3	Checking the solar heating system	26
8.4	Checking operating pressure, with possible re-adjustment	27
8.5	Cleaning the collectors	27

---

<b>9</b>	<b>System Details</b>	<b>28</b>
----------	-----------------------	-----------

# **1 SAFETY INSTRUCTIONS AND EXPLANATION OF SYMBOLS**

## **1.1 GENERAL SAFETY INSTRUCTIONS**

### **ABOUT THIS MANUAL**

This manual contains important information for the safe and correct installation and operation of the solar controller.

This manual is intended for both general users and qualified technicians. Chapters and sections intended only for qualified technicians are marked with the words “For qualified technicians only”.

- ▶ Read this manual carefully and keep it for future reference.
- ▶ Always observe the safety instructions to prevent injury and property damage.

### **CORRECT USE**

The differential temperature controller (called the “controller” in the following) may only be used for the operation of solar thermal systems under the ambient conditions specified (→ section 2.4).

The controller must not be used outdoors, in damp rooms or in rooms where easily flammable gas mixtures could form.

- ▶ Only operate the solar heating system as intended and when it is in perfect working order.

### **ELECTRICAL CONNECTIONS**

Any tasks that require the controller to be opened must be carried out only by qualified electricians.

- ▶ The electrical supply must be connected by a qualified electrician.
- ▶ Make sure that a fuse spur compliant with EN 60335-1 is fitted for all-pole disconnection from the power supply.
- ▶ Isolate all poles of the controller's power supply before opening.

### **DOMESTIC HOT WATER TEMPERATURE**

- ▶ To limit hot water temperature to a maximum of 60 °C a thermostatic mixing valve must be installed.

### **STANDARDS AND GUIDELINES**

- ▶ Observe all standards and guidelines applicable to the installation and operation of the device in your country.

### **DISPOSAL**

- ▶ Dispose of packaging in an environmentally responsible manner.
- ▶ When replacing components, dispose of the old part in an environmentally responsible manner.

## **1.2 SYMBOLS**



**Safety instructions** in this document are identified by a warning-triangle symbol and are printed on a grey background.

Signal words indicate the seriousness of the hazard in terms of the consequences of not following the safety instructions.

- **Caution** indicates that minor damage to property could result.
- **Warning** indicates that minor personal injury or serious damage to property could result.
- **Danger** indicates that serious personal injury could result. In particularly serious cases, lives could be at risk



**Notes** are identified by the symbol shown on the left. They are bordered by horizontal lines above and below the text.

Notes contain important information in cases where there is no risk of personal injury or damage to property.

## 2 INFORMATION ABOUT THE PRODUCT

### 2.1 EU DECLARATION OF CONFORMITY

The design and operation of this product conform to the applicable European directives and supplementary national requirements.

The conformity has been confirmed.

### 2.2 INCLUDED IN DELIVERY

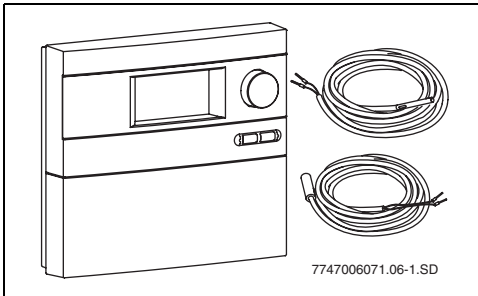

*Fig. 1 Controller TDS 100 with temperature sensors*

- Controller TDS 100
- Collector temperature sensor NTC 20K
- Cylinder temperature sensor NTC 10K
- Mounting materials and strain relief clamps (for wall mounting)

If the controller has been built into a solar pump station, the cables will have been partly pre-fitted.

## 2.3 PRODUCT DESCRIPTION

The controller is designed for the operation of a solar heating system. It can be mounted on a wall or can be built into a solar pump station.

In normal operating mode, the display screen on the controller stays illuminated in green/yellow for five minutes after the last button was pressed (this can be activated by e. g. pressing the rotary selector ).

The display shows the following:

- Pump status (as a simple system diagram)
- System values (e.g. temperatures)
- Selected functions
- Fault indicators

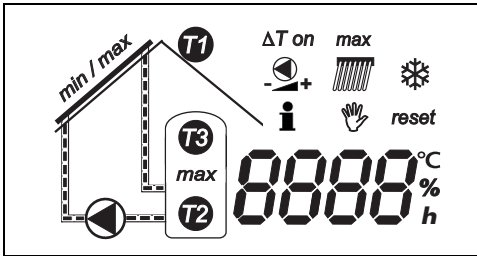

Fig. 2 Possible indications on the display

**DIAGRAM OF SOLAR PUMP SYSTEM**

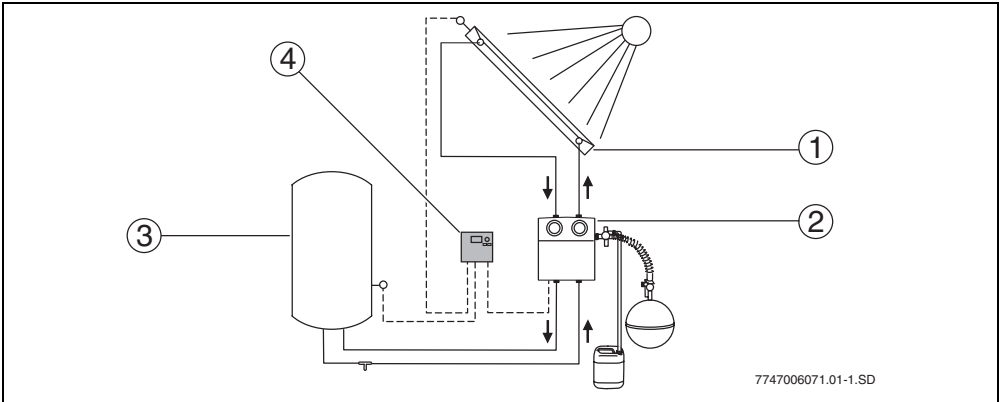

Fig. 3 System diagram

- 1 Collector array
- 2 Solar pump station
- 3 Solar cylinder
- 4 Controller TDS 100

Main components of the solar heating system	
<b>Collector array</b>	<ul style="list-style-type: none"> <li>• Consists of flat plate collectors or evacuated tube collectors</li> </ul>
<b>Solar pump station</b>	<ul style="list-style-type: none"> <li>• Consists of the pump together with safety valves and shut-off valves for the solar pump circuit</li> </ul>
<b>Solar cylinder</b>	<ul style="list-style-type: none"> <li>• Used for storing the collected solar energy</li> <li>• There are three different types:                             <ul style="list-style-type: none"> <li>– Pre-heat cylinder</li> <li>– Thermal Store (to back up a domestic heating system)</li> <li>– Twin coil cylinder (for domestic heating back-up and for potable water)</li> </ul> </li> </ul>
<b>Controller TDS 100</b>	<ul style="list-style-type: none"> <li>• Includes two temperature sensors</li> </ul>

Tab. 1

**OPERATING PRINCIPLE**

When the set temperature difference between the collector array (→ Fig. 3, no. 1) and the solar cylinder (→ Fig. 3, no. 3) is exceeded, the pump in the solar pump station is switched on.

The pump transports the heat transfer medium via the circuit through the collector array to the consumer. This consumer is generally a solar cylinder. There is a heat exchanger in the solar cylinder. This transfers the heat collected from the sun from the transfer medium to the water intended for domestic use or heating.



## 2.4 SPECIFICATIONS

Controller TDS 100	
Power consumption	1 W
Protection	IP20 / DIN 40050
Supply voltage	230 V AC, 50 Hz
Operating current	$I_{Max}$ : 1.1 A
Max. current consumption at pump output	1.1 A (connect one pump only!)
Measuring range	- 30 °C to + 180 °C
Permissible ambient temperature	0 to + 50 °C
Collector temperature sensor	NTC 20K with 2.5m-long cable
Cylinder temperature sensor	NTC 10K with 3m-long cable
Dimensions H x W x D	170 x 190 x 53 mm

Tab. 2 Specifications

Temperature sensor T1 NTC 20K (collector)				Temperature sensor T2/T3 NTC 10K (cylinder)			
T (°C)	R (k Ω)	T (°C)	R (k Ω)	T (°C)	R (k Ω)	T (°C)	R (k Ω)
-20	198.4	60	4.943			60	3.243
-10	112.4	70	3.478			70	2.332
0	66.05	80	2.492	0	35.975	80	1.704
10	40.03	90	1.816	10	22.763	90	1.262
20	25.03	100	1.344	20	14.772	100	0.95
30	16.09	110	1.009	30	9.786	110	
40	10.61	120	0.767	40	6.653	120	
50	7.116	130	0.591	50	4.608	130	

Tab. 3 Resistances of the temperature sensors



The temperature sensors must be disconnected from the controller in order to measure their resistances.

### 3 REGULATIONS

Observe all standards and guidelines applicable to the installation and operation of the system in your country and region.

TECHNICAL REGULATIONS APPLICABLE IN THE U.K. FOR THE INSTALLATION OF THERMAL SOLAR HEATING SYSTEMS

- ▶ Electrical connection:
  - Current IEE wiring regulations
- ▶ Connection of thermal solar systems:
  - EN 12976: Thermal solar systems and components (factory made systems)
  - ENV 12977: Thermal solar systems and components (custom built systems)
  - BS5918: Latest version: Solar heating systems for domestic hot water.
- ▶ Installation and fittings of hot water heaters:
  - BS5546:2006 Specification for installation of hot water supplies for domestic purposes, using gasfired appliances of rated input not exceeding 70kW.
  - BS6700:2006 Specifications for design, installation testing and maintenance of services supplying water for domestic use within buildings and their curtilages.

## 4 INSTALLATION (FOR QUALIFIED TECHNICIANS ONLY)

### 4.1 MOUNTING THE CONTROLLER ON A WALL

The controller is attached to the wall by three screws.



**CAUTION:** Risk of injury and damage to the housing from incorrect mounting.

- ▶ Do not use the rear panel of the housing as a drilling jig.

- ▶ Drill the upper mounting hole (→ Fig 4., no. 1) and screw in the accompanying screw until 5 mm clear of the surface. Unscrew the screw at the bottom of the controller and remove the cover. Hang the controller on the wall by means of the opening in the rear panel. Mark out the lower mounting holes (→ Fig. 4, no. 2), remove the controller, drill the holes and insert wall plugs. Remount the controller and insert the mounting screws through the lower mounting holes, left and right. Ensure the controller is level and screw firmly in place.

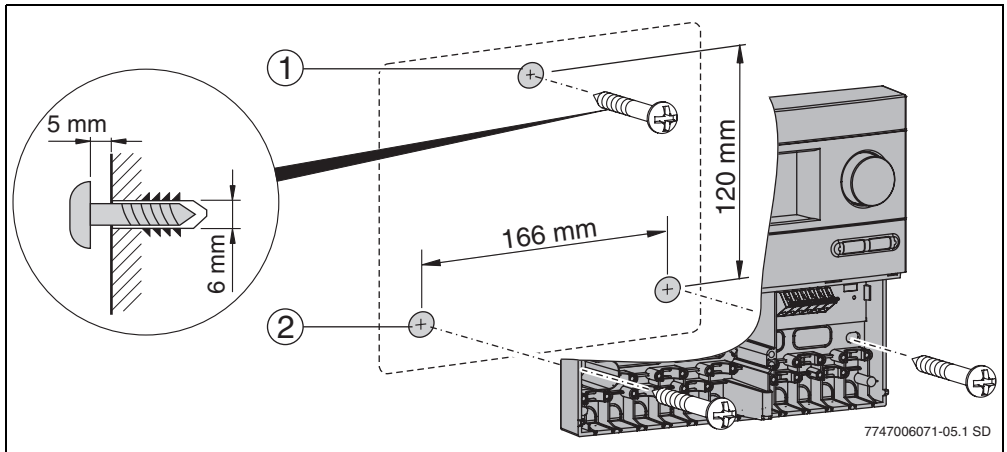

Fig. 4 Mounting the controller on a wall

- 1 Upper mounting hole
- 2 Lower mounting holes

## 4.2 ELECTRICAL CONNECTION



**DANGER:** Risk of death from electric shock.

- ▶ Before opening the device, isolate the power supply (230 V AC)
- ▶ Secure cables with strain relief clamps.

### 4.2.1 PREPARING CABLE ENTRY

Depending on the mounting situation, the cables can enter the housing from behind (→ Fig. 5, no. 4) or from below (→ Fig. 5, no. 3).

- ▶ Maintain IP 20 protection when installing:
  - Cut open only required cable entries.
  - Cut open the cable entry only as much as required.
- ▶ Use a knife to cut open the cable entry (→ Fig. 5) without leaving any sharp edges.
- ▶ Secure the cable using the corresponding strain relief clamp (→ Fig. 5, no. 2). The strain relief clamp can also be fitted in the reverse position (→ Fig. 5, no. 1).

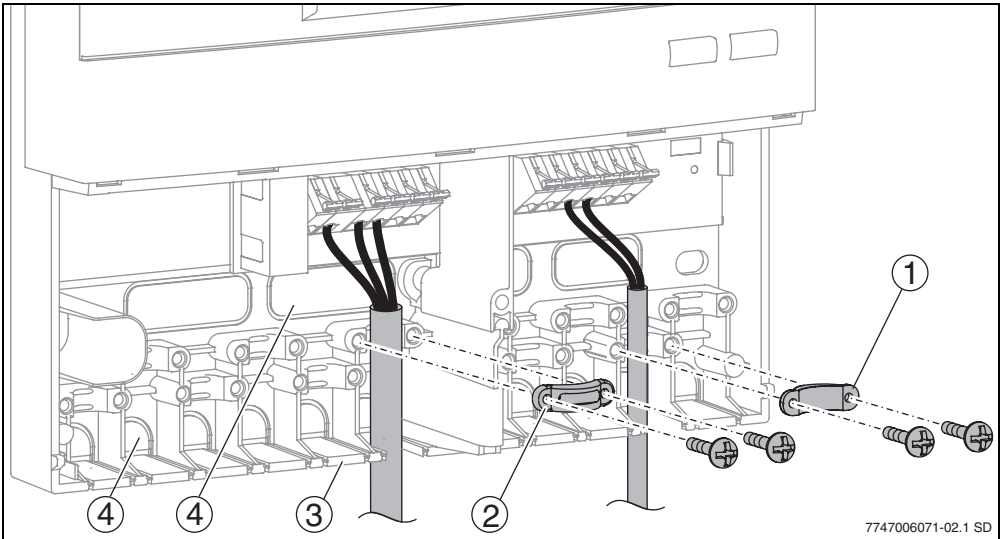

Fig. 5 Entering and securing cables

- 1 Strain relief clamp reversed
- 2 Strain relief clamp
- 3 Cable entry from below
- 4 Cable entry from the rear

**4.2.2 CONNECTING THE CABLES**

Observe the following when connecting the cables:

- Comply with local regulations, such as protective earthing tests etc..
- Use only accessories supplied by the manufacturer.
- Protect the controller from overloads and short-circuits.
- The power supply must correspond to the values on the data plate.
- Connect only one lead to each terminal (max. 1.5 mm<sup>2</sup>).
- Polarity is irrelevant for the temperature sensor leads. The sensor cables can be extended up to 100 m (up to 50 m length = 0.75 mm<sup>2</sup>, up to 100 m = 1.5 mm<sup>2</sup>).
- Lay all sensor cables away from cables carrying 230 V or 400 V, to avoid inductive interference (at least 100 mm).
- Use shielded low-voltage cables, if external inductive interference is expected (e.g. from power substations, high-voltage power cables, microwaves).
- For the 230 V connection, use a cable of at least type H05 VV-... (NYM...).
- Ensure that fire safety structural features are not impaired.



We recommend installing electrical connections with on/off switching capability.

- ▶ Do not connect via the emergency stop switch for the heating system.

- ▶ Connect the cables in accordance with the terminal diagram (→ Fig. 6).
- ▶ Use a screwdriver to open and close the quick-connect terminals.
- ▶ After completing work, close the controller with the cover and the screw.

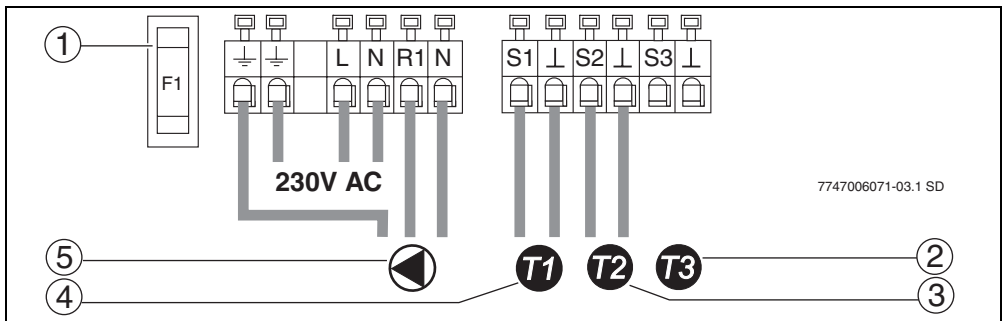

Fig. 6 Terminal diagram

- 1** Fuse 1.6A slow blow
- 2** Temperature sensor T3 for displaying temperature in cylinder middle/top (accessory)
- 3** Temperature sensor T2 for displaying temperature and control value for cylinder bottom
- 4** Temperature sensor T1 for displaying temperature and control value for collector
- 5** Pump (max. 1.1 A)

## **5 OPERATION**

### **NOTES FOR THE USER**

Your professional heating technician will set the solar heating system when commissioning it, and it will run automatically.

- ▶ Do not switch off the solar heating system during long absences (e.g. when going on holiday).  
When installed according to the manufacturer's specifications, the solar heating system is intrinsically safe.
- ▶ Do not modify the controller settings.
- ▶ After a power failure or a long absence, check the operating pressure on the pressure gauge of the solar heating system (→ section 8.4, page 27).

### **NOTES FOR QUALIFIED TECHNICIANS**

- ▶ Give all documents to the user.
- ▶ Explain to the user how the device works and how to operate it.

## 5.1 ELEMENTS OF THE SOLAR PUMP STATION

The main components of the solar pump station are:

- Thermometers (→ Fig. 7, nos. 1 and 3):  
The built-in thermometers display the temperatures of the solar return (blue) and flow (red).
- Pressure gauge (→ Fig. 7, no. 2):  
The pressure gauge displays the operating pressure.

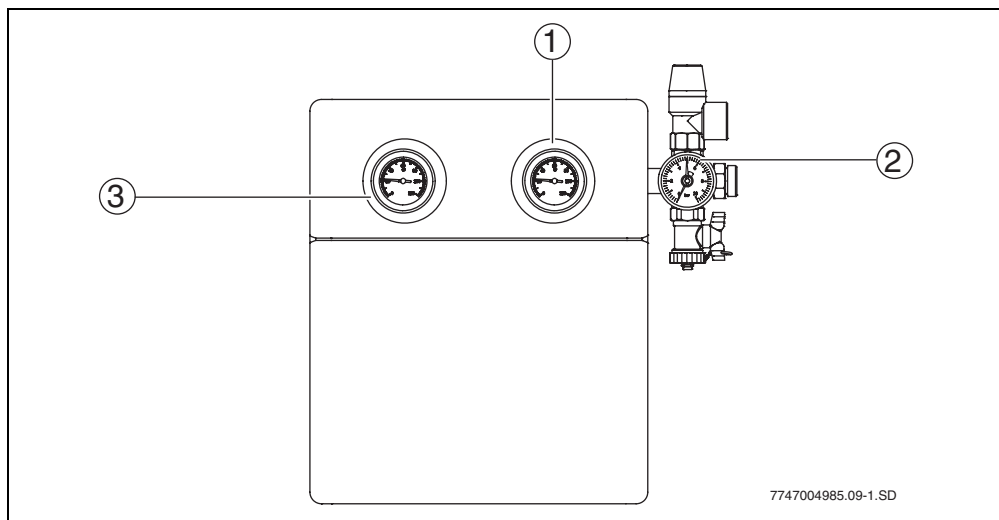

Fig. 7 Solar pump station

- 1 Display of temperature for solar return
- 2 Pressure gauge
- 3 Display of temperature for solar flow

## 5.2 ELEMENTS OF THE CONTROLLER

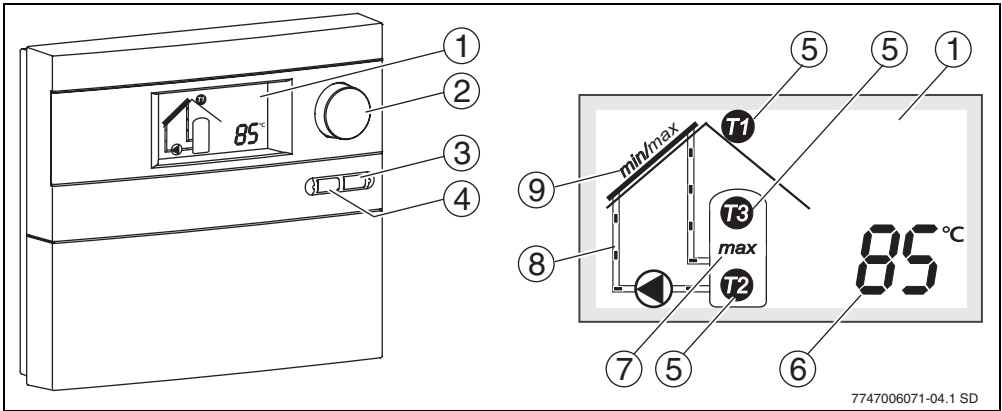

Fig. 8 Controller and display

- 1 Display
- 2 Rotary selector
- 3 Back button
- 4 Menu button
- 5 Symbol for temperature sensor
- 6 Displays of temperature values, operating hours etc.
- 7 Indicator for "maximum cylinder temperature reached"
- 8 Animated solar heating circuit
- 9 Indicator for "collector minimum or maximum temperature reached"



## 5.3 OPERATING MODES

### AUTOMATIC MODE

When the activation temperature difference between the two temperature sensors is reached, the connected pump starts running. The transport of the heat transfer fluid is shown by the animation on the display (→ Fig. 8, no. 8).

When the deactivation temperature difference is reached, the pump is switched off. To protect the pump, it is automatically activated for about three seconds approximately 24 hours after its last run.

### FUNCTION TEST, MANUAL MODE

This operating mode is only accessible in the main menu for qualified technicians.





## 5.4 DISPLAYING TEMPERATURE VALUES

In automatic mode, you can use the rotary selector  to display various system values (temperature values, operating hours, pump speed).



Temperature values are matched to their source by the location numbers on the pictogram.

**5.5 MAIN MENU (FOR QUALIFIED TECHNICIANS ONLY)**



The main menu of the controller is used for adjusting the control according to the characteristics of the solar heating system.

- ▶ To go to the main menu: press the  button.
- ▶ Use the rotary selector  to select the desired setting or function.
- ▶ To change the setting: press the rotary selector  and then turn.
- ▶ To save the setting: press the rotary selector  again.
- ▶ To leave the main menu: press the button .

If no entry is made for more than 60 seconds, the controller leaves the main menu.

Display	Function	Setting range [preset]	Set to
$\Delta T$ on	<p><b>Activation temperature difference</b></p> <p>When the set activation temperature difference (<math>\Delta T</math>) has been reached between the cylinder and collector array, the pump starts running. When the temperature difference falls to half of the set value, the pump switches off.</p>	7-20 K <b>[8 K]</b>	
max	<p><b>Maximum cylinder temperature</b></p> <p>When the temperature on the cylinder temperature sensor reaches the maximum cylinder temperature, the pump is switched off. "Max" flashes on the display and the temperature from the cylinder temperature sensor is displayed.</p>	20-90 °C <b>[60 °C]</b>	
	<p><b>Speed regulation</b></p> <p>This function increases the efficiency of the solar heating system. The system attempts to regulate the temperature difference between temperature sensors T1 and T2 to the value of the activation temperature difference.</p> <p>We recommend leaving this setting activated.</p>	on/off <b>[on]</b>	
	<p><b>Minimum speed for speed regulation</b></p> <p>This function defines the minimum pump speed, allowing the speed regulation to be adjusted to suit the design of the particular solar heating system.</p> <p>Never adjust the value below 50 % to avoid damaging the pump.</p>	30-100 % <b>[50 %]</b>	

Tab. 4 Functions in the main menu

Display	Function	Setting range [preset]	Set to
<i>min / max</i>	<p><b>Maximum and minimum collector temperature</b></p> <p>When the maximum collector temperature is exceeded, the pump is switched off.</p> <p>If the collector temperature falls below the minimum (20 °C), the pump will not start even if all other activation conditions are met.</p>	100-140 °C <b>[120 °C]</b>	
	<p><b>Evacuated tube collector function</b></p> <p>To pump warm heat transfer fluid to the sensor, the pump will be activated for five seconds every 15 minutes when the collector temperature is 20 °C or higher.</p>	on/off <b>[off]</b>	
	<p><b>Water filled system function</b></p> <p>This function is intended solely for regions where the high temperatures mean that damage from freezing usually cannot occur. When the water filled system function is activated and the collector temperature falls below +5 °C, the pump is switched on. Warm cylinder water is then pumped through the collector. When the collector temperature reaches +7 °C, the pump is switched off.</p> <p><b>Caution:</b> The water filled system function does not provide absolute protection from damage caused by freezing. The system may need to be operated with heat transfer fluid instead of water only!</p>	on/off <b>[off]</b>	
	<p><b>Information</b></p> <p>This function displays the software version.</p>		

Tab. 4 Functions in the main menu





Display	Function	Setting range [preset]	Set to
	<p><b>Manual mode “on”</b> Manual mode “on” triggers the pump for a maximum of 12 hours. The display alternates between “on” and the selected value. The transport of the heat transfer fluid is shown by the animation on the display (→Fig. 8, no. 8). Safety mechanisms remain activated, such as, for example, maximum collector temperature. After a maximum of 12 hours, the controller switches over to automatic mode.</p> <p><b>Manual mode “off”</b> The pump is deactivated and the heat transfer fluid remains stationary. The display alternates between “off” and the selected value.</p> <p><b>Manual mode “Auto”</b> When the activation temperature difference between the two temperature sensors is exceeded, the connected pump starts running. The transport of the heat transfer fluid is shown by the animation on the display (→Fig. 8, no. 8). When the deactivation temperature difference is reached, the pump is switched off.</p>	<p>on/off/Auto <b>[off]</b></p>	
<p><i>reset</i></p>	<p><b>Base settings</b> All functions and parameters are reset to their base settings (except for operating hours). After the reset, all parameters must be checked and may need to be re-adjusted.</p>		

Tab. 4 Functions in the main menu

	<p><b>WARNING:</b> Risk of scalding from domestic hot water temperatures over 60 °C!</p> <ul style="list-style-type: none"> <li>▶ To limit temperatures at the tap to a maximum of 60 °C install a blending valve.</li> </ul>
--	---

## 5.6 EXPERT MENU (FOR QUALIFIED TECHNICIANS ONLY)

For specialised systems, additional settings can be made in the expert menu.

- ▶ To go to the expert menu: press the  button and hold for about five seconds.
- ▶ Use the rotary selector  to select the desired setting or function P1 to P4.
- ▶ To change the setting: press the rotary selector  and then turn.
- ▶ To save the setting: press the rotary selector  again.
- ▶ To leave the expert menu: press the button .

Display	Function	Setting range [preset]	Set to
P1	<p><b>Minimum collector temperature</b></p> <p>If the collector temperature falls below the minimum, the pump will not start even if all other activation conditions are met.</p>	10-80 °C <b>[20 °C]</b>	
P2	<p><b>Deactivation temperature difference</b></p> <p>When the temperature difference falls below the set value, the pump switches off.</p> <p>The value can only be set in relation to the activation temperature difference set in the main menu (permanently set difference = 3 K, → Table 4, page 18).</p>	4-17 K <b>[4 K]</b>	
P3	<p><b>Activation temperature for water filled system function</b> (→ Table 4, page 18)</p> <p>When the water filled system function is activated and the collector temperature falls below the set value, the pump is switched on.</p> <p>The value can only be set in relation to the “Deactivation temperature for water filled system function” (permanently set difference = 2 K).</p>	4-8 °C <b>[5 °C]</b>	
P4	<p><b>Deactivation temperature for water filled system function</b></p> <p>When the water filled system function is activated and the collector temperature falls below the set value, the pump is switched on.</p> <p>The value can only be set in relation to the “Activation temperature for water filled system function” (permanently set difference = 2 K).</p>	6-10 °C <b>[7 °C]</b>	

Tab. 5 Functions in the expert menu

## 6 COMMISSIONING (FOR QUALIFIED TECHNICIANS ONLY)



**WARNING:** Pump damage from dry running.

- ▶ Make sure that the solar heating circuit is filled with heat transfer fluid (→ installation and maintenance instructions for solar pump station).

- ▶ When commissioning the solar heating system, read and keep in mind the technical documents for the solar pump station, the collectors and the cylinder.
- ▶ Only put the solar heating system into operation when all pumps and valves are in proper working order.



**WARNING:** System damage when commissioning due to frozen water or vaporisation in the solar heating circuit

- ▶ Shield the collectors from direct sunlight during commissioning.
- ▶ Do not commission the solar heating system in the event of frost.

Together with the solar pump station, observe the following steps:

- ▶ Check that the system is free of air.
- ▶ Check and adjust the flow rate.
- ▶ Enter the controller settings in the commissioning and maintenance report (→ Installation and maintenance instructions for the solar pump station).



**WARNING:** System damage due to incorrectly set operating mode.

To prevent undesired starting of the pump when the power supply is connected, the controller has been factory-set to manual mode “off”.





- ▶ For normal operation, set the controller to “Auto” (→ section 5.5, page 18).

# 7 FAULT FINDING

## 7.1 FAULTS WITH DISPLAY INDICATIONS

In the event of a fault, the display flashes red. The display also shows symbols indicating the type of fault.

- **For the user:** When a fault occurs, contact a qualified technician.

Display	Type of fault	Effect	Possible causes	Remedy
	<b>Sensor failure (temperature sensor for collector or cylinder)</b>			
	<b>Pump is switched off.</b>	Temperature sensor not connected or incorrectly connected.	Temperature sensor or sensor cable is faulty.	Check the sensor connection. Check the temperature sensor for damage or incorrect installation position.  Replace the temperature sensor. Check the sensor cable.
	<b>Collector temperature sensor short-circuit</b>			
	<b>Pump is switched off.</b>	Temperature sensor or sensor cable is faulty.		Replace the temperature sensor. Check the sensor cable.
	<b>Temperature difference between temperature sensors T1 and T2 is too great</b>			
	<b>No flow of fluid.</b>	Air in the system. Pump is jammed. Valves or shut-offs are closed. Blocked line.		Vent the system. Check the pump. Check valves and shut-offs.  Check line.
	<b>Collector connections mixed up</b>			
		The collector connections (return, flow) may be mixed up.		Check the flow and return pipes.

Tab. 6 Possible faults with display indications

Sensor faults are no longer displayed once the cause is eliminated.

- For other faults: press the  button to switch off the fault display.

**7.2 FAULTS WITHOUT DISPLAY INDICATIONS**

<b>Type of fault</b>		
<b>Effect</b>	<b>Possible causes</b>	<b>Remedy</b>
<b>Display is blank. Pump not running although activation conditions are met.</b>		
The cylinder is not being supplied by the solar heating system.	No power supply; fuse or power cable faulty.	Check fuse and replace if necessary. Ask an electrician to check the electrical system.
<b>Pump not running although activation conditions are met.</b>		
The cylinder is not being supplied by the solar heating system.	Pump switched off in “manual mode”.	Use the “manual mode” function to switch to automatic.
	Cylinder temperature “T2” is close to or above the set maximum cylinder temperature.	When the temperature drops 3 K below the maximum cylinder temperature, the pump will switch on.
	Collector temperature “T1” is close to or above the set maximum collector temperature.	When the temperature drops 5 K below the maximum collector temperature, the pump will switch on.
<b>Pump not running although the circuit animation is showing on the display.</b>		
The cylinder is not being supplied by the solar heating system.	The line to the pump is interrupted or not connected.	Check the line.
	Pump is faulty.	Check the pump and replace if necessary.
<b>Circuit animation running on the display; pump “humming”.</b>		
The cylinder is not being supplied by the solar heating system.	The pump is stuck due to a mechanical blockage.	Unscrew and remove the slotted screw on the pump head and use a screwdriver to release the pump shaft. Do NOT strike the pump shaft with the screwdriver.
<b>Temperature sensor is displaying an incorrect value.</b>		
Pump is being activated/deactivated too early / too late.	Temperature sensor not correctly installed. Incorrect temperature sensor installed.	Check position, installation and type of sensor; add heat insulation if necessary.

*Tab. 7 Possible faults without display indications*



<b>Type of fault</b>		
<b>Effect</b>	<b>Possible causes</b>	<b>Remedy</b>
<b>Potable water is too hot.</b>		
Risk of scalding	Cylinder temperature limit and mixing valve are set too high.	Set the cylinder temperature limit and blending valve to a lower setting.
<b>Potable water too cold (or volume of warm potable water is too low).</b>		
	Domestic hot water thermostat on heating appliance, on heating controller or on mixing valve is set too low.	Set the temperature as instructed in the applicable operating manual (max. 60 °C).

*Tab. 7 Possible faults without display indications*

## 8 NOTES FOR THE USER

### 8.1 WHY IS REGULAR MAINTENANCE IMPORTANT?

Your solar heating system for potable water heating, or for potable water heating and domestic heating back-up, is nearly maintenance-free.

Nonetheless, we recommend that you have your system maintained every two years by your local qualified technician. In this way you can ensure smooth and efficient operation and early detection and elimination of any possible damage.

### 8.2 IMPORTANT NOTES ON HEAT TRANSFER FLUIDS



**WARNING:** Risk of injury through contact with heat transfer fluid (water / propylene glycol mixture)

- ▶ If heat transfer fluid comes into contact with eyes: holding eyelids wide open, thoroughly wash eyes with running water.
- ▶ Keep heat transfer fluid out of reach of children.

The heat transfer fluid is biodegradable.

Your technician has been instructed, during commissioning of the solar heating system, to ensure the heat transfer fluid is protected from freezing, down to at least -30 °C.

### 8.3 CHECKING THE SOLAR HEATING SYSTEM

You can contribute to the smooth functioning of your solar heating system by doing the following:

- Checking the temperature difference between flow and return and between the collector temperature and cylinder temperature twice a year
- Checking the operating pressure for solar pump stations
- Checking the heat quantity (if a calorimeter has been installed) and/or the operating hours.



Enter the values in the log on page 28 (which may also be copied). The completed log can help qualified technicians when checking your solar heating system and performing maintenance.

---

## 8.4 CHECKING OPERATING PRESSURE, WITH POSSIBLE RE-ADJUSTMENT



Pressure fluctuations in the solar heating circuit due to temperature changes are normal and do not lead to faults in the solar heating system.

- ▶ Check the operating pressure on the pressure gauge (→ Fig. 7) when the system is cold (about 20 °C).

### IF PRESSURE DROPS

A pressure drop can be caused by the following:

- There is a leak in the solar heating circuit.
- An automatic air vent has expelled air or vapour.

If the pressure of the solar heating system has dropped:

- ▶ Check whether heat transfer fluid has collected in the storage vessel under the solar pump station.
- ▶ Call in a professional technician if the operating pressure has dropped 0.5 bar below the value entered in the commissioning report (→ Installation and maintenance instructions for the solar pump station).

## 8.5 CLEANING THE COLLECTORS



**DANGER:** Risk of death by falling from roof

- ▶ Inspection, maintenance and cleaning work on the roof must only be carried out by qualified technicians.

Due to the self-cleaning effect when rain falls, the collectors do not need cleaning.

## 9 SYSTEM DETAILS

System operated by:	Date commissioned:
Number of collectors:	Collector type:
Cylinder type:	Inclination of roof:
Facing direction:	Solar pump station:

Date	Thermometers on solar pump station		Temperatures displayed on controller		Pressure gauge on solar pump station		Operating hours and/or heat quantity in kWh	Weather conditions 1=clear sky 2=partly cloudy 3=very cloudy 4=overcast
	Solar flow, red, in °C	Solar return, blue, in °C	Collector (°C)	Cylinder bottom (°C)	Operating pressure in bar	Operating pressure in bar		

Tab. 8 Log for solar heating system values (can be copied)

---

# NOTES

---

# NOTES

---

# NOTES



6720644596

**WORCESTER, BOSCH GROUP:**

TECHNICAL SUPPORT: 0844 892 4010

APPOINTMENTS: 0844 892 3000

SPARES: 01905 752571

LITERATURE: 0844 892 9800

TRAINING: 01905 752526

SALES: 01905 752640

WEBSITE: [worcester-bosch.co.uk](http://worcester-bosch.co.uk)

Worcester, Bosch Group  
Cotswold Way, Warndon, Worcester WR4 9SW.  
Tel. 0844 892 9900

Worcester, Bosch Group is a brand name of  
Bosch Thermotechnology Ltd.  
[worcester-bosch.co.uk](http://worcester-bosch.co.uk)

6 720 644 596



**WORCESTER**  
Bosch Group