

GLL SKGLA1.5 WR

GLACIER Sink Range Gallery Glacier Easyfit Sink 1.5 Bowl White Glass Right Drainer



Specification

Main Construction Material:	Glass & Stainless Steel
Number of Tap Holes:	1
Product Finish:	White and Stainless Steel
Sink Type:	1.5 Bowl
Connection Inlet:	½" BSP Flexi Tails
Connection Outlet:	G 1½"
Product Orientation:	Right Drainer

Features:

- Easy installation: pre-fitted with Easyfit tap base, flexible inlet pipes and isolators
- Everything you need: strainer waste, overflow, pipework and fixings included
- Made to last: 8mm toughened glass with 304 grade 18/8 stainless steel base
- Includes cutting-hole template
- 25 year guarantee (Easyfit base 5 years)

Product Certifications:



For more products, visit our website:
<http://www.bristan.com>



Dimensions (measurements in mm)

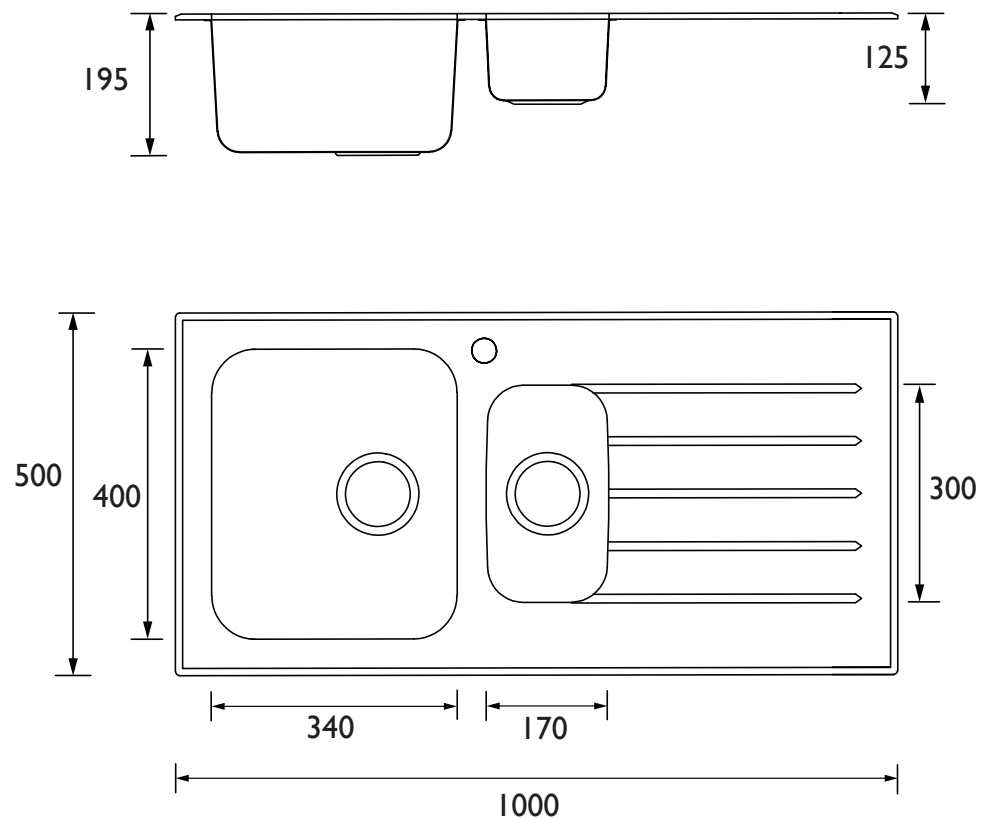

Minimum Cabinet Width: 600mm

TECHNICAL
DATA
SHEET



Kitchen Sinks



Tap



Waste Kit

BRISTAN
TAPS & SHOWERS D1