

GLL RAPSNK4 C

GALLERY Tap Range Gallery Rapid Boiling 4-in-1 Sink Mixer Chrome



Features:

- The latest in kitchen innovation, combining hot, cold, boiling and filtered water in one contemporary styled design. With a unique touch control illuminated handle, this is a perfect addition to any kitchen.
- Everything you need: tap, tails, tank, pressure reducing valve and filter included
- Safety: Touch control handle requires a few seconds contact to dispense boiling water, avoiding accidental activation
- Safe to touch spout: Boiling water is stored in the tank not in the tap reducing the risk of scalding
- Quality: Hard wearing, flawless finish that lasts

Product Certifications:



For more products, visit our website:
<http://www.bristan.com>



Specification

Product Type:	Kitchen Taps
Main Construction Material:	Brass; ABS
Mount Type:	Deck
Handle Type:	1 Lever Handle, 1 LED Push-button Handle
Connection Inlet:	1/2" BSP Flexible Tails
Number of Tap Holes:	1
Tank Capacity:	3 litres
Temperature Settings:	4 Settings; Min: 80°C Max: 98°C
Plumbing System Requirements:	Suitable for high pressure systems only
Working Pressure Range:	Min: 1.5 bar Max: 3 bar
Maximum Hot Water Temperature: °C	65
Maximum Static Pressure: (bar)	3
Flow Type:	Dual
Isolation Included:	No
Power Rating:	1.83 - 2.0kW
Electrical Supply Requirements:	230-240 AC, 50 Hz, IPX3 Protection

Dimensions (measurements in mm)

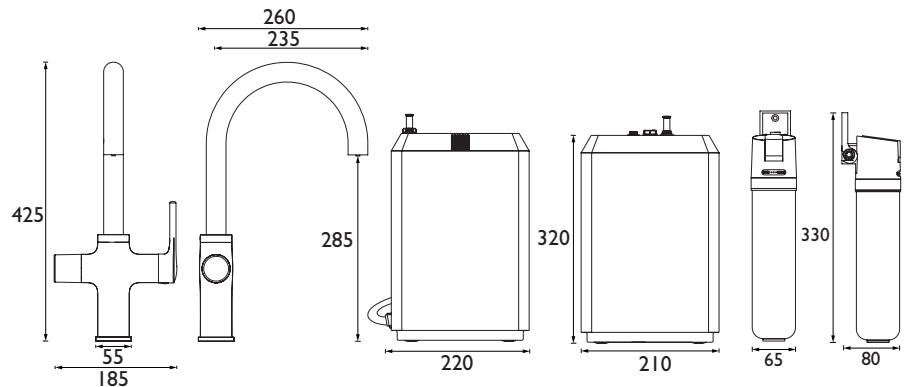

Flow Rates (l/min)

System Pressure (bar)	1.5	2	3
GLL RAPSNK4 C (Mixed)	10	11.7	14.3
GLL RAPSNK4 C (Boiling Water)	2	2	2
GLL RAPSNK4 C (Filtered Water)	2	2	2

TECHNICAL
DATA
SHEET



BRISTAN
TAPS & SHOWERS

D1