

# Installation Instructions

4 Hole Single Lever Bath Shower Mixer

# Installation Instructions

## Parts Supplied

Please read these instructions carefully before starting installation and keep for future reference. Remove all packaging and check the product for missing parts or damage before starting installation. Any alterations made to this product and fittings may infringe water regulations and will invalidate the guarantee. The installation must comply with all Local/National Water Supply Authority Regulations/ Byelaws and Building and Plumbing (UK:BS6700) Regulations. We strongly recommend that you use a qualified and registered plumber.

## General Installation

These fittings are mixing devices and therefore water supplies must be reasonably balanced. Where connections are made to the mains cold water supply, WRC approved single check valves must be fitted to both hot and cold inlets. This is a stated requirement of Water Supply (Water Fittings) Regulations 1999 Schedule 2, Section 6 G15.13.2 Before making any inlet pipe connections, all supply pipes **MUST** be thoroughly flushed to remove debris. Failure to do so could result in damage or low flow from the mixer unit. Water Supply (Water Fittings) Regulations 1999 Schedule 2 Section 4 G13.1 The fitting of isolating valves to the inlet feeds is advised for ease of maintenance. Please take great care when installing this mixer not to damage its surface.

## Care of The Taps

Our products are finished to the highest standard and due care needs to be taken to ensure their looks are retained. We recommend cleaning all products with a soft damp cloth **ONLY** and advise strongly against the use of **ALL** cleaning products i.e. powders and liquids. If the above instructions are not followed this will invalidate your guarantee in the event of a problem occurring.

## Dimensions

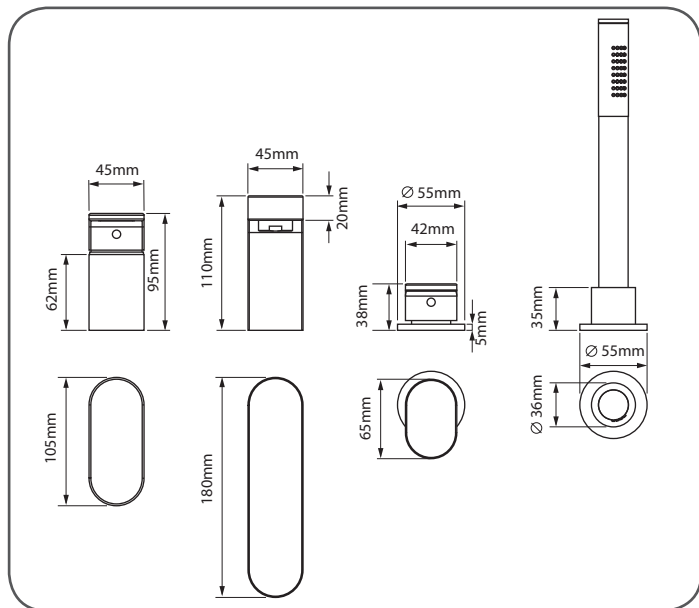

## Operating Pressure

Minimum operating pressure 3 bar

Maximum operating pressure 5 bar

## Installation - Tap

Before installing your new mixer, flush through the pipework to ensure removal of debris, turn off the water supply. Remove the nut and washer and push the valve down through the hole in the unit, slide the rubber washer and nut over the flexible pipes and outlet pipe and screw onto the valve. Tighten the nut to clamp the mixer to the unit.

**CAUTION: Do not over tighten the nut as this may damage the unit.**

Connect the water supply to the inlet pipes. The hot water should be connected to the left hand pipe. Connect the back outlet pipe to the diverter valve using a flexible pipe.

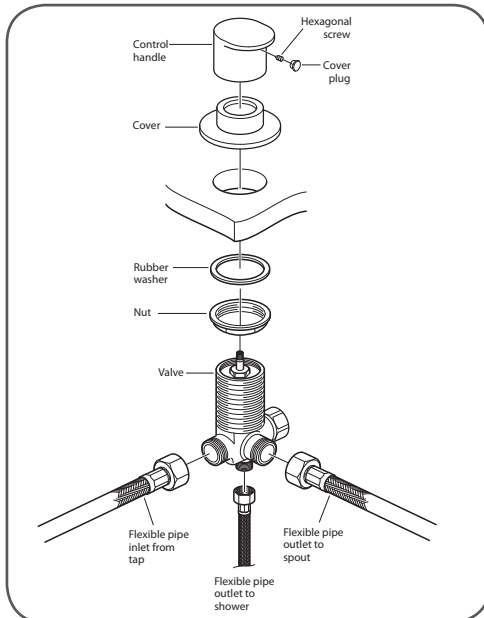
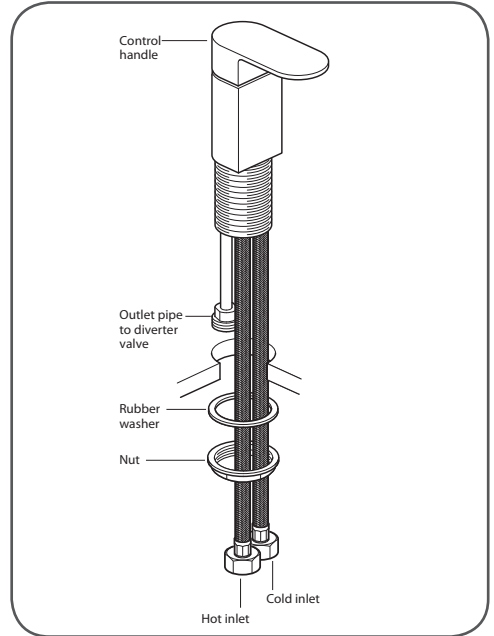

## Installation - Diverter Valve

Screw the nut onto the valve body followed by a rubber washer. Push the valve up through the hole in the unit. Screw on the cover, carefully push the control handle onto the splines of the valve and secure using the hexagonal screw, replace the screw cover. From the underside tighten the nut to secure the valve in place.

**CAUTION:** Do not over tighten the nuts as this might damage the unit. Connect the valve to the tap, shower and spout using the flexible connectors.

Due to our commitment to continuous product development we reserve the right to alter specifications without notice. Products are guaranteed against manufacturing defects for the first purchaser only and the guarantee is non-transferable. Our liability under any guarantee expressed or implied is strictly limited to replacement of defective goods or a refund at our discretion and no consequential losses will be entertained. Proof of purchase will be required.