

Automatic Air Vent - 15mm

TR15AAV

Installation and Maintenance Instructions

Please leave this Manual for the User

To activate your product warranty please visit
www.intatec.co.uk
and click on Product Registration

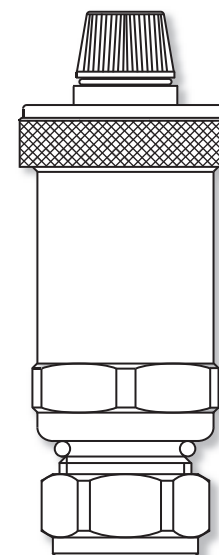

Intatec Ltd
Airfield Industrial Estate
Hixon
Staffordshire
ST18 0PF

Tel: **01889 272 180**
Fax: **01889 272 181**
email: **sales@intatec.co.uk**
web: **www.intatec.co.uk**

15-11-22

Intatec Ltd
Airfield Industrial Estate
Hixon
Staffordshire
ST18 0PF

Tel: **01889 272 180**
Fax: **01889 272 181**
email: **sales@intatec.co.uk**
web: **www.intatec.co.uk**

Introduction

The Trade Tec automatic air vent is designed to automatically discharge the air collected at the highest points in a system and in the float chamber of the air vent.

Automatic air vents optimise system efficiency by continuously discharging air.

It is recommended, especially in hard water areas, that a water softener such as the ActivFlo or ActivFlo lite be fitted to reduce the risk of calcium deposits forming.

Technical Specification

Maximum peak pressure:	10 bar
Maximum operating pressure:	6 bar
Maximum peak temperature:	110 °C
Temperature range:	0 to 100 °C
Medium:	Water / Glycol up to 50%
Compression connection:	15mm

Dimensions

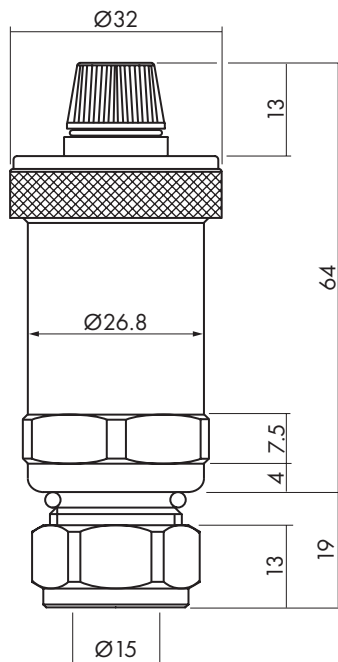

Components

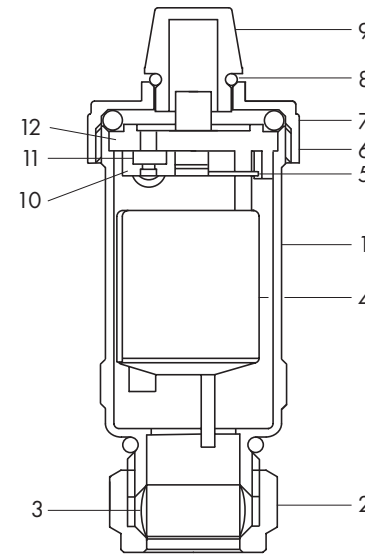

Item	Component	Material
1	Body	Brass
2	Compression nut	Brass
3	Olive	Brass
4	Float	Polymer
5	Bracket	Stainless steel
6	Bonnet	Brass
7	'O' ring	EPDM
8	Washer	EPDM
9	Cap	POM
10	Holder	POM
11	Washer	EPDM
12	Cover	POM

Installation

The compression joint complies with BS EN 1254-2 and should be used with copper tube to BS EN 2871, R250 (half hard).

The automatic air vent should be installed at the top of a riser or at the highest part of a system where air may collect.

De-burr the end of the copper tube before fitting the compression nut and olive.

To make the compression joint use 2 suitable sized spanners or adjustable spanners use the hexagon on the body and compression nut to tighten the joint.

The automatic air vent can be screwed into a female threaded fitting using the 'O' ring to achieve a seal.

Filling the System

During system filling the automatic air vent should be open to allow air in the pipework to escape.

During filling the cap (9) can be removed to speed up air release provided that a small amount of water spillage will not cause serious damage.

As the system approaches full the water should enter the float chamber and the air vent should close.

Refit the cap (9).

Operation

During normal operation with cap (9) should be open slightly to allow air to be automatically released.