

inta

Flow Balancing Valve

INFBV28 & INFBV2850

Installation and Maintenance Instructions

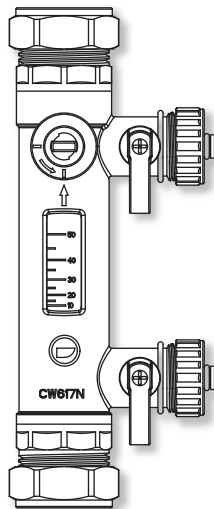

inta

Intatec Ltd
Airfield Industrial Estate
Hixon
Staffordshire
ST18 0PF

In this procedure document we have endeavoured to make the information as accurate as possible.

We cannot accept any responsibility should it be found that in any respect the information is inaccurate or incomplete or becomes so as a result of further developments or otherwise.

Tel: **01889 272 180**
Fax: **01889 272 181**
email: **sales@intatec.co.uk**
web: **www.intatec.co.uk**

Introduction

The Inta flow balancing valves with flow indicator include fill and flush connections, these are used to accurately adjust the flow rate of the heating medium supplying the terminal emitters of a system.

The valves can be manually adjusted to the required flow rate without the aid of differential pressure gauges and calibration graphs.

The clear window allows for the flow rate to be read easily during valve adjustment and in normal operation.

The fill and flush connections can be used to fill the system. They can also be used to flush the system, removing debris which could impair the performance of the valve and other components.

Valves must be selected to suit the required flow rate.

These instructions cover the installation, operation and maintenance. Please read the enclosed instructions before commencing the installation of this product, please note;

We recommend that the installation of any Inta product is carried out by an approved installer.

It is recommended, especially in hard water areas, that a water softener such as the ActivFlo or ActivFlo lite be fitted to reduce the risk of calcium deposits forming.

Products

| | |
|--|-----------|
| Flow balancing valve with flow indicator and fill & flush - 4 to 40 l/m | INFBV28 |
| Flow balancing valve with flow indicator and fill & flush - 10 to 50 l/m | INFBV2850 |

Technical Specification

| | |
|--|--------|
| Maximum operating pressure: | 10 bar |
| Maximum operating temperature: | 110 °C |
| Minimum operating temperature: | -20 °C |
| Medium: | Water |
| Maximum glycol solution: | 50% |
| Compression connections to BS EN 1254-2: | 28mm |

Dimensions

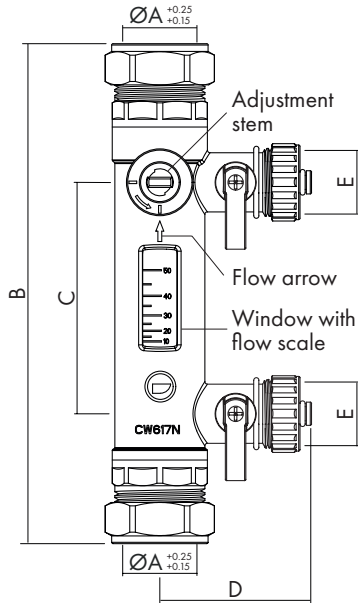

| | ØA | B | C | D | E |
|-----------|-------------|-------|----|------|-----------------|
| INFBV28 | 28 | 184.5 | 80 | 53.5 | G $\frac{3}{4}$ |
| INFBV2850 | 28 | 195 | 90 | 54.5 | G $\frac{3}{4}$ |

Installation

The system must be thoroughly flushed to remove any debris, metal particles and any other contaminants.

As in all hydraulic circuits it is important to pay attention to the cleanliness of the entire system. For optimum performance any air in the flowing medium must be removed.

To ensure flow measuring accuracy the balancing valve with flow meter must be installed in straight pipe with a minimum length upstream of five pipe diameters and ideally ten pipe diameters if space permits.

The balancing valves must be installed so that the flow direction of the medium coincides with integral flow direction arrow on the body.

Ensure there is easy access to the balancing valve control stem used to regulate the flow rate and to the flow meter to enable the balancing valve to be set.

Ensure there is also easy access to fill and flush connections and to their isolating valves.

The balancing valves may be installed in both horizontal and vertical pipes with the flow in any direction provided that it coincides with the flow direction arrow on the valve body.

Filling the System

The upper connection can be used to fill the system.

Before commencing open all manual air vents to allow air to escape.

Remove the blanking cap and replace with a hose connector and hose.

Open the adjustment stem and slowly open the upper ball isolating valve.

Allow the system to fill until water escapes from the air vents to indicate that the system is full.

Close the upper ball valve, turn on the pump and allow the water to circulate for several minutes before checking if more air has collected and needs to be removed and the system topped up.

Remove the hose, and refit the blanking cap.

Close the adjustment stem ready for flow rate adjustment.

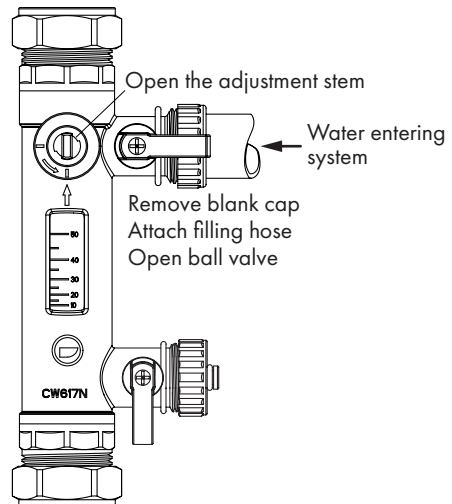

Flushing the System

Both connections are used to flush the system.

The system should be full of water.

Remove the blanking caps and replace with hose connectors and hoses.

Open the adjustment stem and slowly open the upper ball and then lower isolating valves.

Allow clean water to circuit around the system until the water leaving the system is clear and free from debris.

Close the upper and lower ball valves, remove the hoses, and refit the blanking caps.

Close the adjustment stem ready for flow rate adjustment.

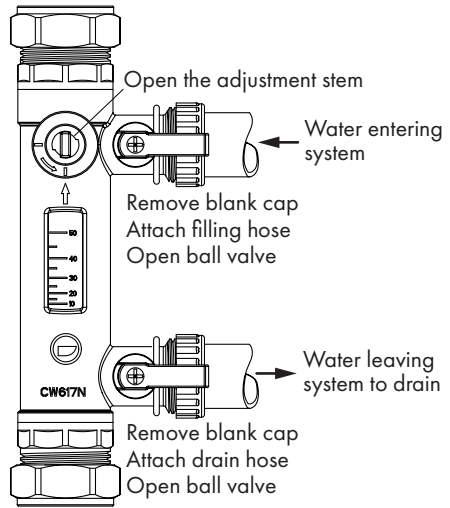

Flowrate Adjustment

Ensure that the balancing valve selected is suitable for the designed flow rate of the circuit.

Start with the valve in the closed position.

With the system full, the pump running and the air removed use a suitably sized key or adjustable wrench to slowly open the balancing valve.

The bottom of the float indicates the flow rate.

The float/indicator, which is controlled by the spring, becomes visible in the window of the flow meter and lines up with the marks on the scale.

Once the designed flow rate is indicated, stop opening the balancing valve and allow the flow to settle before moving onto the next balancing valve.

Glycol Mixture

Although the density of glycol mixtures is different from that of water, for glycol percentages up to 50%, the accuracy of the balancing valve should not deviate anymore than 10% from the true value.

Notes:

Notes:

inta

Please leave this Manual for the User

To activate your product warranty please visit

www.intatec.co.uk

and click on Product Registration

inta

Intatec Ltd

Airfield Industrial Estate

Hixon

Staffordshire

ST18 0PF

Tel: **01889 272 180**

Fax: **01889 272 181**

email: **sales@intatec.co.uk**

web: **www.intatec.co.uk**

E & O.E

© Intatec Ltd 2023

17-02-23